

Series 228PV

**Plastic Tee Type
Wireless Flow Sensor**

**Installation &
Operation Manual**



TABLE OF CONTENTS

Introduction2
 Installation2
 Theory of Operation.5
 Programming Software Installation5
 Wireless Receiver Programming6
 Wireless Sensor Programming7
 Specifications8

INTRODUCTION

The Series 228PV wireless flow sensor system includes the flow sensor mounted in a tee, radio frequency (RF) transmitter complete with mounting kit, and RF receiver / pulse transmitter. This system eliminates the need for expensive signal wires from the sensor output. The battery powered flow sensor performs flow measurement and scaling and then transmits a total flow value to the RF transmitter. The transmitter sends an RF signal approximately every four seconds that the RF receiver detects. The RF receiver compares the previous flow total with the most recent flow total to generate a pulse output. Using PC software, which is part of the software installation kit, the pulse output can be scaled to represent the desired volume unit and number of output pulses per unit volume that best fits the application. Pulse width can also be adjusted to meet the requirements of an interfacing control system or monitor.

Optional equipment offered with the 228PV wireless system include two types of antenna kits and a software installation kit complete with software and programming cables. Additionally, DIN rail mounting clips are available. These accessories can be ordered by specifying the appropriate model number from the Sensor System Matrix.

Series 228PV Wireless Flow Sensor

The four-bladed impeller design is rugged, non-fouling and does not require custom calibration. Coupled with the proprietary patented digital detection circuit, the sensor measures flow rate from 1 foot per second (fps) to over 20 fps regardless of conductivity or turbidity of the liquid. The flow sensor generates a frequency which is proportional to flow rate. An integral micro controller measures the impeller frequency and uses the appropriate K factor and offset values to compute the flow rate. By means of integration, the volume total is calculated. The output signal to the RF transmitter is a scaled output pulse. An internal lithium battery provides power for the flow sensor and is encapsulated to ensure moisture resistance.

Wireless Badger® ORION RF Transmitter

The Badger ORION® transmitter operates in the 902-928 MHz frequency band at a power level which requires no F.C.C. licensing. The transmitter is powered using an internal lithium battery and is encapsulated to ensure moisture resistance. It is factory programmed and requires no configuration.

Wireless Badger ORION RF Receiver

The Badger ORION receiver is powered using an external alternating current (AC) or direct current (DC) power supply. The wireless receiver receives the scaled total from the transmitter. Further scaling and unit conversion can be programmed into the receiver. The optically coupled scaled pulse output emulates a dry contact closure to ensure interfacing into various types of controller inputs.

Example: 2 28 PV xx 0 W - 1 2 3 1 X X X	
STYLE	Tee Mounted 28
MATERIAL	PVC PV
SIZE	1.5" 15 2" 20 3" 30 4" 40
ELECTRONICS HOUSING	Acetal Housing w/ Fortron Polyphenylene Tip 0
ELECTRONICS	Wireless Transmitter and Receiver W
O-RING	EPDM 1
SHAFT	Tungsten Carbide 2
IMPELLER	420 Stainless Steel 3
BEARING	UHMWPE (ultra-high molecular weight polyethylene) 1
ANTENNA	No Option 0 Low Profile Type A355LP Antenna 1 Whip Type A355 Antenna 2
SOFTWARE INSTALLATION KIT	No Option 0 A301W-20 Cable, IR Cable, Software 1
MOUNTING	No Option 0 DIN Rail Mounting Clips 1

**Wireless Series 228PV Flow Sensor System Matrix
(1½" to 4")**

INSTALLATION

General

As with all flow measuring devices accuracy is highly dependent on proper location of the sensor in the piping system. Irregular flow velocity profiles caused by valves, fittings, pipe bends, etc. can lead to inaccurate overall flow rate indications even though local flow velocity measurement may be accurate. A sensor located in the pipe where it can be affected by air bubbles, floating debris, or sediment may not achieve full accuracy and could be damaged. Badger Meter flow sensors are designed to operate reliably under adverse conditions, but the following recommendations should be followed to ensure maximum system accuracy:

- 1) Choose a location along the pipe with a length equivalent to 10 pipe diameters upstream and 5 pipe diameters downstream of the sensor which are free of flow disturbances. Pipe bends, valves, other fittings, pipe enlargements, and reductions should not be present in this length of pipe.
- 2) When the sensor is installed in horizontal piping, the preferred sensor orientation is vertical, on top of the pipe. If trapped air or debris could potentially interfere with sensor operation the sensor can be installed as much as 45 degrees from the vertical. Please note that when the sensor is installed "off the vertical", impeller friction increases which may affect performance at low flow rates and increase wear. The sensor should never be located at the bottom of the pipe, as sediment may collect there. When the sensor is installed in vertical piping, it can be installed at any circumferential position. Rising flow is preferred to reduce the effects of trapped air.

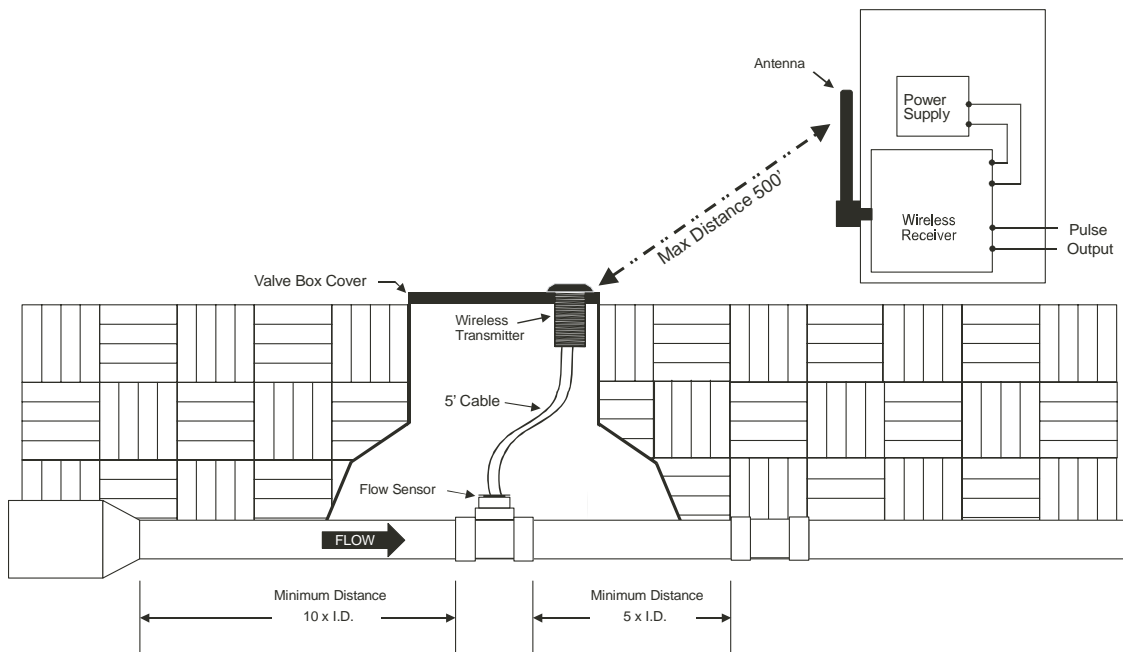

Typical Wireless Flow Sensor Installation

Wireless Series 228PV Plastic Tee Sensor Mechanical Installation

- 1) Note intended direction of flow as indicated by arrows on the tee. There must be free, unrestricted pipe for at least 10 diameters upstream and 5 diameters downstream of the tee.

Note: Cable length between sensor and wireless transmitter is 5 feet. Plan for cover removal if inserting into a valve box.
- 2) Remove the clevis pin and remove the sensor from the tee.
- 3) Properly clean the pipe ends and tee sockets.
- 4) For 228PV, solvent cement the pipe to the tee.
- 5) Reinstall sensor in tee as follows:
 - a) Align small diameter blind hole on top surface of sensor with tip of flow arrow on tee.
 - b) Carefully press sensor straight into tee.
 - c) Install clevis pin through tee and sensor.
 - d) Install cotter ring.
- 6) Remove wireless transmitter cap from wireless transmitter body by unscrewing it in the counterclockwise direction.
- 7) Insert wireless transmitter body through a minimum 1 5/8" hole in valve box cover. (maximum hole size 2 1/2")
- 8) Screw wireless transmitter cap hand tight to wireless transmitter body then screw nut against the inside of the valve box cover so cap is tight.

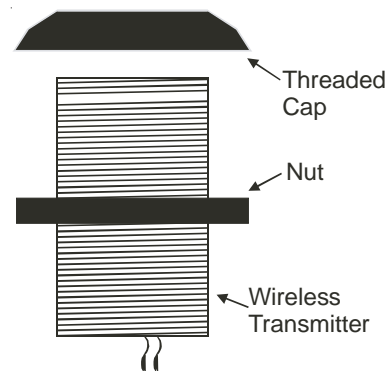

Figure 1: Badger ORION Wireless Transmitter with Threaded Cap Removed

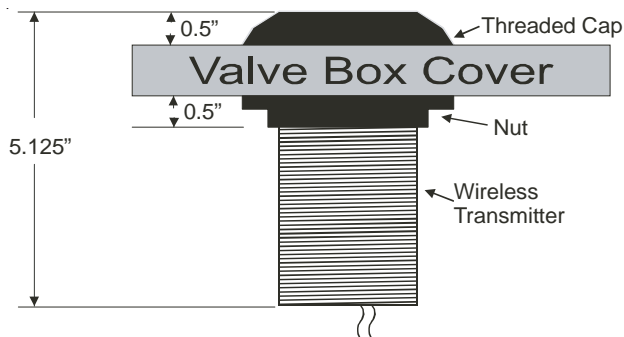

Figure 2: Badger ORION Wireless Transmitter Installed in Valve Box Cover

Badger® ORION® Wireless Receiver Mechanical Installation

The wireless receiver may be surface mounted onto a panel or attached to DIN rails using adapter clips.

Location

Although the wireless receiver is encapsulated, all wiring connections are made to exposed terminals. The unit should be protected from weather and moisture in accordance with electrical codes and standard trade practices. In any mounting arrangement, the primary concerns are ease of wiring and attachment of the programming cable.

The unit generates very little heat so no consideration needs to be given to cooling or ventilation.

The ideal receiver location would be within a clear line-of-sight of the flow sensor. However, this is rarely possible, with the line-of-sight hindered by obstructions such as trees and vegetation, buildings and other structures, vehicles, and uneven terrain.

Surface Mount Installation

The wireless receiver may be mounted to the surface of any panel using double sided adhesive tape or by attaching fasteners through the holes in the mounting flanges of the unit.

DIN Rail Mounting

Optional clips snap onto the mounting flanges allowing the wireless receiver to be attached to DIN 15, 32, 35 mm DIN rail systems.

Antenna Installation

The Badger® ORION® RF receiver requires an external antenna to communicate with the RF transmitter. The antenna is typically mounted directly to a customer supplied enclosure which houses the RF receiver. The antenna may also be installed remotely from the enclosure to be within clear line-of-sight of the RF transmitter.

Antenna kits are an optional accessory and can be ordered by specifying the appropriate model number from the Sensor Selection Matrix. Badger Meter offers two different antenna kits: the A355LP low profile antenna kit and the A355 whip style antenna kit.

The A355LP kit includes a low profile antenna and antenna cable with mounting hardware. The more durable, low profile antenna is 2.3" in height and designed to operate in a frequency bandwidth of 902 – 928 MHz with a gain of 3 dB.

The A355 kit includes a whip style antenna, antenna cable, mounting hardware, and 90 degree BNC adaptor. The half-wave, whip style antenna is 8" in height and designed to operate in a frequency band of 902 – 970 MHz with a gain of 2.5 dB.

Both kits are supplied with RG58C/U type antenna cable.

Please refer to Figures 4 and 5 for suggested antenna installation, mounting hole sizes, and component part numbers. Please note that antenna cable lengths of more than three feet will negatively affect signal strength. Antennas operate more effectively when well grounded (with a 3" diameter ground plane); grounding washers, included in both installation kits, are strongly recommended.

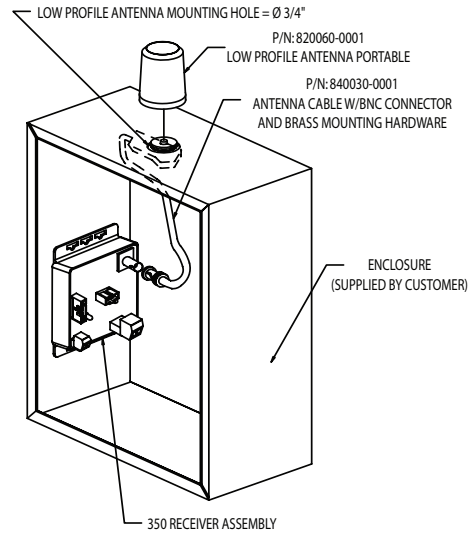

Figure 4: A355LP Antenna Kit

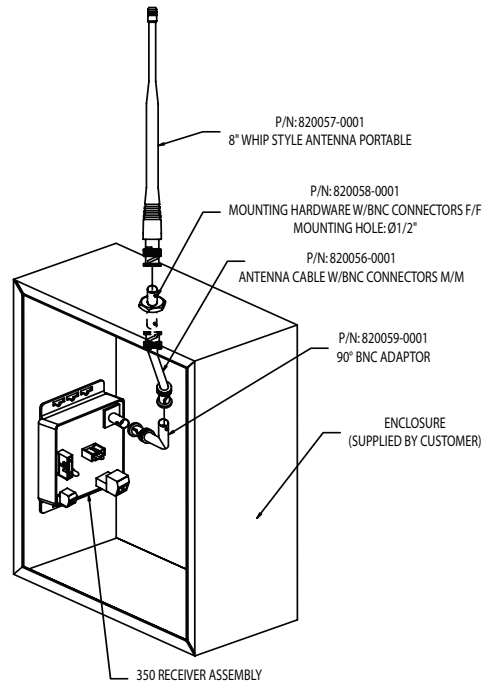

Figure 5: A355 Antenna Kit

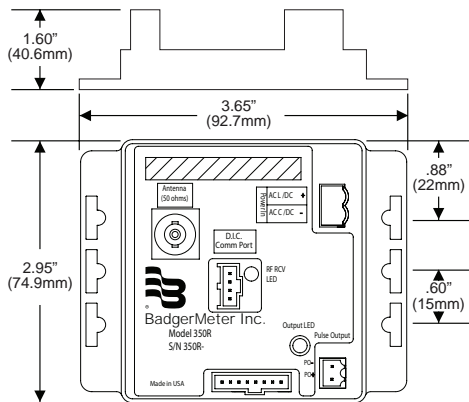
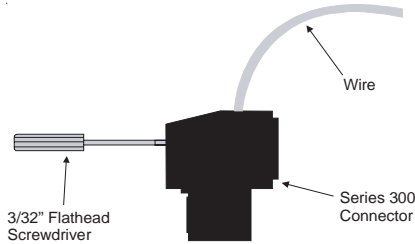

Figure 3: Badger ORION Wireless Receiver Dimensions

Badger® ORION® Wireless Receiver Electrical Installation
 Per standard wiring practices, the power must be off before making any wire connections. The terminal strips have removable plug-in connectors to make wiring easier.



Side View - Typical Series 300 Removable Connector Wiring

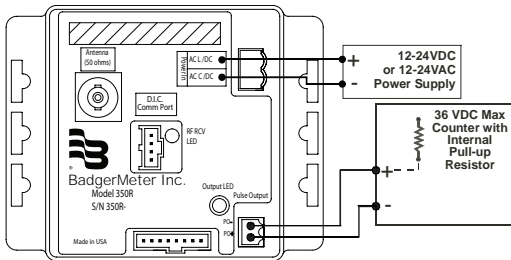

Figure 6: Sample Badger ORION Wireless Receiver Electrical Wiring

1. Refer to Figure 6 for terminal connections and wiring example.
2. Connect DC power supply positive (+) or AC Line to wireless receiver terminal marked AC L /DC (+).
3. Connect DC power supply negative (-) or AC Common to wireless receiver terminal marked AC C /DC (-).
4. Connect Pulse(+) of a pulse input device to wireless receiver terminal marked PO(+). Connect Pulse(-) of the input device to wireless receiver terminal marked PO(-).
5. Connect 50Ω (ohm) Antenna to BNC Antenna connector of wireless receiver.

THEORY OF OPERATION (SCALED PULSE VERSION)

The Badger ORION RF receiver can be located up to 500 feet away from the RF transmitter and must be powered with 12-24 VAC/VDC. A BNC connector is provided on the RF receiver to accept a 50 Ohm, half wave antenna.

There are two red LED's on the Badger ORION RF receiver. The "RF RCV" LED in the middle of the unit flashes each time it receives an updated total from the RF transmitter, approximately every four seconds. The "OUTPUT" LED flashes each time an output pulse is generated by the receiver.

After each update, the RF receiver compares this updated total with the last one received. The difference is the total volume in gallons which has passed through the sensor for the period in question. The RF receiver then generates a continuous burst of output pulses with a duty cycle of 50%. These pulses can be scaled using the DIC Com Port and Badger Meter software to represent the desired volume unit, number of volume units per pulse, and pulse width which best fit the application. Default values for these settings are gallons, 10 gallons per pulse, and 50 milliseconds, respectively.

Should a combination of volume units, volume units per pulse, and pulse width be selected such that the number of corresponding output pulses cannot be generated in the 4-5 second update window, the RF receiver will simply delay the next update until the pulse string has been completed.

Example:

Sensor Model:	228PV200W-1231-000
Line Size:	2"
Gallons per Integer Output from Transmitter:	1 (default)
Volume Unit Selected in Receiver:	liters
Volume Units per Pulse Output from Receiver:	10
Pulse Width:	50 milliseconds

If 10 gallons pass through the sensor in a given four second window, 10 integer values would be sent by the transmitter in the next update, representing a volume of 10 gallons. The receiver would, in turn, convert the 10 gallons into 37.8 liters and generate three output pulses, representing a volume of 30 liters. Because partial counts exist in both the sensor and receiver, the remaining 7.8 liters would be sent as part of the next update from the sensor.

Note:

The Badger Meter Model A301W cable will work with all Series 300 products. However the older version of the cable (A300) does not have sufficient bandwidth to work with this receiver.

PROGRAMMING

Please note that no programming is required for the frequency output version of this system (electronics order code "U"). Simply enter the K and Offset information from the table below into the input device:

Model No.	K	Offset
228PV150U-xxxx-xxx	0.550342	-5.683758
228PV200U-xxxx-xxx	1.1544738	-1.3758585
228PV300U-xxxx-xxx	3.358104	-1.668902
228PV400U-xxxx-xxx	5.97996	0.440556

For the scaled pulse output version of this system, please proceed with software installation and programming instructions.

PROGRAMMING SOFTWARE INSTALLATION

Communications Cable Wiring

To change parameters in the receiver or sensor, a Badger Meter Model A301W Programming Kit (consisting of a custom cable, IR dongle, and software) and a PC running Windows® 9x, ME, NT, 2000 or XP is required. In order to program, the wireless receiver must be connected to power, and the communications cable must be connected to the D.I.C. Comm port and an available DB9 Comm. port on a computer.

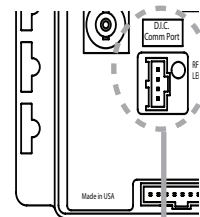

Location of the DIC Com Port

CDROM Installation

Insert the Badger Meter Model 350W WS/R CD into a CDROM drive of a Windows based PC. Software should start automatically. Follow instructions from the InstallShield Wizard to complete installation. From the Windows Start\ Programs\Badger Meter Inc. menu, select Model 350W to start the application software.

Web Installation

Badger Meter provides free programming software updates via the Internet for all field programmable devices. The installation software can be found in the support section of the Data Industrial website (www.dataindustrial.com).

WIRELESS RECEIVER PROGRAMMING

To change settings in the wireless receiver, Badger Meter software must be installed and the new values entered using a Windows based program as outlined below.

1. Install the 350 wireless PC software into the computer.
2. Connect the computer to the wireless receiver using the Badger Meter Model A301W communications cable. Plug the Model A301W cable to the socket labeled "D.I.C. Comm Port" taking care to properly align the tab on the plug and socket to maintain polarity. Then plug the DB9 connector of the Badger Meter Model A301W communications cable to an available PC Com port that has the wireless sensor software installed. If a DB9 connector is not available, a USB to DB9 adapter (ex IOGEAR GUC232A) are available, and can be used.
3. Connect the wireless receiver to a power supply.
4. Open the 350 Wireless PC Software.
5. Select the Model 350WR as shown below.

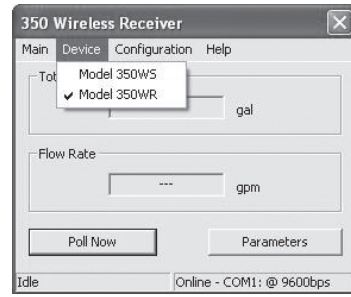

6. Select configuration and open the Set Comm Port screen to set the appropriate comm port for the A301W cable as shown in the dialog boxes below.

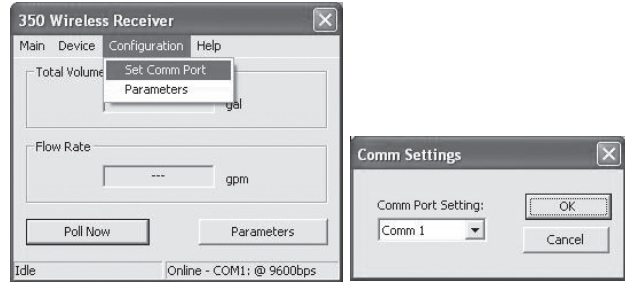

7. Open the Parameters screen.

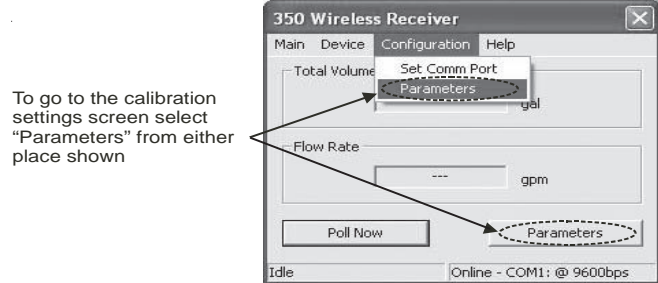

To go to the calibration settings screen select "Parameters" from either place shown

8. Program wireless receiver using diagram below as a reference.

Step 1

Enter serial number of wireless transmitter. This information can be found on the cable between sensor and transmitter or engraved on transmitter body.

Note: If serial number is eight digits in length and starts with the number "7", the leading "7" should not be entered. Otherwise all digits should be entered.

Step 3

Enter the desired volume per scaled output pulse.

Step 5

Configure this selection depending on the application requirements.

Step 6

Press the send button to calibrate the wireless receiver with the information that was entered in steps 1-5

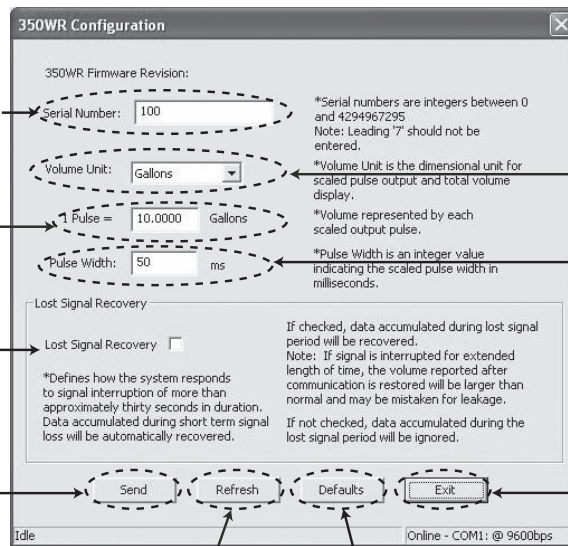

Step 2

Enter the desired volume unit for scaled output pulses

Step 4

Enter the scaled output pulse width. **Note: The default pulse width is 50 milliseconds. Minor variation in pulse width may be required depending on controller interface.**

Step 7

Press to exit Parameters screen

If Required
Press to see current programming of the wireless receiver

If Required
Press to enter in the factory default programming. **Note: This will overwrite all settings.**

WIRELESS FLOW SENSOR PROGRAMMING

The wireless flow sensor is factory programmed based on the line size for your application using the default settings given in the table, below (based on 15 fps flow velocities.)

Model No.	K	Offset	Recommended Volume / Pulse Output (gallons)	Minimum / Maximum Flow Range (gpm)
228PV150W-xxxx-xxx	0.275171	-11.367570	1	6 - 95
228PV200W-xxxx-xxx	0.577369	-2.751717	1	10 - 156
228PV300W-xxxx-xxx	1.679052	-3.337804	10	23 - 345
228PV400W-xxxx-xxx	2.989980	0.881112	10	39 - 595

These factory settings consist of the K and Offset values and Gallons per Pulse Output.

The K and Offset values, empirically derived from flow test using NIST traceable instruments, are used in the calibration equation ($\text{Frequency} = \text{GPM}/\text{K} - \text{Offset}$) to calculate sensor frequency at any flow rate within its operational range. Factory settings for K and Offset are normally changed only when installing the sensor in a different line size or when custom values are required, e.g. non-standard piping. Should custom values for K and Offset be required, contact the factory for assistance. Note: If no line size is specified at the time of order placement, default values for K and Offset of 0.5 and 0, respectively, will be used.

The value for Gallons per Pulse Output sets system resolution. Lowering the factory default value for gallons per pulse output is not recommended because it will decrease transmitter battery life and may affect transmitter operation.

Badger Meter sensors will operate both above and below the suggested flow range for each tee size. Test results have shown, however, that the highest accuracy and best repeatability are achieved in this flow range.

To change settings in the wireless sensor, Badger Meter software must be installed and new values entered using a Windows® based program as outlined below.

1. Open the 350 Wireless PC Software.
2. Connect the computer to the wireless sensor using an infrared cable (IR dongle).
Note: IR Device must be placed no more than 3 inches from top of sensor.

6. Program wireless sensor using diagram below as a reference.

Step 1
Select sensor size from pull down menu. If the a custom K and offset are required select "other" (unlisted) from the pull down menu.

Step 4
Press the send button to calibrate the wireless sensor with the information that was entered in steps 1-3

The K and offset numbers will automatically appear here for the flow sensor size selected. If "other" was selected in step 1 enter in desired k and offset numbers

Step 2
Enter the desired unit for flow rate display.

Step 3
Enter desired volume per output pulse.

Step 5
Press to exit Parameters screen

If Required
Press to see current programming of the wireless sensor

If Required
Press to enter in the factory default programming. **Note: This will overwrite all settings.**

3. Select the Model 350WS as shown below.

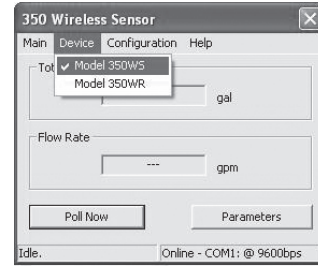

4. Open the interface software then select Configuration and Set Comm Port and select the appropriate Comm Port for the IR cable as shown in the dialog boxes below.

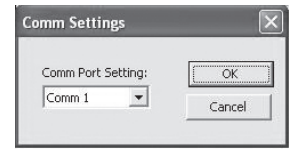
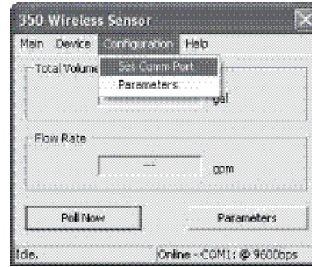

5. Open the Parameters screen.

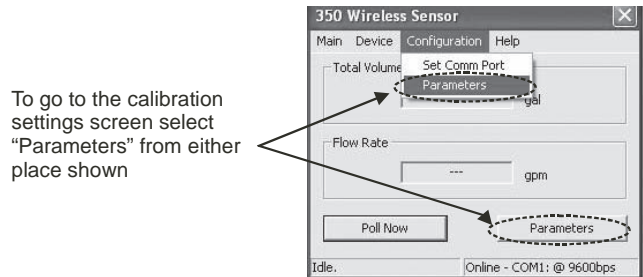

SPECIFICATIONS

Wetted Materials (Except Tee)

- Refer to the Sensor Selection Matrix

Tee for 228PV

- Schedule 80 PVC per ASTM D-2462 and D-2467. Virgin, unplasticized PVC resin, Type 1 cell classification 12454-B. Fittings and solvent carry approval for potable water by NSF and IAMPO.

Power Requirements

- Flow sensor-lithium battery powered (typical battery life - > 5yr)
- ORION® transmitter-battery powered (typical battery life > 10yr)
- ORION receiver-external power 12-24VAC/VDC
Current Draw:
36 mA @ 12 VDC
16 mA @ 24 VDC
40 mA rms @ 12 VAC rms
30 mA rms @ 24 VAC rms

Recommended Flow Range

- 5 to 20 FPS
- Extended flow range 1 to 20 FPS

Accuracy

- Standard $\pm 2\%$ of rate
- Repeatability $\pm 0.5\%$

SENSOR PRESSURE RATINGS

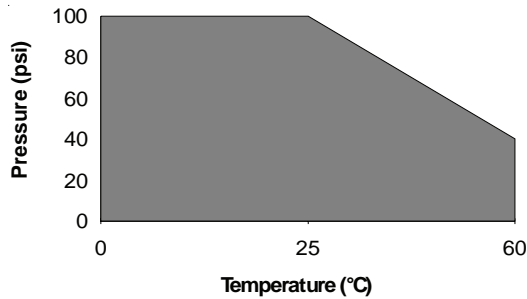

MINIMUM SCALED PULSE OUTPUT

- Scaled pulse output from the sensor and Badger® ORION RF receiver are programmed using PC software. Minimum recommended pulse output from the sensor for various "tee" sizes are listed below. (Based on 15 FPS flow velocities)

Tee Size	Gal/Pulse
1.5"	1
2"	1
3"	10
4"	10

Badger® and ORION® are registered trademarks of Badger Meter, Inc. Windows® is a registered trademark of The Microsoft Corporation.

Maximum Operating Temperature

- 32 - 150°F (0 - 65°C)

Sensor Pressure Drop

- 0.5psi or less at 10 FPS for all pipe sizes 1.5" diameter and larger

Programming

- Sensor and transmitter programming is accomplished using PC software via an infrared (IR) link
- ORION RF receiver programming is accomplished using PC software via the A301W connector cable

Flow Sensor

Programmable Parameters

- K & Offset dependent upon pipe size
- Flow units (gpm, gph, lps, lpm, ft³/sec, ft³/min, m³/sec, m³/min)
- Scaled pulse output (units/pulse)

ORION Transmitter

Programmable Parameters

- Customer programming not required

ORION Receiver

Programmable Parameters

- Serial number (unique to the ORION Transmitter ID)
- Volume units (gallons, ft³, m³, ltrs)
- Scaled pulse output (units/pulse)
- Scaled pulse output (pulse width)

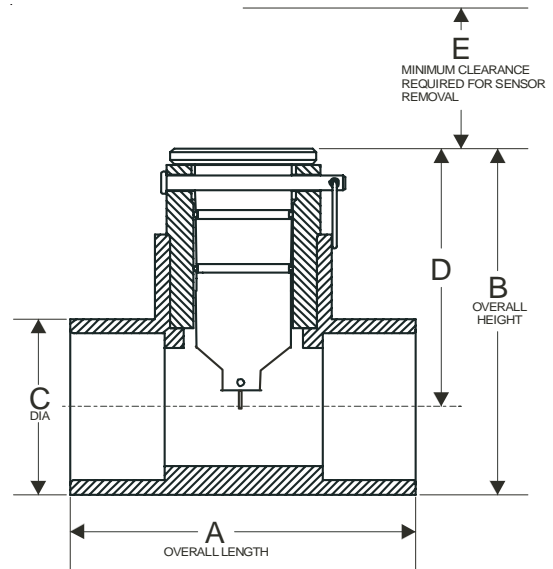

Series No. Complete	228PV152W-1201	228PV202W-1201	228PV302W-1201	228PV402W-1201
A	5.0" (127mm)	5.63 (143mm)	6.50" (165mm)	7.38" (187mm)
B	5.16" (131mm)	5.64" (143mm)	6.83" (173mm)	6.83" (199mm)
C	2.38" (60mm)	2.88" (73mm)	4.23" (107mm)	5.38" (137mm)
D	3.97" (101mm)	4.20" (107mm)	4.68" (119mm)	5.10" (130mm)
E	5.5" (139.7mm)	5.5" (139.7mm)	5.5" (139.7mm)	5.5" (139.7mm)



Please see our website at www.badgermeter.com for specific contacts.

Copyright © Badger Meter, Inc. 2008. All rights reserved.

Due to continuous research, product improvements and enhancements, Badger Meter reserves the right to change product or system specifications without notice, except to the extent an outstanding contractual obligation exists.



BadgerMeter, Inc.

6116 E. 15th Street, Tulsa, Oklahoma 74112

(918) 836-8411 / Fax: (918) 832-9962

www.badgermeter.com