

Joslyn Clark 



CATALOG #250

WWW.DANAHERSPECIALTYPRODUCTS.COM

TABLE OF CONTENTS

Vacuum Control.....	Low Voltage, Medium Voltage.....	A
NEMA Control - Heavy Duty.....	TM, 5000.....	B
NEMA Control - General Duty....	HP.....	C
Pilot Devices, Pilot Lights.....	Pushbuttons, Selectors Switches.....	D
Mill Duty Products.....	Limit Switch, Foot Switches, Palm Switches....	E
D.C. Control/RHEO Stats.....	146, 5DP, 7400.....	F
Relays.....	PM, 447.....	G
Lighting Contactors.....	Type PM-LC20, LC30, 447, TM-LC.....	H
Replacement Coil Data & Reference Pages.....		I



CATALOG INFORMATION

HOW TO USE THIS CATALOG

Joslyn Clark Controls is pleased to announce the newest edition of our CONTROLLOG catalog. This catalog is designed to be an easy to use reference for selecting, pricing, and ordering our unique, comprehensive line of motor controls.

The thumbtab index on page 1 shows the family groups of products used in this catalog. For instance, Tab A is printed on the outside edge of all pages of vacuum control. Included in this section are all vacuum contactors and starters, and all accessories such as factory modifications, heaters, dimensions, and engineering data.

The header at the top of each page lists the product family and the specific product cataloged on that page. For instance a page in the B section may say: NEMA CONTROL™ STARTERS.

Each page with catalog numbers also includes all ordering information in an area at the bottom of the page. Information here includes dimensions, and heater selection.

WARNING

Joslyn Clark Controls, LLC products are designed and manufactured for use in standard commercial, industrial, and residential applications. These products must be installed and used in accordance with the provisions of the U.S. National Electrical Code and or all other State and local codes and industry standards that apply. Installation or use not in accordance with these codes and standards could be hazardous to personnel and/or equipment.

REGULATION 10 CFR 21

Equipment sold by Joslyn Clark Controls, LLC is not intended to be used, nor should it be used, as conforming to Government Regulations 10 CFR 21 (NRC).

STANDARD CONDITIONS OF SALE Applicable to Joslyn Clark Controls, LLC Products

1. ACCEPTANCE OF ORDERS, MODIFICATIONS AND CANCELLATIONS

Joslyn Clark Controls, LLC representatives are not authorized to make oral offers to sell products. Offers to sell are made in the form of written quotations only. Oral quotations are invitations for the purchaser to submit an order per the quotation. Such solicited orders are subject to acceptance or rejection by Joslyn Clark Controls, LLC as set forth below. Written quotations automatically expire thirty (30) calendar days from date issued unless sooner terminated by notice. Prices stated in written quotations are subject to the pricing terms specified below. All clerical errors in quotations are subject to correction. Joslyn Clark Controls, LLC publications are maintained as sources of general information and are not quotations or offers to sell.

No order for products shall be binding upon Joslyn Clark Controls, LLC until accepted by issuance of Joslyn Clark Controls, LLC printed acknowledge form or by shipment. Any such order shall be subject to these standard conditions of sale and acceptance shall be conditioned on assent to these conditions, which assent shall be deemed given unless purchaser shall expressly notify Joslyn Clark Controls, LLC to the contrary within five days after receipt of acknowledgment or confirmation of an order, and in all events prior to delivery or other performance by Joslyn Clark Controls, LLC against such order. Failure of Joslyn Clark Controls, LLC to object to provisions contained in any purchase order or other communications from a purchaser (including, without limitation penalty clauses of any kind) shall not be construed as a waiver of these conditions nor any acceptance of any such provisions.

No order accepted by Joslyn Clark Controls, LLC may be altered or modified by purchaser unless agreed to in writing signed by an authorized representative of Joslyn Clark Controls, LLC. No order may be cancelled or terminated except upon payment of any loss, damage and expense incurred by Joslyn Clark Controls, LLC arising from such cancellation or termination.

2. DELIVERY

Delivery to a carrier at any Joslyn Clark Controls, LLC plant or other shipping point shall constitute delivery to purchaser; and, regardless of freight payment, title and all risk of loss or damage in transit shall pass to purchaser upon delivery to the carrier.

Care is taken in packing products, but Joslyn Clark Controls, LLC cannot be held responsible for breakage after delivery to the transportation company. All claims for loss and damage must be made by purchaser to the carrier. Claims for shortage or other errors must be made in writing to Joslyn Clark Controls, LLC within ten (10) days after receipt of shipment, and failure to give such notice shall constitute unqualified acceptance and a waiver of all such claims by purchaser.

Freight Allowed terms, as set forth in Distributor Price Schedules issued from time to time by Joslyn Clark Controls, LLC are incorporated herein and hereby made a part of these Standard Conditions of Sale.

Joslyn Clark Controls, LLC reserves the right to determine shipment methods and routings. For special routing or handling requested, additional transportation charges will be added to the invoice. No allowance will be made in lieu of transportation if purchaser accepts shipments at factory, warehouse, freight station, or otherwise supplies its own transportation. Weights shown in Joslyn Clark Controls, LLC literature are approximate.

In the event of a product shortage, Joslyn Clark Controls, LLC reserves the right to allocate its available production or substitute products.

Joslyn Clark Controls, LLC reserves the right to make delivery in installments, unless otherwise expressly stipulated on the face of the purchaser's order; and all such installments when separately invoiced shall be paid for when due per invoice, without regard to subsequent deliveries. Delay in delivery of any installment shall not relieve purchaser of its obligation to accept remaining deliveries.

Joslyn Clark Controls, LLC shall not be liable for any damage as a result of any delay due to any cause beyond its reasonable control, including, without limitation, an act of God; an act of purchaser; embargo or other government act, regulation or request; fire, accident; strike, slowdown; wars; riots; delay in transportation; and inability to obtain necessary labor, materials or manufacturing facilities. In the event of any such delay, the date of delivery shall be extended for a period equal to the time lost by reason of delay.

3. PRICES

Prices set forth in Joslyn Clark Controls, LLC catalogs and price schedules are subject to change without notice. In the event of a net price change, the price of equipment on order but unshipped will be adjusted to the price in effect at time of shipment, including equipment on order pursuant to written quotations unless the quotation provides otherwise on its face. Downward adjustment of prices shall apply only to unshipped portions of outstanding orders.

Joslyn Clark Controls, LLC reserves the right at any time to demand full or partial payment before proceeding with any order or contract of sale if, in its judgement, the financial condition of purchaser does not justify the terms of payment specified. If delivery is delayed or deferred beyond Joslyn Clark Controls, LLC scheduled shipment date, payment shall be due in full when Joslyn Clark Controls, LLC is prepared to ship, and the equipment so delayed or deferred by purchaser may be stored by Joslyn Clark Controls, LLC at the risk and expense of the purchaser. If purchaser defaults when payment is due then the whole contract price shall become due and payable on demand, or Joslyn Clark Controls, LLC at its option, without prejudice to other lawful remedies, may defer delivery or cancel the contract of sale.

4. PAYMENT TERMS

Payment terms as set forth in Distributor Price Schedules issued from time to time by Joslyn Clark Controls, LLC are incorporated herein and hereby made a part of these Standard Conditions of Sale. Invoices will be issued and are payable as partial shipments are made.

5. TAXES AND OTHER CHARGES

All taxes shall be paid by purchaser in addition to prices quoted or invoiced. In the event Joslyn Clark Controls, LLC shall be required to pay any such tax, fee or charge, purchaser shall reimburse Joslyn Clark Controls, LLC therefore; or in lieu of such payment purchaser shall provide Joslyn Clark Controls, LLC at the time the order is submitted an exemption certificate or other document acceptable to the authority imposing the tax, fee or charge. Purchase orders must state the existence and amount of any such tax, fee or charge which it shall be Joslyn Clark Controls, LLC responsibility to collect from purchaser and pay.

6. WARRANTIES

Joslyn Clark Controls, LLC warrants for a period of one year from the date of shipment that any product manufactured by it and sold to purchaser hereunder will be free from defects in material or workmanship at the time of delivery to the carrier. Joslyn Clark Controls, LLC sole responsibility in the event of such defect material or workmanship in violation of the warranty shall be, at Joslyn Clark Controls, LLC option, to repair, replace or refund the original purchase price of any defective product. Joslyn Clark Controls, LLC products are designed and manufactured for use in standard commercial, industrial and residential applications. If these products are to be used in any location which might be of a hazardous nature, such as atomic installations, commercial or military aircraft, missile installations, space explorations or in any other critical application where failure of a single component could cause substantial harm to persons or property, Joslyn Clark Controls, LLC disclaims all responsibility unless it has received a complete description of the application and has concurred that the product in question is suitable for the proposed application. Such concurrence must be signed by a Joslyn Clark Controls, LLC officer. THE AFORESAID WARRANTY IS IN LIEU OF ALL OTHER WARRANTIES, EXPRESSED OR IMPLIED, AND JOSLYN CLARK CONTROLS, LLC EXPRESSLY DISCLAIMS ANY WARRANTY OF MERCHANTABILITY OR FITNESS FOR A PARTICULAR PURPOSE.

7. REMEDIES ARE EXCLUSIVE

The remedies of the purchaser set forth herein are exclusive and the liability of Joslyn Clark Controls, LLC with respect to any contract or anything done in connection therewith such as the performance or breach thereof, or from the manufacture, sale delivery, resale or use of any equipment covered by or furnished under the contract, whether in contract, in tort (including negligence and strict liability) or otherwise, shall not exceed the price of the equipment or part on which such liability based.

8. LIMITATION OF LIABILITY

JOSLYN CLARK CONTROLS, LLC WILL NOT BE LIABLE FOR ANY CONSEQUENTIAL, SPECIAL, CONTINGENT OR INCIDENTAL DAMAGES WHATSOEVER, INCLUDING WITHOUT LIMITATION, PENALTIES SUFFERED BY PURCHASER AS THE RESULT OF ANY BREACH OF CONTRACT, BREACH OF WARRANTY OR TORTIOUS ACT COMMITTED IN CONNECTION WITH ITS SUPPLYING OR FAILURE TO SUPPLY EQUIPMENT PURSUANT TO ANY ORDER OR OTHER CONTRACT OR FOR ANY LABOR COSTS INCURRED AS A RESULT THEREOF.

9. PATENT PROTECTION

If Joslyn Clark Controls, LLC is notified promptly by the purchaser in writing and is given authority, information and assistance for the settlement or defense of any action or assertion brought against the purchaser insofar as it is based upon a direct infringement of a claim or claims of one or more U.S. patents or trademarks electronic equipment products purchased from and manufactured by Joslyn Clark Controls, LLC, standard commercial items when used or sold for the purposes for which such products are customarily used, Joslyn Clark Controls, LLC will defend or settle such actions or proceedings and will satisfy settlement of a final award for such infringement against the purchaser but Joslyn Clark Controls, LLC assume no liability, consequential or otherwise, for and the purchaser agrees to hold Joslyn Clark Controls, LLC harmless from infringements of patent claims covering a method or process in which any such products may be used or covering the equipment, assembly, circuit, system or combination in which any such products may be used as a component, or from any trademark infringements involving any marking or branding applied at the request of the purchaser. Joslyn Clark Controls, LLC assumes no liability, consequential or otherwise, for and the purchaser agrees to indemnify and hold Joslyn Clark Controls, LLC harmless against any claims resulting from production of articles or materials which are manufactured by Joslyn Clark Controls, LLC to the purchaser's specifications or from the production of articles or materials designed by Joslyn Clark Controls, LLC to meet the purchaser's requirements arising out of the use of any equipment, materials, parts or machinery furnished by the purchaser in making products to purchaser's specifications. No costs or expense under this paragraph shall in any event be incurred for the account of Joslyn Clark Controls, LLC without its written consent.

10. RETURN OF GOODS

No Joslyn Clark Controls, LLC product may be returned without first obtaining Joslyn Clark Controls, LLC written permission, and all returns will be subject to the Return Goods Policy in effect when the return goods request is submitted to Joslyn Clark Controls, LLC. No returns will be allowed for any custom-built products under any circumstances.

11. SALES CONVEYS NO LICENSE

Joslyn Clark Controls, LLC sale of products does not convey any license, expressly or by implication, estoppel or otherwise, under any patent claim with respect to which Joslyn Clark Controls, LLC can grant licenses covering a completed equipment or any assembly, circuit, combination, method or process in which any such products are used as components (notwithstanding the fact that such products may have been designed for use in, or may only be useful in, such patented equipment, assembly, circuit, combination, method or process, and that such products may have been purchased and sold for such use). Joslyn Clark Controls, LLC expressly reserves all its rights under such patent claims.

12. PURCHASER'S COMPLIANCE WITH LAWS

Joslyn Clark Controls, LLC does not assume any liability for the purchaser's compliance with or adherence to any federal, state or local laws or regulations.

13. ORDER OF PRIORITY

In the event of any conflict between the standard conditions of sale applicable to Joslyn Clark Controls, LLC products and the terms of any contract entered into between Joslyn Clark Controls, LLC and the purchaser, the Joslyn Clark Controls, LLC standard conditions of sale shall prevail.

14. GOVERNING LAW

All contracts for the sale of Joslyn Clark Controls, LLC products shall be governed and construed according to the laws of the State of Delaware.



CV Series	Page Number
Low Voltage 200V-1500V	
AC Contactors CV4.....	A2
AC Reversing Contactor CV4	A3, A4
AC Starters CV4.....	A5
Rev Starter CV4	A6
Technical Specifications CV4,5&6	Diagrams & A7, A13, A19 Dimensions
AC Contactors CV5.....	A8
AC Reversing Contactors CV5	A9, A10
AC Starters CV5.....	A11
AC Rev Starters CV5.....	A12
AC Contactor CV6.....	A14
AC Reversing Contactors CV6	A15, A16
AC Starters CV6.....	A17
AC Rev Starters CV6.....	A18
CV Series Starter O/L Heaters	A35
VC Series	
Low Voltage 200V - 3.6KV	
AC Contactors, 200V - 3.6KV.....	A20
AC Contactors (Mechanically Latched).....	A21
AC Reversing Contactors 200V - 3.6KV	A22, A23
AC Starters 200V - 3.6KV.....	A24
AC Reversing Starters 200V - 3.6KV.....	A25
AC Combination Starters 200V - 1.5KV	A26, A27
AC Reduced Voltage Auto Transformer Starters 600V	A28
AC Special Purpose Contactors - 200V - 3.6KV, 160-2500 amp.	A29
Technical Specifications	A30
Dimensions.....	A31, A34
AC Vacuum Starters Overload Heaters.....	A35
Parts/Accessories	A36
Low Voltage Modifications.....	A37, A38
MVC Series	
Medium Voltage 2.5 - 7.2KV (Contactors)	A39
AC Contactors - 2.5, 5.0, 7.2KV (Mechanically Latched)	A40
AC Contactors (Mechanically Interlocked).....	A41
AC Special Purpose Contactors - 2.5, 5.0, 7.2KV, 200-3000 amp.	A42
Technical Specifications	A43
Dimensions.....	A44, A45
Medium Voltage Controllers	A46, A48
Medium Voltage Modifications	A49, A50

USAVAC - LOW VOLTAGE

AC Vacuum Contactors

A

- UL listed to 1500V
- CSA Certified to 1500V
- CE
- Three Ratings
- One Small Size

CV Series
NEMA Size 4 V200
IEC 200A



600V NEMA Size 4 135A

600Volt Nema Size 4 135A Contactor 3 Pole Nema ICS-2 UL508 CSA 22.2

Rating Nema Size 4	Maximum Horsepower KW Rating 3 Phase HP/KW				Open Type
	600V	200V	230V	460V	575V
HP/KW	40/30	50/37	100/75	100/75	CV77U030406-*

660Volt 200AMP Contactor 3 Pole IEC 947-4-1 UL508 CSA 22.2

Rating 200A	Maximum Horsepower/KW Rating 3 Phase HP/KW								Open Type
	1000V	200/208V	220/240V	380/400V	415/440V	460V	500V	575/600V	660-690V
HP/KW	50/37	75/59	100/75	125/95	150/110	190/140	200/150	250/185	CV77U032006-*

1500Volt 200AMP Contactor 3 Pole IEC 947-4-1 (1000V) UL508 (1500V) CSA 22.2 (1500V)

Rating 200A Nema V200	Maximum Horsepower/KW Rating 3 Phase HP/KW							Open Type
	1500V	200/208V	220/240V	400V	460V	575/600V	1000V	1500V
HP/KW	50/37	75/59	125/95	150/110	175/130	300/225	500/370	CV77U031615

Options Discount (Schedule JC11) Field Kits

Description	Catalog #
Lug Kit #6 to 250mcm 3 Per Kit	KVC4-2
Aux. Contact Kit 2N/O 2N/C 10A 600VAC	AK1
Aux. Contact Kit 2N/O 2N/C 10MA 5VDC	AK3

Replacement Parts (Discount Schedule JC80)

Description	Catalog #
Interrupter Phase Assembly	A77-457211A
Coil 110/120V 50/60 HZ	A77-460915A-1
Coil 220/240V 50/60 HZ	A77-460915A-2
Coil 380/415V 50/60 HZ	A77-460915A-3
Coil 440/480V 50/60 HZ	A77-460915A-4
Coil 125V DC	A77-460915A-5
Coil 250V DC	A77-460915A-6
Control PAK 110/120 50/60 HZ	A77-460916A-1
Control PAK 220/240 50/60 HZ	A77-460916A-2
Control PAK 380-415V 50/60 HZ	A77-460916A-3
	440-480V 50/60 HZ
Aux. Contact Kit 2N/O 1N/C +1 N/C	AKStd. Late Break

Ordering Information

* Coil Table

- Use complete catalog number when ordering.
- Replace the (*) with the suffix from the coil table.
- Engineering Data page A7.
- Renewal Parts page A2.

	Voltage Suffix
120 AC	-76
240 AC	-26
380 AC	-38
460 AC	-46
125V DC	-125
250V DC	-250

USA VAC - LOW VOLTAGE

AC Mechanical Interlocked Vacuum Contactors Unwired

A

- **UL listed to 1500V**
- **CSA Certified to 1500V**
- **CE**
- **NEMA Size 4 & V 200 1500V**
- **IEC 200A**
- **Three Ratings**
- **One Small Size**
- **Use for Reversers, Reduced Voltage Auto Transformer, Wye-Delta, 2 speed single winding, or 2 speed 2 winding applications**

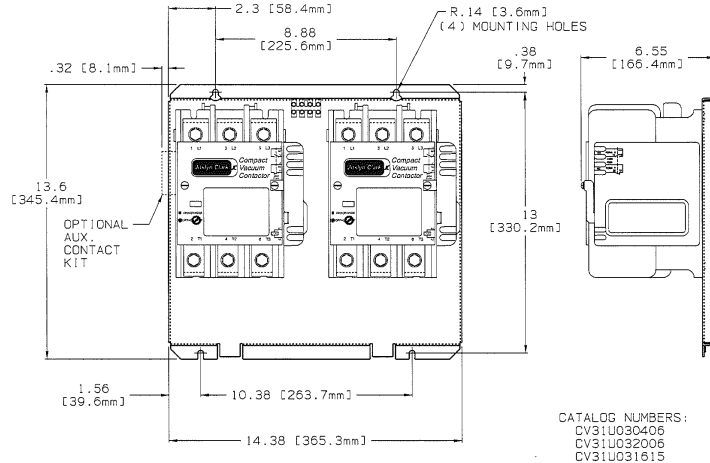

3 Pole Nema Rated ICS-2 UL508 CSA 22.2 Size 4 Mechanically Interlocked Pair Unwired 600V 135A Contactor

Rating Nema Size 4	Maximum Horsepower/KW Rating 3 Phase HP/KW				Open Type
600V	200V	230V	460V	575V	Catalog #
HP/KW	40/30	50/37	100/75	100/75	CV31U030406-* -43

3 Pole IEC947-4-1 UL508 CSA 22.2 Mechanically Interlocked Pair Unwired 660V 200A

Rating 200A	Maximum Horsepower/KW Rating 3 Phase					Open Type
1000V	200/208V	220/240V	380/415V	460V	575/660V	Catalog #
HP/KW	50/37	75/59	100/75	150/110	200/150	CV31U032006-* -43

3 Pole Nema Rated ICS-29 IEC947.4.1 (1000V) UL508 1500V CSA 22.2 Mechanically Interlocked Pair Unwired 1500V 200A Contactor

Rating 200A Nema V200	Maximum Horsepower/KW Rating 3 Phase							Open Type
1500V	200/208V	220/240V	380/415V	460V	575/660V	1000V	1500V	Catalog #
HP/KW	50/37	80/59	100/75	150/110	200/150	300/225	500/370	CV31U031615-* -43

Replacement Parts (Discount Schedule JC80)

Description	Catalog #
Interrupter Phase Assembly	A77-457211A
Coil 110/120V 50/60 HZ	A77-460915A-1
Coil 220/240V 50/60 HZ	A77-460915A-2
Coil 380/415V 50/60 HZ	A77-460915A-3
Coil 440/480V 50/60 HZ	A77-460915A-4
Coil 125V DC	A77-460915A-5
Coil 250V DC	A77-460915A-6
Control PAK 110/120 50/60 HZ	A77-460916A-1
Control PAK 220/240 50/60 HZ	A77-460916A-2
Control PAK 380-415V 50/60 HZ 440-480V 50/60 HZ	A77-460916A-3
Aux. Contact Kit 2N/O 1N/C +1 N/C Late Break	AK Std.

Options Discount (Schedule JC11)

Description	Catalog #
Lug Kit #6 to 250mcm 3 Per Kit	KVC4-2
Aux. Contact Kit 2N/O 2N/C 10A 600V ac	AK1
Aux. Contact Kit 2N/O 2N/C 10MA 5V dc	AK3

Plug Stop Jogging Duty

Nema Size	200V	230V	400V	460V	575V
4	25HP	30HP	50HP	60HP	—
V200	40HP	60HP	75HP	100HP	125HP

Ordering Information

	* Coil Table	
	Voltage Suffix	
• Use complete catalog number when ordering.	120 AC	-76
• Replace the (*) with the suffix from the coil table.	240 AC	-26
• Engineering Data page A7.	380 AC	-38
• Renewal Parts page A3.	460 AC	-46
	125V DC	-125
	250V DC	-250

USAVAC - LOW VOLTAGE

AC Reversing Vacuum Contactors Wired

A

3 Pole Nema Rated ICS-2 UL508 CSA 22.2 Size 4
Mechanically Interlocked Pair Wired 600V 135A Contactor

Rating Nema Size 4	Maximum Horsepower/KW Rating 3 Phase HP/KW					Open Type
	600V	200V	230V	460V	575V	
HP/KW	40/30	50/37	100/75	100/75	CV31U030406-*	

- UL listed to 1500V
- CSA Certified to 1500V
- CE
- Three Ratings
- One Small Size
- CV Series Nema Size 4 & V200
- IEC 200A

3 Pole IEC947-4-1 UL508 CSA 22.2
Mechanically Interlocked Pair Wired 660V 200A

Rating 200A	Maximum Horsepower/KW Rating 3 Phase					Open Type
	1000V	200/208V	220/240V	380/415V	460V	
HP/KW	50/37	75/59	100/75	150/110	200/150	CV31U032006-*

WIRED CONTACTORS

3 Pole Nema Rated ICS-29 IEC947 4.1 (1000V) UL508 1500V CSA 22.2
Mechanically Interlocked Pair Wired 1500V 200A Contactor

Rating 200A Nema V200	Maximum Horsepower/KW Rating 3 Phase								Open Type
	1500V	200/208V	220/240V	380/415V	460V	575/660V	1000V	1500V	
HP/KW	50/37	80/59	100/75	150/110	200/150	300/225	500/370	CV31U031616-*	

**NOT AVAILABLE,
SEE PAGE A4 FOR**

MECHANICALLY INTERLOCKED UNITS OR CALL FACTORY

Options Discount (Schedule JC11)

Description	Catalog #
Lug Kit #6 to 250mm ² Per Kit	KVC4-2
Aux. Contact Kit 2N/O 2N/C 10A 600V ac	AK1
Aux. Contact Kit 2N/O 2N/C 10MA 5V dc	AK3

Plug Stop Jogging Duty

Nema Size	200V	230V	400V	460V	575V
4	25HP	30HP	50HP	60HP	-
V200	40HP	60HP	75HP	100HP	125HP

Ordering Information

- Use complete catalog number when ordering. Replace the (*) with the suffix from the coil table.
- Engineering Data page A7.
- Renewal Parts page A4.

* Coil Table

Voltage	Suffix
120 AC	-76
240 AC	-26
380 AC	-38
460 AC	-46
125V DC	-125
250V DC	-250

Replacement Parts (Discount Schedule JC80)

Description	Catalog #
Interrupter Phase Assembly	A77-457211A
Coil 110/120V 50/60 HZ	A77-460915A-1
Coil 220/240V 50/60 HZ	A77-460915A-2
Coil 380/415V 50/60 HZ	A77-460915A-3
Coil 440/480V 50/60 HZ	A77-460915A-4
Coil 125V DC	A77-460915A-5
Coil 250V DC	A77-460915A-6
Control PAK 110/120 50/60 HZ	A77-460916A-1
Control PAK 220/240 50/60 HZ	A77-460916A-2
Control PAK 380-415V 50/60 HZ 440-480V 50/60 HZ	A77-460916A-3
Aux. Contact Kit 2N/O 1N/C +1 N/C Late Break	AK Std.

USAVAC LOW VOLTAGE AC Vacuum Starters

A

**CV Series
NEMA Size 4 V200A
IEC 200A**

- UL listed to 1500V
- CSA Certified to 1500V
- CE
- Three Ratings
- One Small Size

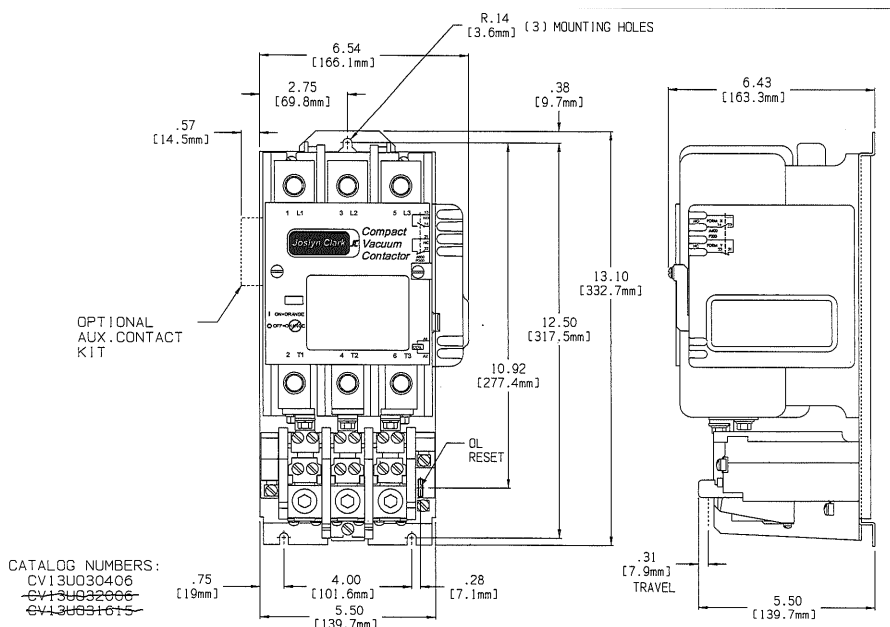

600VOLT NEMA SIZE 4 135A STARTER 3 POLE NEMA ICS-2 UL508 CSA 22.2

Rating Nema Size 4	Maximum Horsepower/KW Rating 3 Phase HP/KW				Open Type
600V	200V	230V	460V	575V	Catalog #
HP/KW	40/30	50/37	100/75	100/75	CV13U030406-*

660Volt 200AMP Starter 3 Pole IEC 947-4-1 UL508 CSA 22.2

Rating 200A	Maximum Horsepower/KW Rating 3 Phase HP/KW								Open Type
660V	200/208V	220/240V	380/400V	415/440V	460V	500V	575/600V	660-690V	Catalog #
HP/KW	50/37	75/59	100/75	125/95	150/110	190/140	200/150	250/185	CV13U032006-*

1500Volt 200 AMP Starter 3 Pole IEC 947-4-1 (1000V) UL508 (1500V) CSA 22.2 (1500V)

Rating 200A Nema V200	Maximum Horsepower/KW Rating 3 Phase HP/KW							Open Type
1500V	200/208V	220/240V	400V	460V	575/600V	1000V	1500V	Catalog #
HP/KW	50/37	75/59	125/95	150/110	175/130	300/225	500/370	CV13U031615-*

Replacement Parts (Discount Schedule JC80)

Description	Catalog #
Interrupter Phase Assembly	A77-457211A
Coil 110/120V 50/60 HZ	A77-460915A-1
Coil 220/240V 50/60 HZ	A77-460915A-2
Coil 380/415V 50/60 HZ	A77-460915A-3
Coil 440/480V 50/60 HZ	A77-460915A-4
Coil 125V DC	A77-460915A-5
Coil 250V DC	A77-460915A-6
Control PAK 110/120 50/60 HZ	A77-460916A-1
Control PAK 220/240 50/60 HZ	A77-460916A-2
Control PAK 380-415V 50/60 HZ 440-480V 50/60 HZ	A77-460916A-3
Aux. Contact Kit 2N/O 1N/C +1 N/C Late Break	AK Std.

Options Discount (Schedule JC11) Field Kits

Description	Catalog #
Lug Kit #6 to 250mcm 3 Per Kit	KVC4-2
Aux. Contact Kit 2N/O 2N/C 10A 600VA	AK1
Aux. Contact Kit 2N/O 2N/C 10MA 5VDC	AK3

Ordering Information

- Use complete catalog number when ordering. Replace the (*) with the suffix from the coil table.
- Engineering Data page A7.
- Renewal Parts page A5.

* Coil Table

Voltage	Suffix
120 AC	-76
240 AC	-26
380 AC	-38
460 AC	-46
125V DC	-125
250V DC	250

USAVAC - LOW VOLTAGE

AC Reversing Vacuum Starters

A

**CV Series
NEMA Size 4
IEC 200A**

- UL listed to 1500V
- CSA Certified to 1500V
- CE
- Three Ratings
- One Small Size
- CV Series Nema Size 4 & V200
- IEC 200A

**3 Pole Nema Rated ICS-2 UL508 CSA 22.2 Size 4
Mechanically Interlocked Pair Wired 600V 135A Starter**

Rating Nema Size 4	Maximum Horsepower/KW Rating 3 Phase HP/KW				Open Type
	600V	200V	230V	460V	575V
HP/KW	40/30	50/37	100/75	100/75	CV30U030406-*

**3 Pole IEC947-4-1 UL508 CSA 22.2
Mechanically Interlocked Pair Wired 660V 200A Starter**

Rating 200A	Maximum Horsepower/KW Rating 3 Phase					Open Type
	1000V	200/208V	220/240V	380/415V	460V	575/660V
HP/KW	50/37	75/59	100/75	150/110	200/150	CV30U032000-*

**3 Pole Nema Rated ICS-29 IEC947-4-1 1500V UL508 150V CSA 22.2
Mechanically Interlocked Pair Wired 500V 200A Starter**

Rating 200A Nema V200	Maximum Horsepower/KW Rating 3 Phase							Open Type
	1500V	200/208V	220/240V	380/415V	460V	575/660V	1000V	500V
HP/KW	50/37	80/59	100/75	150/110	200/150	300/225	500/370	CV30U031615-*

**WIRED CONTACTORS
NOT AVAILABLE,
SEE PAGE A4 FOR
MECHANICALLY INTERLOCKED
UNITS OR CALL FACTORY**

Options Discount (Schedule JC11)

Description	Catalog #
Lug Kit #6 to 250mcm 3 Per Kit	KVC4-2
Aux. Contact Kit 2N/O 2N/C 10A 600V ac	AK1
Aux. Contact Kit 2N/O 2N/C 10MA 5V dc	AK3

Plug Stop Jogging Duty

Nema Size	200V	230V	400V	460V	575V
4	25HP	30HP	50HP	60HP	-
V200	40HP	60HP	75HP	100HP	125HP

Ordering Information

* Coil Table

• Use complete catalog number when ordering.	120 AC	-76
• Replace the (*) with the suffix from the coil table.	240 AC	-26
• Engineering Data page A7.	380 AC	-38
• Renewal Parts page A6.	460 AC	-46
	125V DC	-125
	250V DC	-250

Replacement Parts (Discount Schedule JC80)

Description	Catalog #
Interrupter Phase Assembly	A77-457211A
Coil 110/120V 50/60	A77-460915A-1
Coil 220/240V 50/60	A77-460915A-2
Coil 380/415V 50/60	A77-460915A-3
Coil 440/480V 50/60	A77-460915A-4
Coil 125V DC	A77-460915A-5
Coil 250V DC	A77-460915A-6
Control PAK 110/120 50/60 HZ	A77-460916A-1
Control PAK 220/240 50/60 HZ	A77-460916A-2
Control PAK 380-415V 50/60 HZ 440-480V 50/60 HZ	A77-460916A-3
Aux. Contact Kit 2N/O 1N/C +1 N/C Late Break	AK Std.

USA VAC - LOW VOLTAGE AC VACUUM CONTACTORS & STARTERS

Engineering Data

A

Description	NEMA Size 4 600V	200 Amp 1000V	200 Amp 1500V
Cat #	CV 77U030406-*	CV 77U032006-*	CV 77U031615-*
Standard	NEMA 1CS-2 UL508 CSA22.2	IEC 947-4-1 UL508 CSA22.2	NEMA 1CS9-2 1500V IEC 947-4-1 1000V UL508 CSA22.2 1500V
Power Ratings Enclosed			
Insul. & Operating Volt	600 Volts	1000 Volts	1500 Volts
Rated Oper. AC1	135Amps	200 Amps	200 Amps
Rated Oper. AC3	100 HP 460/575V	250 HP 185KW-660V	500 HP 370KW-1500V
Rated Oper. AC4	60 HP 460/575V	175 HP-130KW-660V	315 HP-235KW-1500V
Rated Frequency	50 - 400 Hz		
Making Current	2000 Amps		
Breaking Current	1600 Amps		
Dielectric Strength	6Kv - 1 Min. Interrupter		
Interrupting Current	2.2 KA		
Short Time Current 1 Sec.	5000 A		
Short Time Current 10 Sec	1600 A		
Mechanical Life	1.2 X 10 ⁶		
Elect. Life AC3 Duty	1 X 10 ⁶		
Switching Frequency	600 / Hour (1 Every 6 Sec)		
Withstand Current	10KA50MSec		
Chop Current Max	0.9 A		
Operating Range	-15% + 10% - at Range Voltage		
Inrush Power VA	1200VA 20 ms Duration		
Holding Power VA	12 VA		
Opening Time MS	120ms		
Closing Time MS	20-40ms		
Pick-Up Voltage	80% Cold 85% Hot or less		
Drop-Out Voltage	70% or less		
Recommended CPT	400VA Machine Tool Transformer 5% Regulation at 20%pf		
Applications Ratings			
Mounting Installation	All Planes (Contactor only)		
Altitude	6600 ft. 2000 Meters		
Ambient Storage	-65°F (-54°C) +160°F (71°C)		
Operating	-40°F (-40°C) +122°F (50°C)		
Vibration / Shock	40Hz - 2G. / 30G.		
Weight	13 lbs. 5.9Kg.		

Motor HP/KW AC3		
Voltage	135A	200A
208	40/30	50/37
220/240	50/37	75/59
380/400	----	100/75
415/440	----	125/93
460	100/75	150/110
500	----	190/140
575/600	100/75	200/150
660/690	----	250/185
1000	----	300/225
1500	----	500/370
Three Phase Transformer Load KVA		
Voltage	135A	200A
208	54	72
220/240	57	55
380/400	99	135
415/440	108	152
460/500	119	173
575/600	130	207
660	171	225
1000	260	346
1500	390	519
Three Phase Capacitor Load KVAR		
Voltage	135A	200A
208	40	54
220/240	43	62
380/400	74	104
415/440	81	114
460	90	127
575/600	115	156
1000	195	260
1500	292	390

- Options**
- Lug Kit 2/O 250mcm (3 per kit) Cat.# KVC4-2
- Auxiliary Contact Kits**
- 2NO. 2NC 600V. 10A ac. Cat.# AK1
 - 2NO. 2NC 5V.10mA dc. Cat.# AK3
- Only 1 Kit can be added for total of 3 N/O 3 N/C contacts (1 N/O 1N/C is standard).*

Coils		
Description	Hz.	Cat.Suffix
110/120V	50/60Hz.	-76
220/240V	50/60Hz.	-26
380/415V	50/60Hz.	-38
440/480V	50/60Hz.	-46
125V DC		-125
250V DC		-250

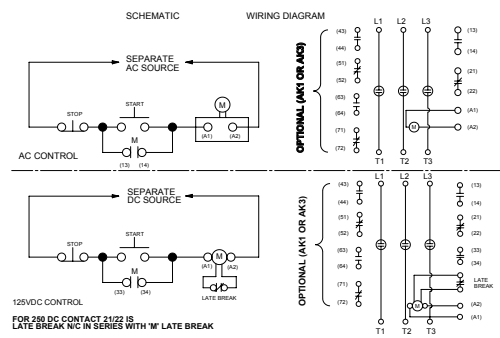
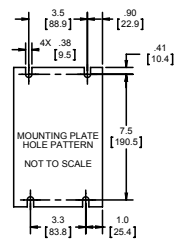
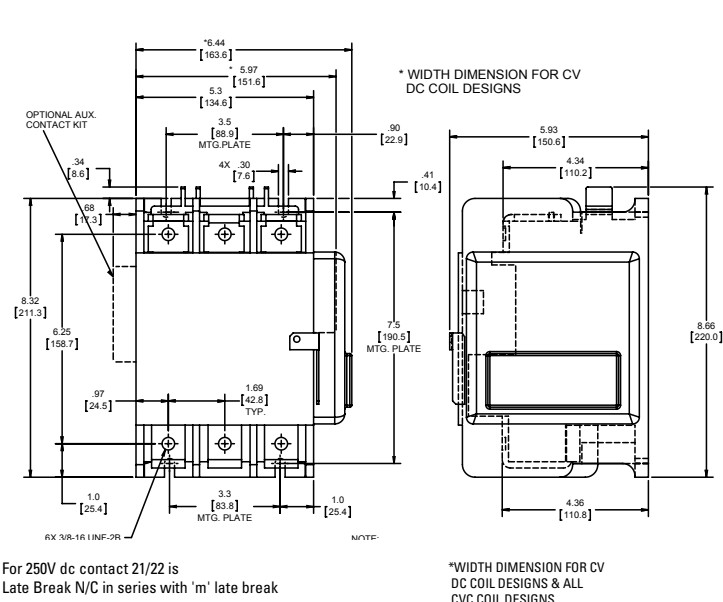

USAVAC - LOW VOLTAGE

AC Vacuum Contactors

A

**CV Series
NEMA Size 5
IEC 400A**

- UL listed to 1500V
- CSA Certified to 1500V
- CE
- Three Ratings
- One Small Size



600V NEMA Size 5 270A



1000V 400A

600Volt Nema Size 5 270A Contactor 3 Pole Nema ICS-2 UL508 CSA 22.2

Rating Nema Size 5	Maximum Horsepower/KW Rating 3 Phase HP/KW				Open Type Catalog #
	200V	230V	460V	575V	
600V	200V	230V	460V	575V	Catalog #
HP/KW	75/56	100/75	200/150	200/150	CV77U030506-*

1000Volt 400AMP Contactor 3 Pole IEC 947-4-1 UL508 CSA 22.2

Rating 400A	Maximum Horsepower/KW Rating 3 Phase HP/KW						Open Type Catalog #
	200/208V	220/240V	380/415V	460V	575/600V	660-690V	
1000V	200/208V	220/240V	380/415V	460V	575/600V	660-690V	Catalog #
HP/KW	100/75	150/112	250/187	300/220	400/300	450/336	CV77U034A06-*

1500V 400AMP Contactor 3 Pole IEC 947-4-1 (1000V) UL508 (1500V) CSA 22.2 (1500V)

Rating 400A	Maximum Horsepower/KW Rating 3 Phase HP/KW								Open Type Catalog #
	200/208V	220/240V	415/440V	460V	575/600V	660-690V	1000V	1500V	
1500V	200/208V	220/240V	415/440V	460V	575/600V	660-690V	1000V	1500V	Catalog #
HP/KW	100/75	150/112	250/187	300/220	400/300	500/370	700/520	850/650	CV77U034A15-*
Nema V320	100/70	125/95	200/150	300/220	300/220	-	500/370	900/670	CV77U033V15-*

Options (Discount Schedule JC11) Field Kits

Description	Catalog #
Lug Kit 3 Per Kit #4-500 mcm	KVC5-1
Lug Kit 3 Per Kit (2) #6-300 mcm	KVC5-2
Aux Contact Kit 2N/O 2N/C 10A 600VAC	AK1
Aux. Contact Kit 2N/O 2N/C 10MA 5VDC	AK3

Ordering Information

* Coil Table

<ul style="list-style-type: none"> • Use complete catalog number when ordering. Replace the (*) with the suffix from the coil table. • Engineering Data page A13. • Renewal Parts page A8. 	120 AC	-76
	240 AC	-26
	380 AC	-38
	460 AC	-46
	125V DC	-125
	250V DC	-250

Replacement Parts (Discount Schedule JC80)

Description	Catalog #
Interrupter Phase Assembly	A77-460880A-1
Coil 110/120V 50/60 HZ	A77-460930A-1
Coil 220/240V 50/60 HZ	A77-460930A-2
Coil 380/415V 50/60 HZ	A77-460930A-3
Coil 440/480V 50/60 HZ	A77-460930A-4
Coil 125V DC	A77-460930A-5
Coil 250V DC	A77-460930A-6
Control PAK 110/120 50/60 HZ	A77-460916A-4
Control PAK 220/240 50/60 HZ	A77-460916A-5
Control PAK 380-415V 50/60 HZ 440-480V 50/60 HZ	A77-460916A-6
Aux. Contact Kit 2N/O 1N/C +1 N/C Late Break	AK Std.

USAVAC - LOW VOLTAGE

AC Mechanically Interlocked Vacuum Contactors Unwired

A

- UL listed to 1500V
- CSA Certified to 1500V
- CE
- NEMA Size 5 & V320
- IEC 400A
- Three Ratings
- One Small Size
- Use for Reversers, Reduced Voltage Auto Transformer Starters, Wye-Delta, 2 speed single winding, starter applications

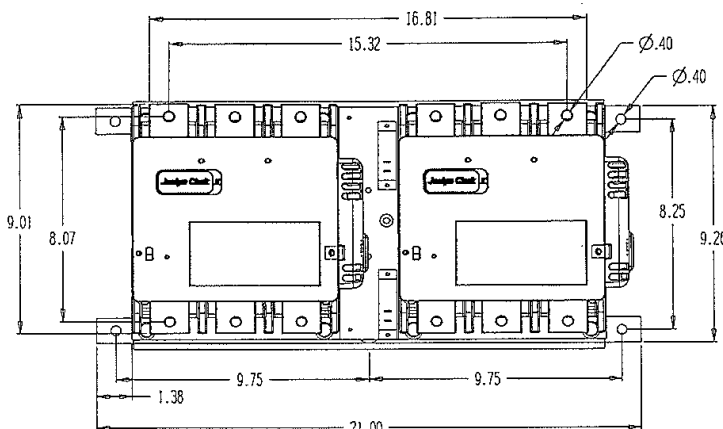

600Volt Nema Size 5 270A Mechanically Interlocked Pair Unwired 3 Pole Nema ICS-2 UL508 CSA 22.2

Rating Nema Size 5	Maximum Horsepower/KW Rating 3 Phase HP/KW				Open Type
600V	200V	230V	460V	575V	Catalog #
HP/KW	75/56	100/75	200/150	200/150	CV31U030506-* -43

1000Volt 400AMP Mechanically Interlocked Pair Unwired 3 Pole IEC 947-4-1 UL508 CSA 22.2

Rating 400A	Maximum Horsepower/KW Rating 3 Phase HP/KW						Open Type
1000V	200/208V	220/240V	380/415V	460V	575/600V	660-690V	Catalog #
HP/KW	100/75	150/112	250/187	300/220	400/300	450/336	CV31U034A06-* -43

1500V 400AMP Mechanically Interlocked Pair Unwired 3 Pole IEC 947-4-1 (1000V) UL508 (1500V) CSA 22.2 (1500V)

Rating 400A	Maximum Horsepower/KW Rating 3 Phase HP/KW								Open Type
1500V	200/208V	220/240V	415/440V	460V	575/600V	660-690V	1000V	1500V	Catalog #
HP/KW	100/75	150/112	250/187	300/220	400/300	500/370	700/520	850/650	CV31U034A15-* -43
Nema V320	100/70	125/95	200/150	300/220	300/220	-	500/370	900/670	CV31U03V15-* -43

Replacement Parts (Discount Schedule JC80)

Description	Catalog #
Interrupter Phase Assembly	A77-460880A-1
Coil 110/120V 50/60 HZ	A77-460930A-1
Coil 220/240V 50/60 HZ	A77-460930A-2
Coil 380/415V 50/60 HZ	A77-460930A-3
Coil 440/480V 50/60 HZ	A77-460930A-4
Coil 125V DC	A77-460930A-5
Coil 250V DC	A77-460930A-6
Control PAK 110/120 50/60 HZ	A77-460916A-4
Control PAK 220/240 50/60 HZ	A77-460916A-5
Control PAK 380-415V 50/60 HZ 440-480V 50/60 HZ	A77-460916A-6
Aux. Contact Kit 2N/O 1N/C +1 N/C Late Break	AK Std.

Options (Discount Schedule JC11) Field Kits

Description	Catalog #
Lug Kit 3 Per Kit #4-500 mcm	KVC5-1
Lug Kit 3 Per Kit (2) #6-300 mcm	KVC5-2
Aux Contact Kit 2N/O 2N/C 10A 600VAC	AK1
Aux. Contact Kit 2N/O 2N/C 10MA 5VDC	AK3

Plug Stop Jogging Duty

Nema Size	200V	230V	400V	460V	575V
5	50HP	60HP	100HP	120HP	-
V320	75HP	100HP	150HP	175HP	200HP

Ordering Information

- Use complete catalog number when ordering.
- Replace the (*) with the suffix from the coil table.
- Engineering Data page A13.
- Renewal Parts page A9.

* Coil Table

Voltage Suffix	
120 AC	-76
240 AC	-26
380 AC	-38
460 AC	-46
125V DC	-125
250V DC	-250

USAVAC - LOW VOLTAGE

AC Mechanically Interlocked Vacuum Contactors Wired

A

- CE
- NEMA Size 5 & V320
- IEC 400A
- Three Ratings
- One Small Size
- Use for Reversers, Reduced Voltage Auto Transformer Starters, Wye-Delta, 2 speed single winding, starter applications

600Volt Nema Size 5 270A Contactor Mechanically Interlocked Pair Wired 3 Pole Nema ICS-2 UL508 CSA 22.2

Rating Nema Size 5	Maximum Horsepower/KW Rating 3 Phase HP/KW				Open Type
600V	200V	230V	460V	575V	Catalog #
HP/KW	75/56	100/75	200/150	200/150	CV31U030506-*

1000Volt 400AMP Contactor Mechanically Interlocked Pair Wired 3 Pole IEC 947-4-1 UL508 CSA 22.2

Rating 400A	Maximum Horsepower/KW Rating 3 Phase HP/KW						Open Type
1000V	200/208V	220/240V	380/415V	460V	575/600V	660-690V	Catalog #
HP/KW	100/75	150/112	250/187	300/220	400/300	450/336	CV31U034A06-*

1500V 400AMP Contactor Mechanically Interlocked Pair Wired 3 Pole IEC 947-4-1 (1000V) UL508 (1500V) CSA 22.2 (1500V)

Rating 400A	Maximum Horsepower/KW Rating 3 Phase HP/KW								Open Type
1500V	200/208V	220/240V	415/440V	460V	575/600V	660-690	V1000V	1500V	Catalog #
HP/KW	100/75	150/112	250/187	300/220	400/300	450/336	500/370	800/520	CV31U034A06-*
Nema V320	100/75	125/95	200/150	300/220	300/220	300/220	500/370	800/520	CV31U034A06-*

Options (Discount Schedule JC11) Field Kits

Description	Catalog #
Lug Kit 3 Per Kit #4-500 mcm	KVC5-1
Lug Kit 3 Per Kit (2) #6-300 mcm	KVC5-2
Aux Contact Kit 2N/O 2N/C 10A 600VAC	AK1
Aux. Contact Kit 2N/O 2N/C 10MA 5VDC	AK3

Plug Stop Jogging Duty

Nema Size	575V	200V	230V	400V	460V
5	50HP	60HP	100HP	120HP	-
V320	75HP	100HP	150HP	175HP	200HP

Ordering Information

- Use complete catalog number when ordering. Replace the (*) with the suffix from the coil table.
- Engineering Data page A13.
- Renewal Parts page A8.

* Coil Table

Voltage	Suffix
120 AC	-76
240 AC	-26
380 AC	-38
460 AC	-46
125V DC	-125
250V DC	-250

Replacement Parts (Discount Schedule JC80)

Description	Catalog #
Interrupter Phase Assembly	A77-460880A-1
Coil 110/120V 50/60 HZ	A77-460930A-1
Coil 220/240V 50/60 HZ	A77-460930A-2
Coil 380/415V 50/60 HZ	A77-460930A-3
Coil 440/480V 50/60 HZ	A77-460930A-4
Coil 125V DC	A77-460930A-5
Coil 250V DC	A77-460930A-6
Control PAK 110/120 50/60 HZ	A77-460916A-4
Control PAK 220/240 50/60 HZ	A77-460916A-5
Control PAK 380-415V 50/60 HZ 440-480V 50/60 HZ	A77-460916A-6
Aux. Contact Kit 2N/O 1N/C +1 N/C Late Break	AK Std.

WIRED CONTACTORS NOT AVAILABLE, SEE PAGE A9 FOR MECHANICALLY INTERLOCKED UNITS OR CALL FACTORY

USAVAC - LOW VOLTAGE AC Vacuum Starters

A

**CV Series
NEMA Size 5 V320
IEC 400A**

- UL listed to 1500V
- CSA Certified to 1500V
- CE
- Three Ratings
- One Small Size



600V NEMA Size 5 270A

600Volt Nema Size 5 270A Starter 3 Pole Nema ICS-2 UL508 CSA 22.2

Rating Nema Size 5	Maximum Horsepower/KW Rating 3 Phase HP/ KW				Open Type
	600V	200/208V	230V	460V	575V
HP/KW	75/56	100/75	200/150	200/150	CV13U030506-*

1000Volt 400AMP Starter 3 Pole IEC 947-4-1 UL508 CSA 22.2

Rating 400A	Maximum Horsepower/KW Rating 3 Phase HP/KW						Open Type
	1000V	200/208V	220/240V	400V	460V	575/600V	660-690V
HP/KW	100/75	150/112	250/187	300/220	400/300	450/336	CV13U034A06-*

1500V 400AMP Starter 3 Pole IEC 947-4-1 (1000V) UL508 (1500V) CSA 22.2 (1500V)

Rating 400A	Maximum Horsepower/KW Rating 3 Phase HP/KW								Open Type
	1500V	200/208V	220/240V	380/415V	460V	575/600V	660-690V	1000V	1500V
HP/KW	100/75	150/112	250/187	300/220	400/300	500/370	700/520	850/650	CV13U034A15-*
Nema V320	100/75	150/112	250/187	300/220	300/220	-	500/370	900/670	CV13U033V15-*

Replacement Parts (Discount Schedule JC80)

Description	Catalog #
Interrupter Phase Assembly	A77-460880A-1
Coil 110/120V 50/60 HZ	A77-460930A-1
Coil 220/240V 50/60 HZ	A77-460930A-2
Coil 380/415V 50/60 HZ	A77-460930A-3
Coil 440/480V 50/60 HZ	A77-460930A-4
Coil 125V DC	A77-460930A-5
Coil 250V DC	A77-460930A-6
Control PAK 110/120 50/60 HZ	A77-460916A-4
Control PAK 220/240 50/60 HZ	A77-460916A-5
Control PAK 380-415V 50/60 HZ 440-480V 50/60 HZ	A77-460916A-6
Aux. Contact Kit 2N/O 1N/C +1 N/C Late Break	AK Std.

Options (Discount Schedule JC11) Field Kits

Description	Catalog #
Lug Kit 3 Per Kit #4-500 mcm	KVC5-1
Lug Kit 3 Per Kit (2) #6-300 mcm	KVC5-2
Aux Contact Kit 2N/O 2N/C 10A 600VAC	AK1
Aux. Contact Kit 2N/O 2N/C 10MA 5VDC	AK3

Ordering Information

- Use complete catalog number when ordering. Replace the (*) with the suffix from the coil table.
- Engineering Data page A13.
- Renewal Parts page A11

* Coil Table

	Voltage Suffix
120 AC	-76
240 AC	-26
380 AC	-38
460 AC	-46
125V DC	-125
250V DC	-250

USAVAC - LOW VOLTAGE

AC Vacuum Reversing Starters

A

3 Pole Nema ICS-2 UL508 CSA 22.2 Size 5 Reversing Starter 600V 270 AMP

Rating Nema Size 5	Maximum Horsepower/KW Rating 3 Phase HP/KW				Open Type
600V	200V	230V	460V	575V	Catalog #
HP/KW	75/56	100/75	200/150	200/150	CV30U030506-*

- NEMA Size 5 & V 320
- IEC 400A
- Three Ratings
- One Small Size
- Use for Reversers, Reduced Voltage Auto Transformer Starters, Wye-Delta, 2 speed single winding, starter applications

3 Pole IEC 947-4-4 UL508 CSA 22.2 Reversing Starter 660V 400 AMP

Rating 400A	Maximum Horsepower/KW Rating 3 Phase HP/KW						Open Type
1000V	200/208V	220/240V	380/415V	460V	575/600V	660-690V	Catalog #
HP/KW	100/75	150/112	250/187	300/220	400/300	450/336	CV30U034A06-*

WIRED CONTACTORS

3 Pole IEC 947-4-1 (1000V) UL508 (1500V) CSA 22.2 (1500V) 400A

Rating 400A Nema V320	Maximum Horsepower/KW Rating 3 Phase HP/KW								Open Type
1500V	200/208V	220/240V	415/440V	460V	575/600V	660-690V	1000V	1500V	Catalog #
HP/KW	100/75	150/112	250/187	300/220	400/300	500/370	700/520	850/650	CV30U034A15-*
Nema V320	100/70	125/95	200/150	300/220	400/220	-	500/300	800/670	CV30U033V15-*

**NOT AVAILABLE,
SEE PAGE A9 FOR**

MECHANICALLY INTERLOCKED

Options Discount Schedule JC11 Field Kits

Description	Catalog #
Lug Kit 3 Per Kit #4-500 mm	KVCS-1
Lug Kit 3 Per Kit (2) #6-800 mm	KVCS-2
Aux Contact Kit 2N/O 2N/C 10A 600VAC	AK1
Aux. Contact Kit 2N/O 2N/C 10MA 5VDC	AK3

UNITS OR CALL FACTORY

Plug Stop Jogging Duty

Nema Size	200V	230V	400V	460V	575V
5	50HP	60HP	100HP	120HP	-
V320	75HP	100HP	150HP	175HP	200HP

Ordering Information

* Coil Table

- Use complete catalog number when ordering. Replace the (*) with the suffix from the coil table.
- Engineering Data page A13.
- Renewal Parts page A12.

Voltage Suffix	
120 AC	-76
240 AC	-26
380 AC	-38
460 AC	-46
125V DC	-125
250V DC	-250

Replacement Parts (Discount Schedule JC80)

Description	Catalog #
Interrupter Phase Assembly	A77-460880A-1
Coil 110/120V 50/60 HZ	A77-460930A-1
Coil 220/240V 50/60 HZ	A77-460930A-2
Coil 380/415V 50/60 HZ	A77-460930A-3
Coil 440/480V 50/60 HZ	A77-460930A-4
Coil 125V DC	A77-460930A-5
Coil 250V DC	A77-460930A-6
Control PAK 110/120 50/60 HZ	A77-460916A-4
Control PAK 220/240 50/60 HZ	A77-460916A-5
Control PAK 380-415V 50/60 HZ	A77-460916A-6
440-480V 50/60 HZ	
Aux. Contact Kit 2N/O 1N/C +1 N/C Late Break	AK Std.

USAVAC LOW VOLTAGE AC VACUUM CONTACTORS & STARTERS

Engineering Data

Technical Specifications CV Series

Description	NEMA Size 5 600V	400 Amp 1000V	400 Amp 1500V
Cat #	CV77U030506-*	CV77U034A06-*	CV77U034A15-*
Standard	NEMA ICS-2 UL508 CSA22.2	IEC 947-4-1 1000V UL508 CSA22.2	IEC 947-4-1 1000V NEMA ICS-2.9 1500V UL508 CSA22.2 1500V
Power Ratings Enclosed			
Insul. & Operating Volt	600 Volts	1000 Volts	1500 Volts
Rated Oper. AC1	270 Amps	400 Amps	400 Amps
Rated Oper. AC3	200 HP 460/575V	500 HP-370KW-660V	850 HP-650KW-1500V
Rated Oper. AC4	120 HP 460/575V	300 HP-260KW-660V	650 HP-570KW-1500V
Rated Frequency	50 - 400 Hz		
Making Current	4000 Amps		
Breaking Current	3200 Amps		
Dielectric Strength	6Kv - 1 Min. Interrupter		
Interrupting Current	4.6 KA		
Short Time Current 1 Sec.	7000 A		
Short Time Current 10 Sec	3200 A		
Mechanical Life	1.2 X 10 ⁶		
Elect. Life AC3 Duty	1 X 10 ⁶		
Switching Frequency	v600/ Hour 1 Every 6 Sec		
Withstand Current	18KA 50 MS		
Chop Current Max	0.9 A		
Operating Range	-15% + 10% - over Range Voltage		
Inrush Power VA	1100VA 120 ms Duration		
Holding Power VA	10-12 VA		
Opening Time MS	160ms		
Closing Time MS	20-40ms		
Pick-Up Voltage	80% Cold 85% Hot or less		
Drop-Out Voltage	70% or less		
Recommended CPT	500VA Machine Tool Transformer 5% Regulation at 20%pf		
Applications Ratings			
Mounting Installation	All Planes Contactor Only		
Altitude	6600 ft. 2000 Meters		
Ambient Storage	-65°F (-54°C) +160°F (71°C)		
Operating	-40°F (-40°C) +122°F (50°C)		
Vibration / Shock	40Hz - 2G. / 30G.		
Weight	26 lbs. 11.8 Kg.		

Power Rating

Motor HP/KW AC3		
Voltage	270A	400A
208	75/56	100/75
220/240	100/75	150/112
380/415	----	250/187
460	200/150	300/220
575/600	200/150	400/300
660/690	----	450/336
1000	----	700/520
1500	----	850/650
Three Phase Transformer Load KVA		
Voltage	270A	400A
208	108	144
220/240	114	110
380/400	198	270
415/440	216	304
460/500	238	346
575/600	260	414
660	342	450
1000	520	692
1500	780	1038
Three Phase Capacitor Load KVAR		
Voltage	270A	400A
208	80	108
220/240	86	124
380/400	148	208
415/440	162	228
460	180	254
575/600	230	312
1000	390	520
1500	584	780

Options

Lug Kit 2 #6 300mcm 3per Auxiliary Contact Kits	Cat.# KVC5-2
2NO. 2NC 600V. 10A ac.	Cat.# AK1
2NO. 2NC 5V.10mA dc.	Cat.# AK3

Only 1 Kit can be added for total of 3 N/O 3 N/C contacts

Coils

Description	Hz.	Cat.Suffix
110/120V	50/60Hz.	-76
220/240V	50/60Hz.	-26
380/415V	50/60Hz.	-38
440/480V	50/60Hz.	-46
125V dc		-125
250V dc		-250

Dimensions

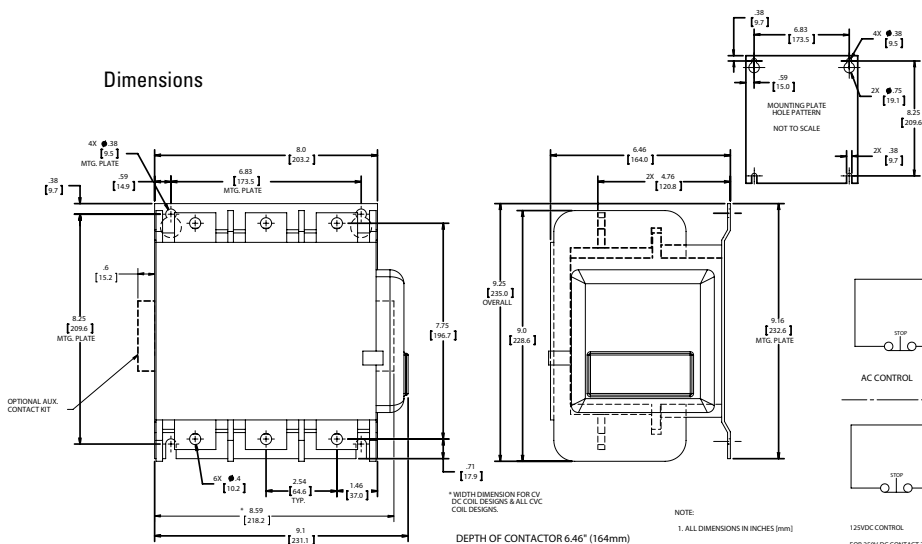

For 250V dc contact 21/22 is Late Break N/C in series with 'm' late break

DEPTH OF CONTACTOR 6.46" (164mm)

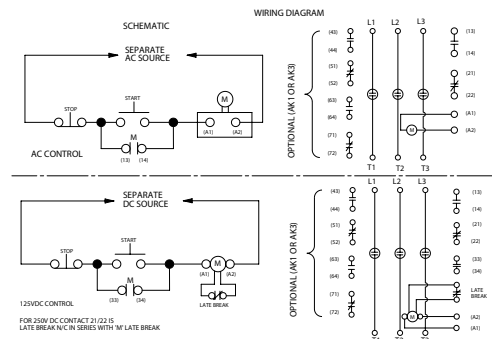

USAVAC - LOW VOLTAGE

AC Vacuum Contactors

A

CV Series
NEMA Size 6
NEMA V600
IEC 600A

- UL listed to 1500V
- CSA Certified to 1500V
- CE
- Three Ratings
- One Small Size



600V NEMA Size 6 540A



1000V 600A

600Volt Nema Size 6 540A Contactor 3 Pole Nema ICS-2 UL508 CSA 22.2

Rating Nema Size 6	Maximum Horsepower/KW Rating 3 Phase HP/KW				Open Type
	200/208V	250V	460V	575V	
600V	200/208V	250V	460V	575V	Catalog #
HP/KW	150/112	200/150	400/300	400/300	CV77U030606-*

1000Volt 600AMP Contactor 3 Pole IEC 947-4-1 UL508 CSA 22.2

Rating 600A 1000V	Maximum Horsepower/KW Rating 3 Phase HP/KW						Open Type
	200/208V	220/240V	400V	460V	575/600V	660-690V	
1000V	200/208V	220/240V	400V	460V	575/600V	660-690V	Catalog #
HP/KW	200/150	200/150	250/187	400/300	600/450	650/485	CV77U036A06-*

1500V 600AMP Contactor 3 Pole IEC 947-4-1 (1000V) UL508 (1500V) CSA 22.2 (1500V)

Rating 600A Nema V600	Maximum Horsepower/KW Rating 3 Phase HP/KW								Open Type
	200/208V	220/240V	400V	460V	575/600V	660-690V	1000V	1500V	
1500V	200/208V	220/240V	400V	460V	575/600V	660-690V	1000V	1500V	Catalog #
HP/KW	200/150	200/150	250/187	400/300	600/450	650/485	1000/750	1200/900	CV77U036A15-*
Nema V600	200/150	200/150	375/280	500/350	600/470	-	1100/820	1600/1200	CV77U036V15-*

Options (Discount Schedule JC11) Field Kits

Description	Catalog #
Wire Size (2) #2-600 mcm 3 lugs per kit	KVC6-2
Aux Contact Kit 2N/O 2N/C 10A 600VAC	AK1
Aux. Contact Kit 2N/O 2N/C 10MA 5VDC	AK3

Ordering Information

* Coil Table

- Use complete catalog number when ordering. Replace the (*) with the suffix from the coil table.
- Engineering Data page A19.
- Renewal Parts page A14.

Voltage Suffix	
120 AC	-76
240 AC	-26
380 AC	-38
460 AC	-46
125V DC	-125
250V DC	-250

Replacement Parts (Discount Schedule JC80)

Description	Catalog #
Interrupter Phase Assembly	A77-460880A-2
Coil 110/120V 50/60 HZ	A77-460930A-1
Coil 220/240V 50/60 HZ	A77-460930A-2
Coil 380/415V 50/60 HZ	A77-460930A-3
Coil 440/480V 50/60 HZ	A77-460930A-4
Coil 125V DC	A77-460930A-7
Coil 250V DC	A77-460930A-8
Control PAK 110/120 50/60 HZ	A77-460916A-4
Control PAK 220/240 50/60 HZ	A77-460916A-5
Control PAK 380-415V 50/60 HZ	A77-460916A-6
440-480V 50/60 HZ	
Aux. Contact Kit 2N/O 1N/C +1 N/C Late Break	AK Std.

USAVAC - LOW VOLTAGE

AC Mechanically Interlocked Vacuum Contactors Unwired

A

- CE
- NEMA Size 6 & V600
- IEC 600A
- Three Ratings
- One Small Size
- Use for Reversing, Reduced Voltage Auto Transformer, Wye-Delta, 2 speed single winding, or 2 speed 2 winding applications

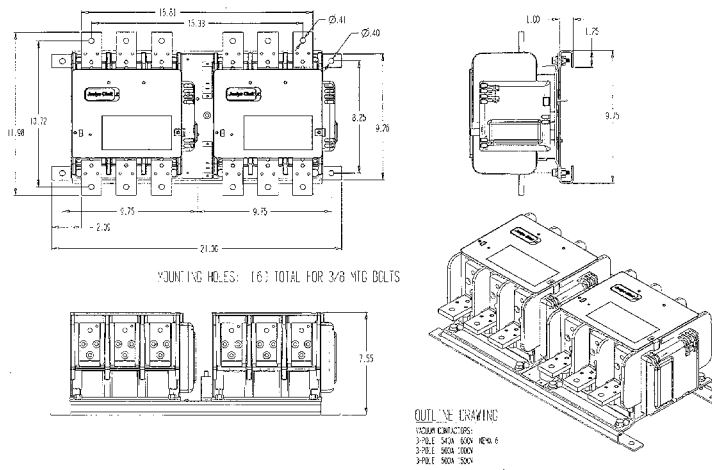

3 Pole Nema Rated ICS-2 UL508 CSA 22.2 Mechanically Interlocked Pair Unwired 600V Size 6 540 AMP

Rating Nema Size 6	Maximum Horsepower/KW Rating 3 Phase HP/KW				Open Type
	200/208V	250V	460V	575V	
600V	200/208V	250V	460V	575V	Catalog #
HP/KW	150/112	200/150	400/300	400/300	CV31U030606-* -43

3 Pole IEC 947-4-1 UL508 CSA 22.2 Mechanically Interlocked Pair Unwired 1000 Volt 600 AMP

Rating 600A 1000V	Maximum Horsepower/KW Rating 3 Phase HP/KW						Open Type
1000V	200/208V	220/240V	400V	460V	575/600V	660-690V	
HP/KW	200/150	200/150	250/187	400/300	600/450	650/485	CV31U036A06-* -43

3 Pole IEC 947-4-1 (1000V) UL508 (1500V) CSA 22.2 (1500V) Mechanically Interlocked Pair Unwired 1.5 KV 600AMP

Rating 600A Nema V600	Maximum Horsepower/KW Rating 3 Phase HP/KW								Open Type
1500V	200/208V	220/240V	400V	460V	575/600V	660-690V	1000V	1500V	
HP/KW	200/150	200/150	250/187	400/300	600/450	650/485	1000/750	1200/900	CV31U036A15-* -43
Nema V600	200/150	200/150	375/280	500/350	600/470	-	1100/820	1600/1200	CV31U036V15-* -43

Replacement Parts (Discount Schedule JC80)

Description	Catalog #
Interrupter Phase Assembly	A77-460880A-2
Coil 110/120V 50/60 HZ	A77-460930A-1
Coil 220/240V 50/60 HZ	A77-460930A-2
Coil 380/415V 50/60 HZ	A77-460930A-3
Coil 440/480V 50/60 HZ	A77-460930A-4
Coil 125V DC	A77-460930A-7
Coil 250V DC	A77-460930A-8
Control PAK 110/120 50/60 HZ	A77-460916A-4
Control PAK 220/240 50/60 HZ	A77-460916A-5
Control PAK 380-415V 50/60 HZ 440-480V 50/60 HZ	A77-460916A-6
Aux. Contact Kit 2N/O 1N/C +1 N/C Late Break	AK Std.

Options (Discount Schedule JC11) Field Kits

Description	Catalog #
Wire Size (2) #2-600 mcm 3 lugs per kit	KVC6-2
Aux Contact Kit 2N/O 2N/C 10A 600VAC	AK1
Aux. Contact Kit 2N/O 2N/C 10MA 5VDC	AK3

Plug Stop Jogging Duty

Nema Size	200V	230V	400V	460V	575V
6	100HP	120HP	200HP	240HP	-
V600	150HP	150HP	300HP	375HP	450HP

Ordering Information

- Use complete catalog number when ordering. Replace the (*) with the suffix from the coil table.
- Engineering Data page A19.
- Renewal Parts page A15.

* Coil Table

Voltage Suffix	
120 AC	-76
240 AC	-26
380 AC	-38
460 AC	-46
125V DC	-125
250V DC	-250

USAVAC - LOW VOLTAGE

AC Mechanically Interlocked Vacuum Contactors Wired

A

CV Series
NEMA Size 6
IEC 600A

- Three Ratings
- One Small Size
- Use for Reversing, Reduced Voltage Auto Transformer, Wye-Delta, 2 speed single winding, or 2 speed two winding applications

3 Pole Nema Rated ICS-2 UL508 CSA 22.2 Mechanically Interlocked Pair Wired 600V Size 6 540 AMP

Rating Nema Size 6	Maximum Horsepower/KW Rating 3 Phase HP/KW				Open Type Catalog #
	200/208V	250V	460V	575V	
600V	200/208V	250V	460V	575V	Catalog #
HP/KW	150/112	200/150	400/300	400/300	CV31U030606-*

3 Pole IEC 947-4-1 UL508 CSA 22.2 Mechanically Interlocked Pair Wired 1000 Volt 600 AMP

Rating 600A V600	Maximum Horsepower/KW Rating 3 Phase HP/KW						Open Type Catalog #
	200/208V	220/240V	400V	460V	575/600V	660-690V	
1000V	200/208V	220/240V	400V	460V	575/600V	660-690V	Catalog #
HP/KW	200/150	200/150	250/187	400/300	600/450	650/485	CV31U036006

3 Pole IEC 947-4-1 (1000V) UL508 (1500V) CSA 22.2 (1500V) Mechanically Interlocked Pair Wired 1.5 KV 600 AMP

Rating 600A Nema 1000V	Maximum Horsepower/KW Rating 3 Phase HP/KW								Open Type Catalog #
	200/208V	220/240V	400V	460V	575/600V	660-690V	1100V	1500V	
1500V	200/208V	220/240V	400V	460V	575/600V	660-690V	1100V	1500V	Catalog #
HP/KW	200/150	200/150	250/187	400/300	600/450	650/485	1100/750	1600/900	CV31U036V15-*
Nema V600	200/150	200/150	375/280	500/350	600/470	-	1100/820	1600/1200	CV31U036V15-*

Options (Discount Schedule JC11) Field Kits

Description	Catalog #
Wire Size (2) #2-600 mcm 3 lugs per	KVC6-2
Aux Contact Kit 2N/O 2N/C 10A 600VAC	AK1
Aux. Contact Kit 2N/O 2N/C 10MA 5VDC	AK3

Plug Stop Jogging Duty

Nema Size	200V	230V	400V	460V	575V
6	100HP	120HP	200HP	240HP	-
V600	150HP	150HP	300HP	375HP	450HP

Ordering Information

- Use complete catalog number when ordering. Replace the (*) with the suffix from the coil table.
- Engineering Data page A19.
- Renewal Parts page A16.

* Coil Table

Voltage	Suffix
120 AC	-76
240 AC	-26
380 AC	-38
460 AC	-46
125V DC	-125
250V DC	-250

Replacement Parts (Discount Schedule JC80)

Description	Catalog #
Interrupter Phase Assembly	A77-460880A-2
Coil 110/120V 50/60 HZ	A77-460930A-1
Coil 220/240V 50/60 HZ	A77-460930A-2
Coil 380/415V 50/60 HZ	A77-460930A-3
Coil 440/480V 50/60 HZ	A77-460930A-4
Coil 125V DC	A77-460930A-7
Coil 250V DC	A77-460930A-8
Control PAK 110/120 50/60 HZ	A77-460916A-4
Control PAK 220/240 50/60 HZ	A77-460916A-5
Control PAK 380-415V 50/60 HZ 440-480V 50/60 HZ	A77-460916A-6
Aux. Contact Kit 2N/O 1N/C +1 N/C Late Break	AK Std.

**WIRED CONTACTORS
NOT AVAILABLE,
SEE PAGE A15 FOR
MECHANICALLY INTERLOCKED
UNITS OR CALL FACTORY**

CV Series
NEMA Size 6
IEC 600A

- Three Ratings
- One Small Size



600V NEMA Size 5 270A

600Volt Nema Size 6 540A Starter 3 Pole Nema ICS-2 UL508 CSA 22.2

Rating Nema Size 6	Maximum Horsepower/KW Rating 3 Phase HP/KW				Open Type
	600V	200/208V	2500V	460V	
HP/KW	150/112	200/150	400/300	400/300	CV13U030606-*

1000Volt 600AMP Contactor 3 Pole IEC 947-4-1 UL508 CSA 22.2

Rating 600A 1000V	Maximum Horsepower/KW Rating 3 Phase HP/KW						Open Type
	1000V	200/208V	220/240V	400V	460V	575/600V	
HP/KW	200/150	200/150	250/187	400/300	600/450	650/485	CV13U036A06-*

1500 Volt 600 AMP Starter 3 Pole ICS 2-9 IEC 947-4-1 (1000V) UL508 (1500V) CSA 22.2 (1500V)

Rating 600A Nema V600	Maximum Horsepower/KW Rating 3 Phase HP/KW								Open Type
	1500V	200/208V	220/240V	400V	460V	575/600V	660-690V	1000V	
HP/KW	200/150	200/150	250/187	400/300	600/450	650-485	1000/750	1200/900	CV13U036A15-*
Nema V600	200/150	200/150	375/280	500/350	600/470		1100/820	1600/1200	CV13U036V15-*

Replacement Parts (Discount Schedule JC80)

Description	Catalog #
Interrupter Phase Assembly	A77-460880A-2
Coil 110/120V 50/60 HZ	A77-460930A-1
Coil 220/240V 50/60 HZ	A77-460930A-2
Coil 380/415V 50/60 HZ	A77-460930A-3
Coil 440/480V 50/60 HZ	A77-460930A-4
Coil 125V DC	A77-460930A-7
Coil 250V DC	A77-460930A-8
Control PAK 110/120 50/60 HZ	A77-460916A-4
Control PAK 220/240 50/60 HZ	A77-460916A-5
Control PAK 380-415V 50/60 HZ 440-480V 50/60 HZ	A77-460916A-6
Aux. Contact Kit 2N/O 1N/C +1 N/C Late Break	AK Std.

Options (Discount Schedule JC11) Field Kits

Description	Catalog #
Wire Size (2) #2-600 mcm 3 Lugs Per Kit	KVC6-2
Aux Contact Kit 2N/O 2N/C 10A 600VAC	AK1
Aux. Contact Kit 2N/O 2N/C 10MA 5VDC	AK3

Ordering Information

- Use complete catalog number when ordering. Replace the (*) with the suffix from the coil table.
- Engineering Data page A19.
- Renewal Parts page A17.

*** Coil Table**

Voltage Suffix	
120 AC	-76
240 AC	-26
380 AC	-38
460 AC	-46
125V DC	-125
250V DC	-250

USAVAC - LOW VOLTAGE

AC Reversing Starters

A

CV Series
NEMA Size 6
IEC 600A

- Three Ratings
- One Small Size
- Use on Reversers Reduced Voltage Auto Transformers, Wye-Delta & 2 speed single or double winding starter applications.

600Volt Nema Size 6 540A Starter 3 Pole Nema ICS-2 UL508 CSA 22.2

Rating Nema Size 6	Maximum Horsepower/KW Rating 3 Phase HP/KW				Open Type
600V	200/208V	250V	460V	575V	Catalog #
HP/KW	150/112	200/150	400/300	400/200	CV30U030606-*

1000Volt 600A Reversing Starter 3 Pole IEC 947-4-1 UL508 CSA 22.2

Rating 600A	Maximum Horsepower/KW Rating 3 Phase HP/KW							Open Type
660V	200/208V	220/240V	380/400V	415/440V	460V	575/600V	660-690V	Catalog #
HP/KW	200/150	200/150	250/180	400/300	400/300	600/450	650/485	CV30U066A06

1500 Volt 600 AMP Starter 3 Pole ICS-2 IEC 947-4-1 (1000V) UL508 (1500V) CSA 22.2 (1500V)

Rating 600A	Maximum Horsepower/KW Rating 3 Phase HP/KW								Open Type
1500V	200/208V	220/240V	400V	460V	575/600V	660-690V	1000V	1500V	Catalog #
HP/KW	200/150	200/150	375/280	400/300	600/450	650/485	900/750	1200/900	CV60U036A
Nema V600	200/150	200/150	375/280	500/350	600/470	-	1100/820	1600/1200	CV30U036V15-*

Options (Discount Schedule JC11) Field Kits

Description	Catalog #
Wire Size (2) #2-600 mcm 3 lugs per kit	KVC6-2
Aux Contact Kit 2N/O 2N/C 10A 600VAC	AK1
Aux. Contact Kit 2N/O 2N/C 10MA 5VDC	AK3

Plug Stop Jogging Duty

Nema Size	200V	230V	400V	460V	575V
6	100HP	120HP	200HP	240HP	-
V600	150HP	150HP	300HP	375HP	450HP

Ordering Information

- Use complete catalog number when ordering.
- Replace the (*) with the suffix from the coil table.
- Engineering Data page A19.
- Renewal Parts page A18.

* Coil Table

Voltage Suffix	
120 AC	-76
240 AC	-26
380 AC	-38
460 AC	-46
125V DC	-125
250V DC	-250

Replacement Parts (Discount Schedule JC80)

Description	Catalog #
Interrupter Phase Assembly	A77-460880A-2
Coil 110/120V 50/60 HZ	A77-460930A-1
Coil 220/240V 50/60 HZ	A77-460930A-2
Coil 380/415V 50/60 HZ	A77-460930A-3
Coil 440/480V 50/60 HZ	A77-460930A-4
Coil 125V DC	A77-460930A-7
Coil 250V DC	A77-460930A-8
Control PAK 110/120 50/60 HZ	A77-460916A-4
Control PAK 220/240 50/60 HZ	A77-460916A-5
Control PAK 380-415V 50/60 HZ	A77-460916A-6
440-480V 50/60 HZ	
Aux. Contact Kit 2N/O 1N/C +1 N/C Late Break	AK Std.

**WIRED CONTACTORS
NOT AVAILABLE,
SEE PAGE A15 FOR
MECHANICALLY INTERLOCKED
UNITS OR CALL FACTORY**

USAVAC - LOW VOLTAGE

AC Vacuum Contactors

A

- UL Listed to 1500V ⁵
- CSA Certified to 1500V ⁵
- UL/CSA recognized to 3600V ⁶
- Electrically Held AC or DC Coils



3 Pole, 320A, 1500V

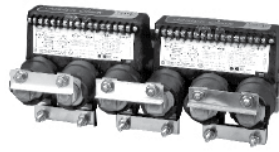

3 Pole, 600A, 1500V



3 Pole, 700A, 600V

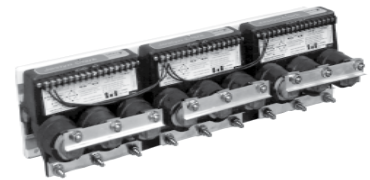

3 Pole, 1000A, 1500V

Contactors 200V-1500V - Bulletin 7707

Ampere Rating	Maximum Horsepower Ratings - 3 Phase							Size	Open Type Catalog No.
	200/208V	230V	380V	460V	575V	1000V	1500V		
3 Pole									
160 ³	50	60	100	125	150	300	420	4	VC77U03415 -*
320 ³	100	125	200	250	300	600	830	5	VC77U03515 -*
600 ¹	200	200	375	500	575	1200	1600	6	VC77U03615 -*
700 ⁶	225	300	500	550	700	-----	-----	---	VC77U037A06 -*
1000 ^{1,2}	-----	-----	-----	-----	-----	-----	-----	---	SVC77U031015 -*
2 Pole									
160	-----	-----	-----	-----	-----	-----	-----	4	VC77U02415 -*
320	-----	-----	-----	-----	-----	-----	-----	5	VC77U02515 -*
600 ¹	-----	-----	-----	-----	-----	-----	-----	6	VC77U02615 -*
1000 ¹	-----	-----	-----	-----	-----	-----	-----	---	SVC77U021015 -*

Contactors 1501V-3600V - Bulletin 7707

Ampere Rating	Maximum Horsepower Ratings - 3 Phase		Open Type Catalog No.
	2300V	3300V	
3 Pole			
160 ⁴	600	1	VC77U03436 -*
320 ⁴	1250	1	VC77U03536 -*
600 ¹⁻³	2400	1	VC77U03636 -*
1000 ¹⁻³	-----	---	SVC77U031036
2 Pole			
160	-----	-----	VC77U02436 -*
320	-----	-----	SVC77U021036 -*

Notes:

1. Two 320 ampere contactors connected in parallel for 600A, three in parallel for 1000A.
2. Motor applications limited to 1000 ampere continuous and LRC 6KA maximum.
3. Terminal boots provided on center phase.
4. Terminal boots provided on all phases.
5. 160, 320, 600A 3 pole contactors UL listed and CSA certified.
6. UR recognition 600V

- Mechanically Interlocked Contactors on page A22 and A23 should be used if short circuit current can flow when switching between two or more contactors.
- For KW Rating Multiply HP Ratings by .746 (example: 100HP x .746 = 75KW)

Ordering Information

- Use complete catalog number when ordering. Replace the (*) with the suffix from the coil table.
- Engineering Data page A30.
- Renewal Parts page A36.

* Coil Table

Voltage Suffix	
120 AC	-76
240 AC	-26
380 AC	-38
460 AC	-46
125V DC	-125
250V DC	-250

USAVAC - LOW & MEDIUM VOLTAGE AC Latched Vacuum Contactors

A

- UL Listed to 1500V ³
- CSA Certified to 1500V ³
- UL/CSA to 3600V ⁴
- Mechanically Latched AC & DC Close And Trip Coils



3 Pole, 320A, 1500V



3 Pole, 600A, 1500V



3 Pole, 700A, 600V

Contactors 200V-1500V - Bulletin 7707

Ampere Rating	Maximum Horsepower Ratings - 3 Phase							Size	Type Catalog No.
	200/208V	230V	380V	460V	575V	1000V	1500V		
3 Pole									
160 ¹	50	60	100	125	150	300	420	4	VCL77U03415 -*
320 ¹	100	125	200	250	300	600	830	5	VCL77U03515 -*
600 ¹	200	200	375	500	575	1200	1600	6	VCL77U03615 -*
700 ⁴	225	300	500	550	700	-----	-----		VCL77U037A06 -*
2 Pole									
160	-----	-----	-----	-----	-----	-----	-----	4	VCL77U02415 -*
320	-----	-----	-----	-----	-----	-----	-----	5	VCL77U02515 -*

Contactors 1501V-3600V - Bulletin 7707

Ampere Rating	Maximum Horsepower Ratings - 3 Phase		Open Type Catalog No.
	2300V	3300V	
3 Pole			
160 ²	600	960	VCL77U03436 -*
320 ²	1250	1920	VCL77U03536 -*
2 Pole			
160	-----	-----	VCL77U02436 -*
320	-----	-----	VCL77U02536 -*

Notes:

1. Terminal boots provided on center phase.
2. Terminal boots provided on all phases.
3. 160, 320A 3 pole contactors UL listed and CSA certified.
4. UR recognition 600V

- Mechanically Interlocked Contactors on page A22 and A23 should be used if short circuit current can flow when switching between two or more contactors.
- For KW Rating Multiply HP Ratings by .746 (example: 100HP x .746 = 75KW)

Ordering Information

* Coil Table

- Use complete catalog number when ordering. Replace the (*) with the suffix from the coil table.
- Engineering Data page A30.
- Modification Data page A37.
- Renewal Parts page A36.

Voltage Suffix	
120 AC	-76
240 AC	-26
380 AC	-38
460 AC	-46
125V DC	-125
250V DC	-250

USAVAC - LOW & MEDIUM VOLTAGE

AC Mechanically Interlocked Vacuum Contactors Unwired

A



One 3 Pole, One 5 Pole, 320A Contactor

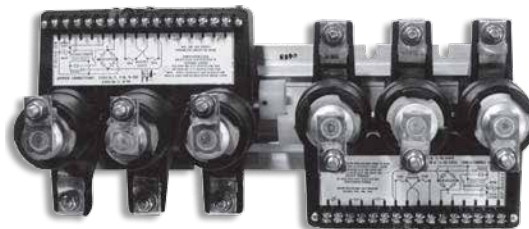

Two 3 Pole, 320A Contactors

USAVAC Vacuum Contactors mechanically interlocked suitable for use in reversing, Wye-Delta, reduced voltage auto transformer, and 2 speed single or two winding starters.

Mechanically Interlocked Unwired, 200V-1500V - Bulletin 7707

Ampere Rating	Maximum Horsepower Ratings - 3 Phase							Size	Open Type Catalog No.
	200/208V	230V	380V	460V	575V	1000V	1500V		
3 Pole - 3 Pole									
160 ³	50	60	100	125	150	300	420	160/160	VC31U03415 -* - 43 ²
320 ³	100	125	200	250	300	600	850	320/320	VC31U03515 -* - 43 ²
600	200	200	375	500	575	1200	1600	600/600	VC31U03615 -* - 43 ²
320 ³	100	125	200	250	300	600	850	320/160	VC82U03515 -* - 43 ²
600	200	200	375	500	575	1200	1600	600/320	VC82U03615 -* - 43 ²
5 Pole - 5 Pole¹									
160 ³	50	60	100	125	150	300	420	160/160	VC50U04C215 -* - 43 ²
320 ³	100	120	200	250	300	600	830	320/320	VC50U05C215 -* - 43 ²

For KW Rating Multiply HP Ratings by .746 (example: 100HP x .746 = 75KW)

Mechanically Interlocked Unwired, 1501V-3600V - Bulletin 7707

Ampere Rating	Maximum Horsepower Ratings - 3 Phase		Open Type Catalog No.
	2300V	3300V	
3 Pole - 3 Pole			
160 ⁴	600	960	VC31U03436 -* - 43 ²
320 ⁴	1250	1920	VC31U03536 -* - 43 ²
600 ³	2400	3700	VC31U03636 -* - 43 ²
3 Pole - 5 Pole¹			
160 ⁴	600	960	VC50U04C236 -* - 43 ²
320 ⁴	1250	1920	VC50U05C236 -* - 43 ²

Notes:

1. To be used for 2 speed single winding applications only.
2. Modification 43 in the catalog number suffix means power wiring between contactors not included.
3. Terminal boots provided on center phase.
4. Terminal boots provided on all phases.

Ordering Information

* Coil Table

- Use complete catalog number when ordering. Replace the (*) with the suffix from the coil table.
- Engineering Data page A30.
- Modification Data page A37.
- Renewal Parts page A36.

Voltage Suffix	
120 AC	-76
240 AC	-26

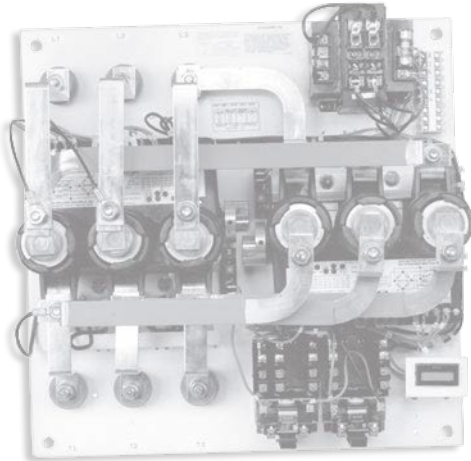

250 HP 460V Jog Duty Reverser with M.O.V. Suppressors

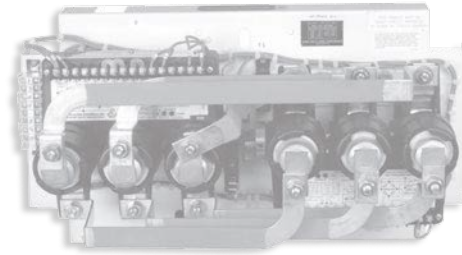

300 HP 575V Reverser

WIRED CONTACTORS NOT AVAILABLE,

3 Pole AC Reversing Contactors, 200V-1500V - Bulletin 6031

Ampere Rating	Maximum Horsepower Ratings - 3 Phase								Size	Open Type 1500V Standard Duty Catalog No.	Open Type 600V ¹ Jogging Duty Catalog No.
	200/208V	230V	380V	460V	575V	1000V	1500V				
160	50	60	100	125	150	300	420	4	VC31U03415 - *	VJ31U03406 - *	
320	100	125	200	250	300	600	850	5	VC31U02515 - *	VJ31U03506 - *	
600	200	300	375	500	575	1200	1500	6	VC31U03615 - *	VJ31U03606 - *	

SEE PAGE A22 FOR MECHANICALLY INTERLOCKED

UNITS OR CALL FACTORY

3 Pole AC Reversing Contactors, 1501V-3600V - Bulletin 6031

Ampere Rating ²	Maximum Horsepower Ratings - 3 Phase		Open Type 3600V Standard Duty Catalog No.
	2300V	3300V	
160	600	960	VC31U03436 - *
320	1250	1920	VC31U03536 - *

Notes:

1. To be used when application involves plugging & inching (e.g. crane control). M.O.V. suppressor included on power circuit. For other voltages consult factory.
2. Terminal boots provided on center phase.

For KW Rating Multiply HP Ratings by .746 (example: 100HP x .746 = 75KW)

Ordering Information

* Coil Table

- Use complete catalog number when ordering. Replace the (*) with the suffix from the coil table.
 - Engineering Data page A30.
 - Renewal Parts page A36.
- | Voltage Suffix | |
|----------------|-----|
| 120 AC | -76 |
| 240 AC | -26 |

USAVAC - LOW & MEDIUM VOLTAGE

AC Starters

A

- UL listed to 1500V
- CSA Certified to 1500V

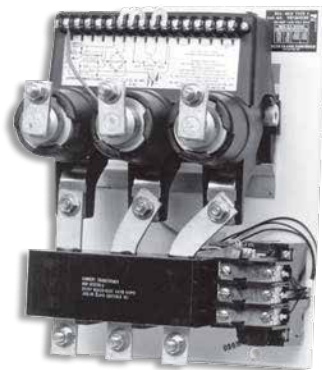

**Open Type
250HP 460V
850 HP 1500V**



**250 HP, 460V Non Combination
Starter in Type 1 Enclosure**

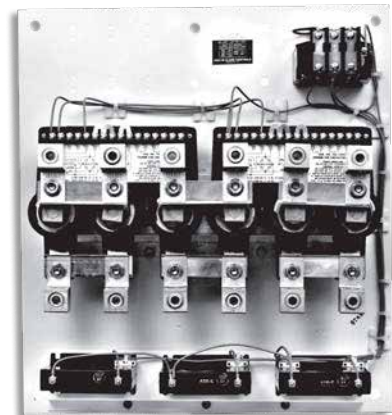

**Open Type
500HP 460V
1600 HP 1500V**

3 Pole AC Vacuum Starters, 200V-1500V - Bulletin 6013

Ampere Rating	Maximum Horsepower Ratings - 3 Phase							Size	NEMA Type 12 ¹ Catalog No.	NEMA Type 1 ¹ Catalog No.	Open Type ¹ Catalog No.
	200/208V	230V	380V	460V	575V	1000V	1500V				
135	40	50	75	100	125	-----	-----	4	VS13TA3406-*	VS13AA3406-*	VS13U03406-*
160	50	60	100	125	150	300	420	4	VS13TA3E15-*	VS13AA3E15-*	VS13U03E15-*
320	100	125	200	250	300	600	850	5	VS13TA3515-*	VS13AA3515-*	VS13U03515-*
600 ²	200	200	375	500	575	1200	1600	6	VS13TA3615-*	VS13AA3615-*	VS13U03615-*

- For NEMA 3R use NEMA 12 and change 5th character in catalog number to "R".
- For Latched Starters refer to Note (6) on page "A5" for Ordering Information.
- For KW Rating Multiply HP Ratings by .746 (example: 100HP x .746 = 75KW)

3 Pole AC Reversing Contactors, 1501V-3600V - Bulletin 6031

Ampere Rating	Maximum Horsepower Ratings - 3 Phase		Open Type ¹ Catalog No.
	2300V	3300V	
160 ⁴	600	960	VS13U03436 - *
320 ⁴	1250	1920	VS13U03536 - *
600 ^{2,3}	2400	3700	VS13U03636 - *

Notes:

1. Three overload heaters are required see page A35
2. Two 320 ampere contactors connected in parallel for 600A.
3. Terminal boots provided on center phase.
4. Terminal boots provided on all phases.

Ordering Information

* Coil Table

- Use complete catalog number when ordering. Replace the (*) with the suffix from the coil table.
- Engineering Data page A30.
- Modification Data page A37.
- Renewal Parts page A36.

Voltage Suffix	
120 AC	-76
240 AC	-26

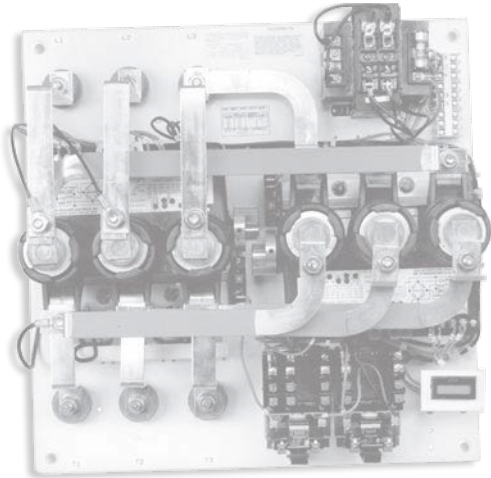

460V 250 HP Reversing Starter Suitable for Crane Control

WIRED CONTACTORS

3 Pole Wired Reversing Starters 200V-1500V - Bulletin 6730

Ampere Rating	Maximum Horsepower Ratings - 3 Phase								Open Type 1500V ¹ Standard Duty Catalog No.	Open Type 600V ^{1,2} Jogging Duty Catalog No.
	200/208V	230V	380V	460V	475V	500V	500V	500V		
135	40	50	75	100	125	150	175	200	VS30U03E06 - *	VJ30U03406 - *
160	50	60	100	125	150	300	420	4	VS30U03E15 - *	VJ30U03E06 - *
320	100	125	200	250	300	600	850	5	VS30U03E15 - *	VJ30U03E06 - *
600	200	250	375	500	600	1200	1600	6	VS30U03E15 - *	VJ30U03E06 - *

3 Pole Wired Reversing Starters 1501V-3600V - Bulletin 6000

Ampere Rating ³	Maximum Horsepower Ratings - 3 Phase		Open Type 3600V ¹ Standard Duty Catalog No. E
	2300V	3300V	
160	600	960	VS30U03E36 - *
320	1250	1920	VS30U03E36 - *

For KW Rating Multiply HP Ratings by .746 (example: 100HP x .746 = 75KW)

Notes:

1. Three overload heaters are required. See Page A35
2. To be used when application involves plugging & inching (e.g. crane control). Includes M.O.V. suppressors on power circuit. For other voltages consult factory.
3. Terminal boots provided on center phase.

Ordering Information

* Coil Table

- Use complete catalog number when ordering. Voltage Suffix
- Replace the (*) with the suffix from the coil table. 120 AC -76
- 240 AC -26
- Engineering Data page A30.
- Modification Data page A37.
- Renewal Parts page A36.

USAVAC - LOW VOLTAGE

AC Combination Starters

A

CV Series



300 HP 460V Starter in Type 12 Enclosure



400 HP 600V Starter in Type 3 Enclosure

NEMA 1 & 12 Combination Starters 200V-575V - Bulletin 6018/6020

Ampere Rating	Maximum Horsepower Ratings - 3 Phase					Size	NEMA Type 1 & 12 Flange Operator Catalog No.
	200/208V	230V	380V	460V	575V		
Non-Fusible							
135	40	50	75	100	125	4	CV18TA340610 -*
200	50	80	135	150	200	--	CV18TA32A610 -*
270	100	100	200	200	200	5	CV18TA35610 -*
400	160	160	270	300	400	--	CV18TA34A610 -*
600	180	250	300	500	500	6	CV18TA360610 -*
Fusible							
135	40	50	75	100	125	4	CV18TA340692 -*
200	50	80	100	125	150	4	CV18TA3E0692 -*
270	100	100	200	200	200	5	CV18TA35694 -*
400	160	160	270	300	400	--	CV18TA34A697 -*
600	180	250	300	500	500	6	CV18TA360698 -*
MCP							
135	40	50	75	100	125	4	CV20TA340678 -*
200	50	80	135	150	200	--	CV20TA3E0678 -*
270	100	100	200	200	200	5	CV20TA350679 -*
400	160	160	270	300	400	--	CV20TA34A681 -*
600	180	250	300	500	500	6	CV20TA360681 -*

- For NEMA 3R use NEMA 12 and change 5th character of catalog number to "R".

For KW Rating Multiply HP Ratings by .746 (example: 100HP x .746 = 75KW)

Ordering Information

* Coil Table

- Use complete catalog number when ordering. Replace the (*) with the suffix from the coil table.
- Engineering Data page A30.
- Modification Data page A37.
- Renewal Parts page A36.

Voltage Suffix	
120 AC	-76
240 AC	-26

Notes:

1. Three overload heaters are required.

USAVAC - LOW VOLTAGE

AC Combination Starters

A

VS Series



250 HP 460V Starter in
Type 12 Enclosure



300 HP 600V Starter in
Type 3 Enclosure

NEMA 1 & 12 Combination Starters 200V-575V - Bulletin 6018/6020

Ampere Rating	Maximum Horsepower Ratings - 3 Phase					Size	NEMA Type 1 & 12 ^{1,2} Flange Operator Catalog No.
	200/208V	230V	380V	460V	575V		
Non-Fusible							
135	40	50	75	100	125	4	VS18TA340610 -*
160 ²	50	60	100	125	150	4	VS18TA3E0610 -*
320 ²	100	100	200	250	300	5	VS18TA350610 -*
600	180	250	300	500	500	6	VS18TA36A610 -*
Fusible							
135	40	50	75	100	125	4	VS18TA340692 -*
160 ²	50	60	100	125	150	4	VS18TA3E0692 -*
320 ²	100	100	200	250	300	5	VS18TA350694 -*
600	180	250	300	500	500	6	VS18TA360697 -*
700	225	300	500	550	700	--	VS18TA370698 -*
MCP							
135	40	50	75	100	125	4	VS20TA340678 -*
160	50	60	100	150	150	4	VS20TA3E0678 -*
320	100	100	200	200	300	5	VS20TA350679 -*
600	180	250	300	300	500	6	VS20TA360680 -*
700	225	300	500	500	700	--	VS20TA370681 -*

For NEMA 3R use NEMA 12 and change 5th character of catalog number to "R".

For KW Rating Multiply HP Ratings by .746 (example: 100HP x .746 = 75KW)

Notes:

1. Three overload heaters are required.
2. Terminal boots provided on center phase.

Ordering Information

* Coil Table

- Use complete catalog number when ordering.

Voltage Suffix	
120 AC	-76
240 AC	-26

 Replace the (*) with the suffix from the coil table.
- Engineering Data page A30.
- Modification Data page A37.
- Renewal Parts page A36.

USAVAC - LOW VOLTAGE

AC Reduced Voltage Starters

A

Reduced Voltage - 600 Volts Rated Type CV & VS Auto Transformer Closed Transition

Designed for automatic starting of squirrel cage motors when the starting current must be reduced. Closed transition auto transformer starters provide the highest possible starting torque per ampere of line current.

Auto transformers are 3-coil type, with voltage taps at 50%, 65% and 80% rated in accordance with NEMA Standards ICS-214.21 for medium-duty starting service.



250HP, 460V R.V.A.T. Starter in NEMA 12 Enclosure

Vacuum Starters NEMA 1 & 12 Enclosed

Ampere Rating	Maximum Horsepower Ratings - 3 Phase		Size	NEMA 1 & 12, 230V ¹	NEMA 1 & 12, 460V ¹
	230V	460V		Industrial - Dust tight Catalog No.	Industrial - Dust tight Catalog No.
Non Combination - Bulletin 6082					
135	50	100	4	CV82TA4JB -*	CV82TA4ME -*
160 ²	60	125	4	VS82TAEKB -*	VS82TAENE -*
200	75	150	--	CV82TA2ALB -*	CV82TA2APE -*
320 ²	100	250	5	VS82TA5MB -*	VS82TA5RE -*
400	150	300	--	CV82TA4APB -*	CV82TA4ASE -*
600	200	500	6	CV82TA6QB -*	CV82TA6VE -*
Fusible Combination - Bulletin 6083					
135	50	100	4	CV83TA4JB -*	CV83TA4ME -*
160 ²	60	125	4	VS83TAEKB -*	VS83TAENE -*
200	75	150	--	CV83TA2ALB -*	CV83TA2APE -*
320 ²	100	250	5	VS83TA5MB -*	VS83TA5RE -*
400	150	300	--	CV83TA4APB -*	CV83TA4ASE -*
600	200	500	6	CV83TA6QB -*	CV83TA6VE -*
MCP Combination - Bulletin 6084					
135	50	100	4	CV84TA4JB -*	CV84TA4ME -*
160 ²	60	125	4	VS84TAEKB -*	VS84TAENE -*
200	75	150	--	CV84TA2ALB -*	CV84TA2APE -*
320 ²	100	250	5	VS84TA5MB -*	VS84TA5RE -*
400	175	350	--	CV84TA4APB -*	CV84TA4ASE -*
600	200	500	6	CV84TA6QB -*	CV84TA6VE -*

Notes:

1. Includes starter complete with 3 N.O. & 2 N.C. interlocks and three phase overload relays less heaters.
2. Terminal boots provided on center phase.
3. For NEMA 3R change the T in the catalog number to an R.

Ordering Information

*** Coil Table**

- Use complete catalog number when ordering.
- Replace the (*) with the suffix from the coil table.
- Engineering Data page A30.
- Modification Data page A37.
- Renewal Parts page A36.

Voltage Suffix	
120 AC	-76
240 AC	-26

Special Purpose Contactors

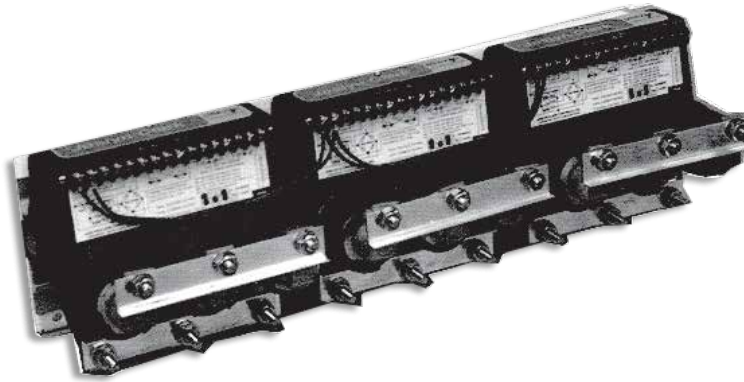

3 Pole Three Phase 1000A 3600V

The following controls are for high current applications such as electric arc and induction furnace.

Special Purpose Vacuum Contactors

Ampere Rating	1500V Open Type Catalog No.	3600V Open Type Catalog No.
1 Pole, Single Phase		
450	SVC77U014515 -*	SVC77U014536 -*
1000	SVC77U011015 -*	SVC77U011036 -*
1500	SVC77U011515 -*	SVC77U011536 -*
2500	SVC77U012515 -*	SVC77U012536 -*
2 Pole, Single Phase		
450	SVC77U024515 -*	¹ SVC77U024536 -*
1000	SVC77U021015 -*	¹ SVC77U021036 -*
1500	SVC77U021515 -*	¹ SVC77U021536 -*
3 Pole, Three Phase		
1000	SVC77U031015 -*	² SVC77U031036 -*

Notes:

1. Insulation boots provided on 1 pole.
2. Terminal boots provided on all phases.

Ordering Information

* Coil Table

- Use complete catalog number when ordering. Replace the (*) with the suffix from the coil table.
- Engineering Data page A30.
- Renewal Parts page A36.

Voltage Suffix	
120 AC	-76
240 AC	-26

USAVAC - LOW & MEDIUM VOLTAGE CONTACTORS & STARTERS

Engineering Data

Vacuum Contactor & Starter Ratings 200V-3600V

A

Catalog No. 3 Pole	160A		320A		600A		1000A	
	1.5KV	VC77U03415	VC77U03515	VC77U03615	VC77U03615	SVC77U031015	SVC77U031015	SVC77U031036
	3.6KV	VC77U03436	VC77U03536	VC77U03636	VC77U03636	SVC77U031036	SVC77U031036	SVC77U031036
Power Ratings								
Rated Insulating and Operational Voltage	1500/3600 ¹							
Rated Operational Current	160	320	600	1000				
Rated Frequency	50/400Hz ¹							
Making Current	1600	3200	6000	6000				
Breaking Current	1600	3200	6000	6000				
Dielectric Strength/BIL	6KV-1 min. / 45KV. 1.2 X 50 Micro/Sec.							
Interrupting Current	4400	5000	6000	6000				
Withstand Current	30KA-3Hz							
Short Time	1 Sec.	5000	7000	9000	11000			
Current -	2 Sec.	3000	5000	7000	9000			
Mechanical Life	2 x 10 ⁶							
Electrical Life at Rated Current - AC3 Duty	1 x 10 ⁶							
Switching Frequency	600/hr every 6 seconds							
Chop Current	.55A							
Max.	.9A							
Control Ratings								
Description	160/320A		600A		1000A			
Rated Control Voltage	120/240V 50/400Hz							
Allowable Fluctuation	+10% of rated -25% voltage							
Closing Power VA/Duration	950VA/17MS		1900VA/17MS		2850VA/17MS			
Holding Power	9VA		18VA		27VA			
Opening Time Ave.	90 MS at 60Hz							
Closing Time Ave.	17 MS at 60Hz							
Pick up Voltage	90V							
Drop Out Voltage	70% or less							
Recommended Control Transformer	When Required 250VA		When Required 500VA		When Required 750VA			
Application Conditions								
Installation	All Planes contactor only							
Altitude without Derating	Up to 6600 ft. (2000m)							
Ambient	Storage		-65°F (-54°C) +160°F (71°C)					
	Operating		-40°F (-40°C) +135°F (57°C)					
Vibration/Shock	40Hz - 2G/30G							
Weight 160/320A	12lbs. (5.45kg.)		24lbs. (11kg.)		36lbs. (16.36kg.)			
Dimensions	8 ⁷ / ₈ " x 7 ⁷ / ₈ " x 8 ¹ / ₄ " 225 x 189 x 200mm		17 ⁷ / ₈ " x 7 ⁷ / ₈ " x 8 ¹ / ₄ " 450x189x200mm		26 ⁵ / ₈ " x 7 ⁷ / ₈ " x 8 ¹ / ₄ "			

Technical Specifications

Open Type
USAVAC Starter Size 5

Accessories & Options:

1. Mechanical Interlocked contactors available, pages A22/23.
2. Vacuum starters in combination and non-combination forms are available in NEMA 1, 3, and 12 enclosures on, pages A24, 26 & 27
3. Terminal Lug Kits, page A36.
4. Suppressor Kits, page A36.

For KW Rating Multiply HP Ratings by .746 (example: 100HP x .746 = 75KW)

Volts	Motor HP			
	160A	320A	600A	1000A ²
230	60	125	200	-----
460	125	250	500	-----
1000	300	600	1200	-----
1500	420	850	1600	-----
2300	600	1250	2400	-----
3300	960	1920	3700	-----
Volts	Transformer Load KVA			
	160A	320A	600A	1000A
230	66	133	250	415
460	127	255	500	746
1000	277	554	1000	1730
1500	415	850	1500	2600
2300	665	1330	2500	4150
3300	910	1820	3400	5700
Volts	Capacitor Load KVAR			
	160A	320A	600A	1000A
230	50	100	180	310
460	95	190	360	595
1000	205	415	750	1300
1500	310	620	1125	1450
2300	500	1000	1875	3110
3300	700	1365	2550	4275

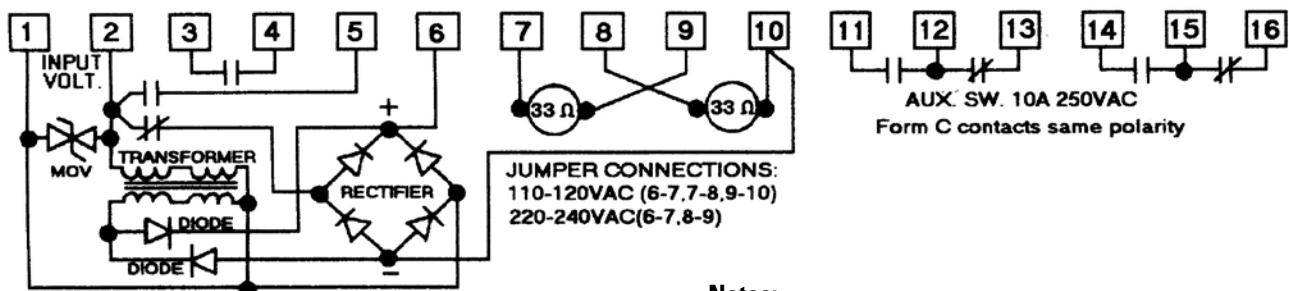

Control Diagram

UL/CSA 1500V
UR/CSA 3600V

Notes:

1. 3600V model has a B.I.L. rating of 45KV and an interrupt rating of 4000A.
2. Motor applications ratings are limited to 1000A continuous with maximum LRC of 6000 ampere.

USAVAC - LOW & MEDIUM VOLTAGE

Dimensions

A

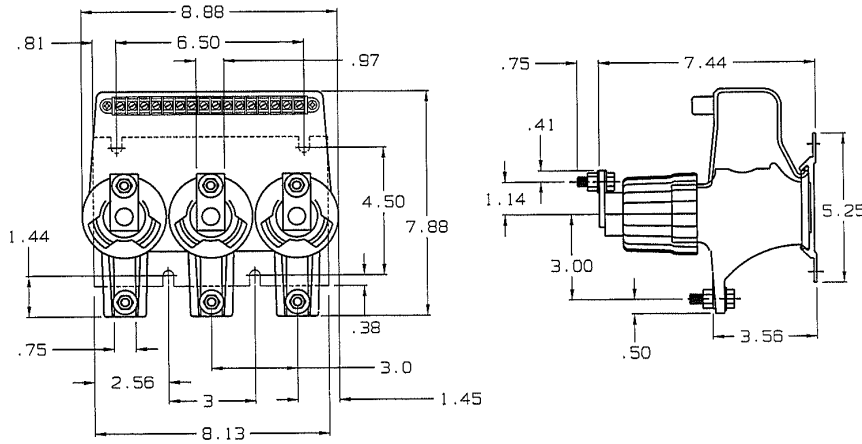

160-320 A 2-3 Pole 1.5 KV (As Shown)
 450 A Single Phase 1 Pole (Center Pole Removed)
 1000 A Single Phase 1 Pole (All 3 Paralleled)

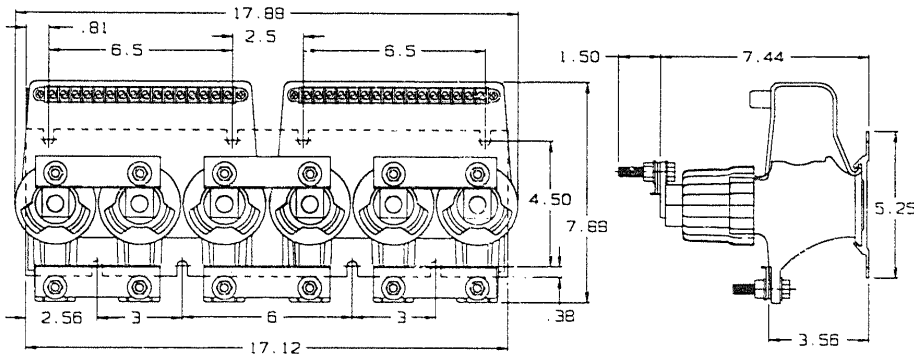

450 A Single Phase 12 Pole (Center Pole Removed)
 600 A Three Phase 1.5 KV (As Shown)
 1000 A single Phase 2 Pole (2X3 Pole Paralleled)
 1500 A Single Phase 1 Pole (All 6 Paralleled)

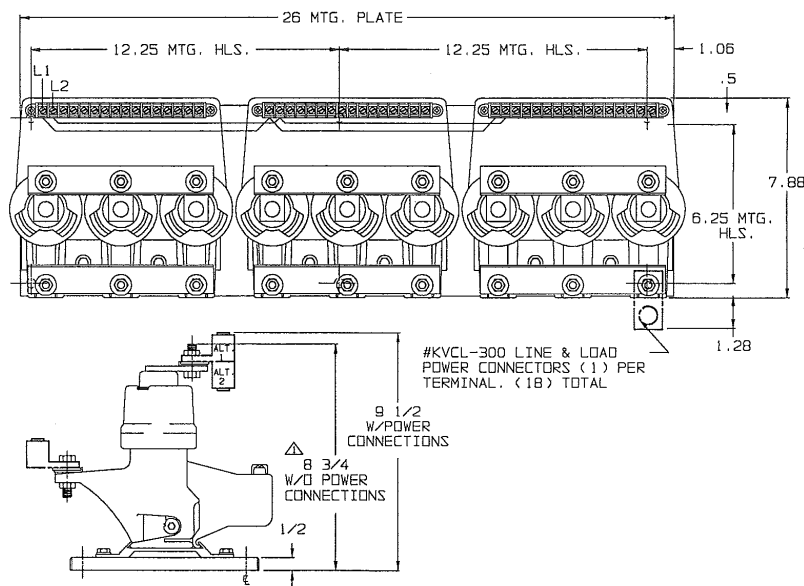

1000 A Three Phase 1.5 KV (As Shown)
 1500 A Single Phase 2 Pole (Center Pole Removed) 2X4 Pole Paralleled
 2500 A Single Phase 1 Pole (All 9 Paralleled)

#KVCL-300 LINE & LOAD
 POWER CONNECTORS (1) PER
 TERMINAL. (18) TOTAL

9 1/2
 W/POWER
 CONNECTIONS

8 3/4
 W/O POWER
 CONNECTIONS

USAVAC - LOW VOLTAGE

Dimensions

A

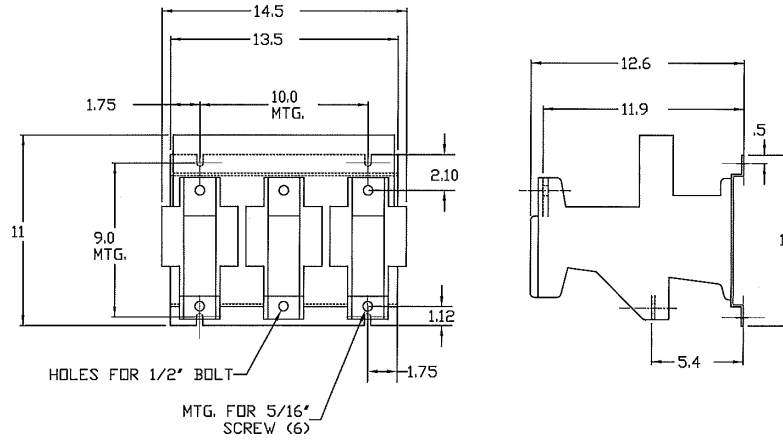

700 Amp
600V
3 Phase

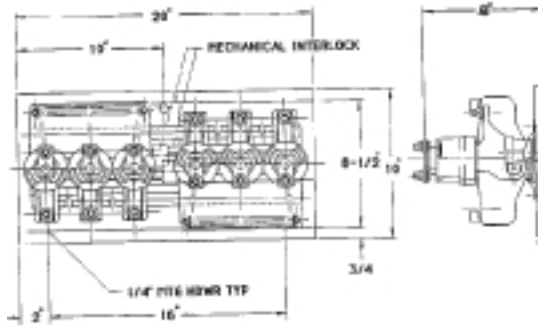

Mechanically Interlocked 160/320A Contactors

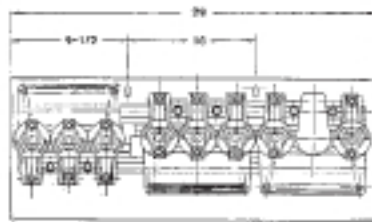

Mechanically Interlocked Contactors
3 Pole/5 Pole 160-320A

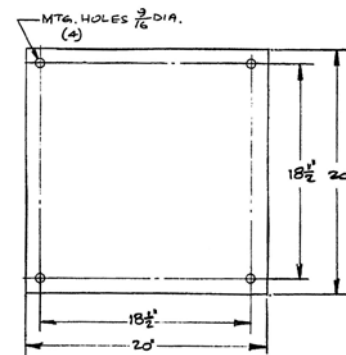

Open, Reverser, Standard or Jogging Duty
160-320A

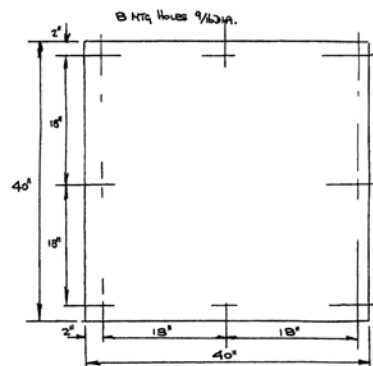

Open Type, Reverser Standard, or Jogging Duty 600A

A

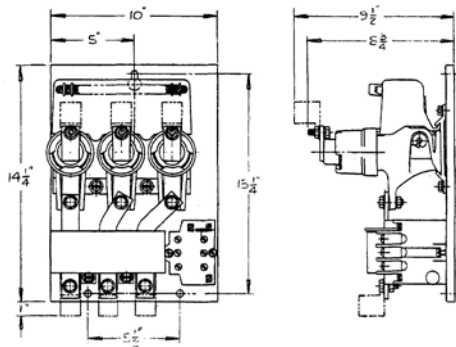

Open Starter 160/320A 1.5 KV

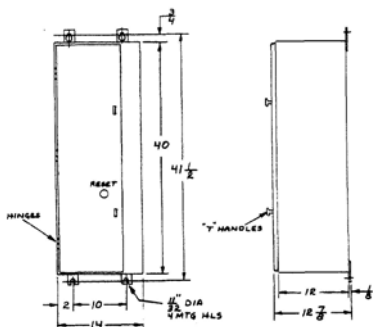

NEMA 1, 12 Non Combination Starter
160/320A

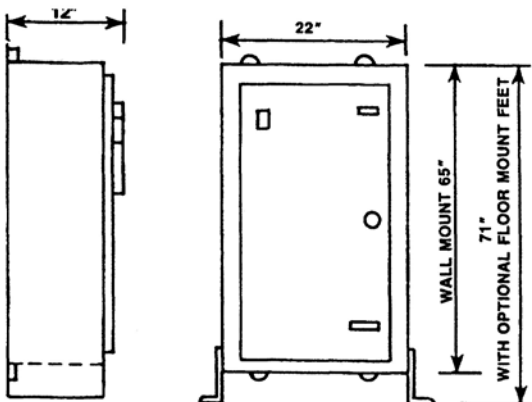

NEMA 1, 12 Combination Starter Fusible & Non Fusible
600 V- 135, 160, 320 AMP.

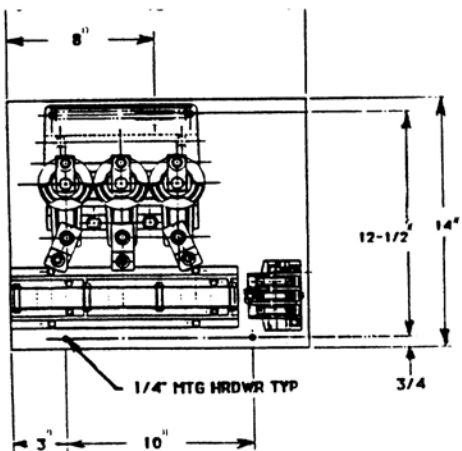

Open Starter 3.3 KV, 160-320A

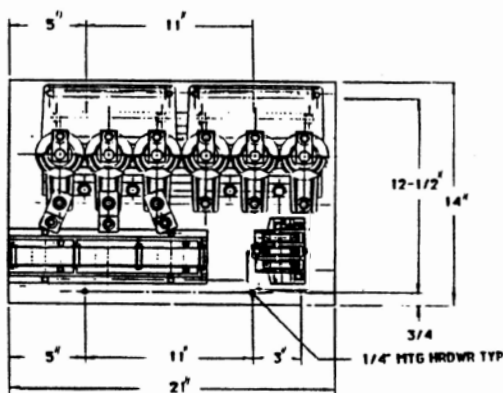

Open Starter 1.5/3.3 KV, 600A

USAVAC - LOW VOLTAGE

Dimensions

A

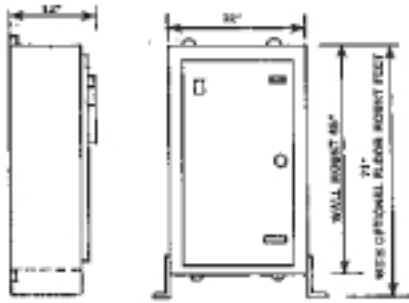

1.5 KV NEMA 1, 12 Standard Width
160-320A Fusible Combination Starters

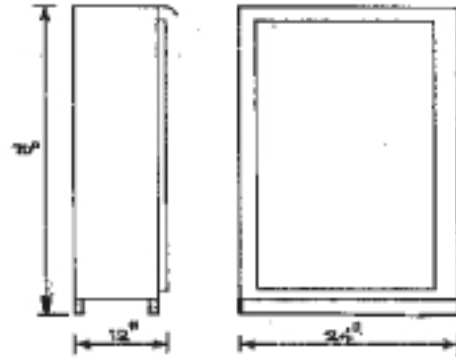

1.5 KV NEMA 1, 12, 600A
Fusible Combination Starters

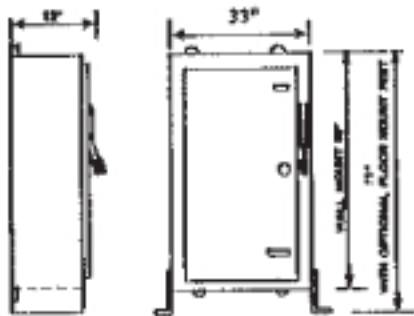

1.5 KV NEMA 3 Extra Wide
160-320A Fusible Combination Starters

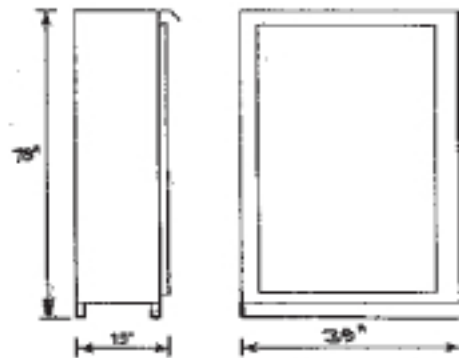

RVAT Starter 135-160-320A
230V-460V Combination Starter

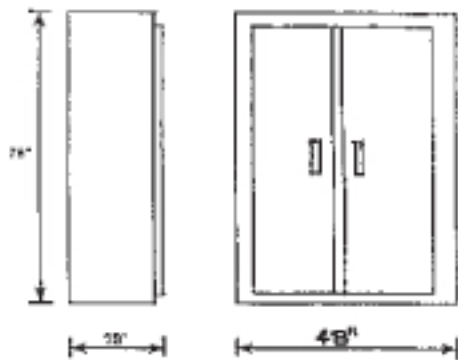

RVAT Starter 600A 230/460V
Combination Starters

USAVAC - LOW & MEDIUM VOLTAGE Overload Heaters

A

Heater Selection

Select heaters based on motor nameplate full-load current. Tables are for continuous rated motors. Full-load current for a given horsepower motor will vary from one manufacturer to another and will depend on RPM of motor.

Type of Protection

Heaters selected directly from the tables provide a maximum of 125% protection at 40°C ambient, is suitable for motors with a 1.15 service factor with a 40°C rise or less and with motor and controller at the same temperature. For motors with 1.0 service factor or with a temperature rise greater than 40°C without service factor rating, use one size smaller heaters than in table. The ultimate trip of the heater is approximately 125% of the minimum current shown in the tables in a 40°C ambient. The overload relay provides protection in accordance with UL Class 20. For further data refer to Controlog section B.

Ambient Correction

Not necessary when overload relay is ambient compensated as identified by green reset rod. For control at an ambient constantly less than the motor ambient, correct by decreasing the nameplate motor full-load current by 8% per 10°C difference in ambient. For control at an ambient constantly greater than the motor ambient, correct by increasing the nameplate motor full-load current by 8% per 10°C difference in ambient.

Branch Circuit Protection

Branch circuit protection should be provided per USA National Electric Code or the Canadian Electrical Code. Current rating of the protective device must not exceed the maximum value listed in the table.

Automatic Reset

Automatic reset operation should not be used with two-wire control.

HEATER APPLICATION TABLE FOR 3 PHASE MOTORS		
Bul. 6013, 6030, & 6050 Type CV-200 Standard or Ambient Compensated Overload Relay for use with 400:5 Current Transformer		
HEATER CAT. NO.	MIN.	MAX.
2421	87.0	96.5
2422	96.6	104.9
2423	105.0	117.7
2424	117.8	131.1
2425	131.2	137.5
2426	137.6	152.9
2427	153.0	171.4
2429	171.5	185.5
2430	185.6	200.0

CV 4 HEATER APPLICATION TABLE						
NON-REVERSING, REVERSING AND MULTI-SPEED, WITH STANDARD OR AMBIENT COMPENSATED OVERLOAD RELAY						
ENCL. STANDARD TYPE OPEN OR ENCL. AMBIENT COMP. TYPE	HEATER CATALOG NUMBER	PROTECTIVE DEVICE MAXIMUM FUSE	INVERSE TIME BREAKERS CONT. AMPS.	STARTER SIZE	MOTOR CONTINUOUS AMPERE RATING	
					MIN.	MAX.
	2525	125	70	3	28.6	31.6
	2526	125	70		31.7	35.2
	2527	150	70		35.3	39.1
	2528	150	70		39.2	42.3
	2529	175	100		42.4	46.4
	2530	200	100		46.5	50.8
	2531	225	100		50.9	57.3
	2532	250	100		57.4	63.7
	2533	250	100		63.8	70.7
	2534	300	125		70.8	77.3
	2535	300	150		77.4	83.1
	2536	300	150		83.2	90.0
	2536	350	150	4	83.2	90.9
	2537	350	150		91.0	97.6
	2538	400	150		97.7	106.0
	2539	450	200		106.1	115.4
	2540	450	200		115.5	123.9
	2541	450	200		124.0	135.0

HEATER APPLICATION TABLE FOR 3 PHASE MOTORS			
Bul. 6013, 6030, & 6050 Type Cv5, Cv6, Cv400 & Cv600. Standard or Ambient Compensated Overload Relay for use with 500:5 Current Transformer			
HEATER CAT. NO.	MIN.	MAX.	STARTER SIZE
2425	198.0	215.0	5
2426	215.1	237.0	
2427	237.1	267.0	
2429	267.1	270.0	
2429	267.1	289.0	
2430	289.1	324.0	
2431	324.1	351.0	
2432	351.1	390.0	
2433	390.1	400.0	
2433	390.1	425.0	
2434	425.1	487.0	
2435	487.1	540.0	
2435	487.1	548.0	
2436	548.1	600.0	

HEATER APPLICATION TABLE FOR 3 PHASE MOTORS		
BUL. 6013 TYPE VS SIZE 4 STANDARD OR AMBIENT COMPENSATED OVERLOAD RELAY		
MOTOR CONTINUOUS AMPERE RATING	HEATER CATALOG NUMBER	MOTOR CONTINUOUS AMPERE RATING
		MIN.
29.2	32.3	2525
32.4	36.0	2526
36.1	39.9	2527
40.0	43.4	2528
43.5	47.6	2529
47.7	52.4	2530
52.5	59.2	2531
59.3	66.0	2532
66.1	73.3	2533
73.4	80.4	2534
80.5	87.9	2535
88.0	95.0	2536
95.1	102.7	2537
102.8	111.9	2538
112.0	122.9	2539
123.0	133.9	2540
134.0	145.0*	2541*

HEATER APPLICATION TABLE FOR 3 PHASE MOTORS			
Bul. 6013, 6030, & 6050 Type VS Size 4, E, and 5 Standard or Ambient Compensated Overload Relay for use with 400:5 Current Transformer			
MAX.	MIN.	600 A.	STARTER SIZE
44.9	49.6	2413	4
49.6	56.0	2414	
56.1	61.6	2415	
61.7	68.0	2416	
68.1	76.7	2417	
76.8	81.5	2418	
81.6	89.4	2419	
89.5	94.1	2420	
94.2	105.9	2421	
106.0	119.9	2422	
120.0	134.4	2423	
134.5	135.0	2424	
135.1	156.9	2424	
157.0	160.0	2425	
160.1	170.9	2425	
171.0	188.9	2426	
189.0	211.9	2427	
212.0	229.9	2429	
230.0	256.9	2430	
257.0	280.9	2431	
281.0	304.0	2432	
304.0	320.0	2433	

HEATER APPLICATION TABLE FOR 3 PHASE MOTORS				
Type VS Size 6 Standard or Ambient Compensated Overload Relay For use with 400/5 Current Transformer				
HEATER CATALOG NUMBER	MOTOR AMPERE RATING		INVERSE TIME CIRCUIT BREAKER MAGNETIC TRIP SETTING	
	MAX.	MIN.	600 A.	800 A.
2421	106.0	95.2	LOW	LOW
2422	121.0	106.1	LOW	LOW
2423	136.0	121.1	LOW	LOW
2424	158.0	136.1	LOW	LOW
2425	172.0	158.1	LOW	LOW
2426	190.0	172.1	LOW	LOW
2427	214.0	190.1	LOW	LOW
2429	231.0	214.1	LOW	LOW
2430	259.0	231.1	LOW	LOW
2431	281.0	259.1	2	LOW
2432	312.0	281.1	3	LOW
2433	340.0	312.1	3	LOW
2434	390.0	340.1	4	2
2435	438.0	390.1	6	3
2436	484.0	438.1	7	3
2437	520.0	484.1	HIGH	4
2438	590.0	520.1	HIGH	6
2439	600.0	590.1	HIGH	6

USAVAC - VACUUM CONTROL

Accessories / Parts

A

Low Voltage Contactors 200V - 3.6Kv

Description	Rating	Catalog Number
Accessories - Discount Schedule JC11		
Terminal Boots	Line Side (1 Per Kit)	KVC-UB1
	Load Side (1 Per Kit)	KVC-UL1
Parts - Discount Schedule JC80		
Phase Assembly Fig. 1	160 ampere (1 Per Kit)	A77-354115A-1
	320 ampere (1 Per Kit)	A77-354115A-2
	600 ampere	A77-354115A-2
	1000 ampere	A77-354115A-2
Control Module Fig. 2	120/240V, 50/60Hz (1 Per Kit)	A77-354117A
	125V DC (1 Per Kit)	A77-452580A-2
	250V DC (1 Per Kit)	A77-452580A-4



Fig. 1



Fig. 2

Notes:

When ordering for 600A Rating, Qty. (2) of a 320A Phase Assembly are required Per Pole.

When ordering for a 1000A Rating, Qty. (3) of a 320A Phase Assembly are required Per Pole.

Medium Voltage Contactors 2.3 - 7.2Kv

Description	Rating	Catalog Number
Accessories - Discount Schedule JC19		
Auxiliary Contacts	2N.O. & 2 N.C. Auxiliary Block	A77-358002
Parts - Discount Schedule JC80		
Phase Assembly (Half Shell) Fig. 3	200 ampere (1 Per Kit)	A77-356249A-1
	400 ampere (1 Per Kit)	A77-356249A-2
	600 ampere (1 Per Kit)	A77-356249A-3
	700 ampere	A77-356249A-5
	1200 ampere	A77-356249A-4
Phase Assembly	Complete 3 Phase Assembly	A77-359473A-1
	Complete 1 Pole Assembly	A77-359473A-2
Control Module Fig. 4	120V, 50/60Hz (1 Per Kit)	A77-356277A-1
	240V, 50/60Hz (1 Per Kit)	A77-356277A-2
	380/460V, 50/60Hz	A77-356277A-4
	125V DC (1 Per Kit)	A77-452563A-2
	250V DC (1 Per Kit)	A77-452563A-4



Fig. 3



Fig. 4

Modifications For Combination and Non-Combination Controllers

Description	Change Cat. No. Character Indicated To:	Typical Catalog Number
Cover Controls		
Push Buttons & Selector Switches Hand-Off-Auto Selector Switch	B	
Start-Stop Push Buttons	C	
2 or 3 Position Selector Switch - SPDT	B	
Forward-Reverse-Stop Push Buttons	C	
High-Low-Stop Push Buttons Fast-Slow-Stop Push Buttons	C	
Pilot Lights With Electrical Interlock: Standard Transformer Type, Red Lens	13	
Push-to-Test Transformer Type, Red Lens	14	
Modification 14. Lens color below. Example: Order 15 = Std. Transformer with interlock & color lens	13+15	
Green		
Blue	13+16	
White	13+17	
Yellow	13+18	
Amber	13+19	
Clear	13+20	
Auxiliary Relays		
Extra 2 N, 0 & 2 N.C. Aux. Contacts	21	
Time Relay ON Delay	22	
Time Relay OFF Delay	23	
Time Relay ON Delay & Instantaneous	24	
Time Relay OFF Delay & Instantaneous	25	
Time Relay ON Delay & OFF Delay	26	

Ordering Example:

VS18TA350694-76 with the following modifications:	VS18TA350694-76
1 - Hand-Off-Auto Selector Switch	B
1 - Transformer operated Red Pilot with Interlock	13
1 - Transformer operated Green Pilot Light with Interlock	13 + 15

USAVAC - LOW VOLTAGE VACUUM CONTROL

Modifications

A

Modifications

Description	Change Cat. No. Character Indicated To:	Typical Catalog Number
Overload Relay		
777 Electronic Motor Management Relay 970	27	
RM 2000 motor Monitor for use with 777	27A	
Power Circuit		
Standard Capacity - Primary Volts/Hertz:		
220-240/60 or 220/50	-T26	
440-480/60 or 440/50	-T46	
550-600/60 or 550/50	-T56	
200-208/60	-T86	
380/50	-T35	
220/25	-T22	
440/25	-T42	
100 Watts Extra - Primary Volts/Hertz:		
220-240/60 or 220/50	-C26	
440-480/60 or 440/50	-C46	
550-600/60 or 550/50	-C56	
200-208/60	-C86	
380/50	-C35	
220/25	-C22	
440/25	-C42	
Fused Primary (Includes 2 Fuses)	30	
Control Circuit Separate	31	
Fused Control Circuit, 2 fuses included	32	
3 Phase Voltage Monitor Relay, Phase loss, Phase reversal	33A	
Digital Power Meter		35A
* Ammeter 3 Phase	* Digital Power Meter:	
* Voltmeter 3 Phase	All functions included in	
* Power (KW) Wattmeter	Mod. 35A	
* Energy (KWH) KWH Meter		
* PF Meter		
* Frequency Meter		
* Reactive Power (KVAR)		
Contactors MI 320/160A 3 Phase	See page A22	
Contactors MI 600/320A 3 Phase	See page A22	

Ordering & Pricing Example:

VS18TA350694-76 with the following modifications: VS18TA350694-76

1 - 3 Phase Voltage Monitor Relay (Phase loss, Phase reversal) 33A
Complete Cat# VS18TA350694-76-33A

USAVAC - MEDIUM VOLTAGE

AC Vacuum Contactors

A

- UL Recognition ¹
- CSA Certified ¹
- Electrically Held AC or DC Closing Coils



Ratings Include 2.5, 5.0, 7.2KV, 200, 400, 600, 800 and 1200 Ampere

3 Pole Vacuum Contactors - Bulletin 7707

Ampere Rating	Maximum Horsepower Ratings		Open Type Catalog No.
	8pf Ind. or Syn. Motor	1.0 pf Syn. Motor	
2500 Volts			
200	900	1000	MVC77U032A25 -*
400	1750	2000	MVC77U034A25 -*
600	2250	2500	MVC77U036A25 -*
800	2750	-----	SVC77U038A25 -*
1200	-----	-----	SVC77U031225 -*
4160 Volts			
200	1500	1750	MVC77U032A50 -*
400	3000	3500	MVC77U034A50 -*
600	4500	4750	MVC77U036A50 -*
800	5500	-----	SVC77U038A50 -*
1200	-----	-----	SVC77U031250 -*
6600 Volts			
200	2500	2750	MVC77U032A72 -*
400	5000	5250	MVC77U034A72 -*
600	6750	7000	MVC77U036A72 -*
800	8000	-----	SVC77U038A72 -*
1200	-----	-----	SVC77U031272 -*

Notes:

1. UL recognized 5KV 500A 7.2KV 400A
CSA Certified 5KV 400A

Mechanically Interlocked Contactors on Page A41 should be used if short circuit current can flow when switching between two or more contactors.

Ordering Information

* Coil Table

- Use complete catalog number when ordering.
Replace the (*) with the suffix from the coil table.
- Engineering Data page A43.
- Renewal Parts page A36.

Voltage Suffix	
120 AC	-76
240 AC	-26
125V DC	-125
250V DC	-250

USAVAC - MEDIUM VOLTAGE

AC Vacuum Contactors

A



Ratings Include 2.5, 5.0, 7.2KV,
200, 400, 600 Ampere

- **UL Recognition ¹**
- **CSA Certified 5KV 400A ¹With Separate Mechanically Latched Close and Trip Coils**

3 Pole Vacuum Contactors - Bulletin 7707

Ampere Rating	Maximum Horsepower Ratings		Open Type Catalog No.
	.8pf Ind. or Syn. Motor	1.0 pf Syn. Motor	
2500 Volts			
200	900	900	MVCL77U032A25 -*
400	1750	1750	MVCL77U034A25 -*
600	2250	2250	MVCL77U036A25 -*
1200			MVCL77U0312A25 -*
4160 Volts			
200	200	1500	MVCL77U032A50 -*
400	400	3000	MVCL77U034A50 -*
600	600	4500	MVCL77U036A50 -*
1200			MVCL77U031250 -*
6600 Volts			
200	200	2500	MVCL77U032A72 -*
400	400	5000	MVCL77U034A72 -*
600	600	6750	MVCL77U036A72 -*
1200			MVCL77U031272 -*

Notes:

1. UL recognized 5KV 500A 7.2KV 400A
CSA Certified 5KV 400A

Mechanically Interlocked Contactors on Page A41 should be used if short circuit current can flow when switching between two or more contactors.

Ordering Information

* Coil Table

- Use complete catalog number when ordering. Replace the (*) with the suffix from the coil table.
- Engineering Data page A43.
- Renewal Parts page A36.

Voltage Suffix	
120 AC	-76
240 AC	-26
125V DC	-125
250V DC	-250

USAVAC - MEDIUM VOLTAGE Mechanically Interlocked Contactor

A

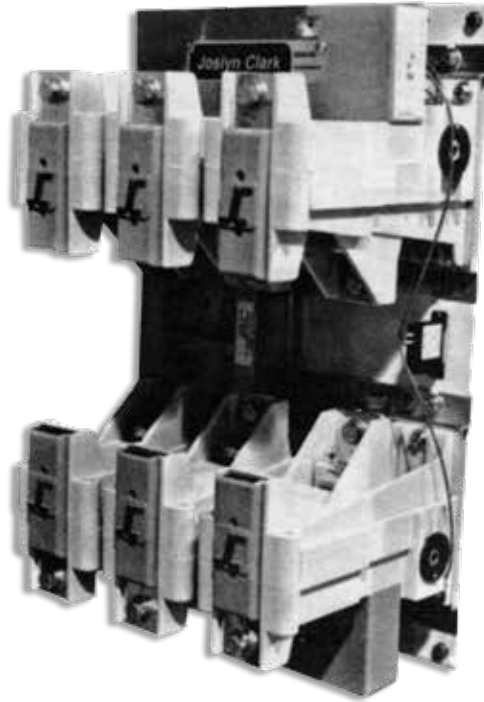

3 Pole - 3 Pole Mechanically Interlocked - Bulletin 6031

Ampere Rating	Maximum Horsepower Ratings		Open Type Catalog No.
	.8pf Ind. or Syn. Motor	1.0 pf Syn. Motor	
2500 Volts			
200	900	1000	MVC31U032A25 -*
400	1795	2000	MVC31U034A25 -*
600	2250	2500	MVC31U036A25 -*
4160 Volts			
200	1500	1750	MVC31U032A50 -*
400	3000	3500	MVC31U034A50 -*
600	4500	4750	MVC31U036A50 -*
6600 Volts			
200	2500	2750	MVC31U032A72 -*
400	5000	5250	MVC31U034A72 -*
600	6750	7000	MVC31U036A72 -*

Ordering Information

* Coil Table

- Use complete catalog number when ordering. Replace the (*) with the suffix from the coil table.
- Engineering Data page A43.
- Renewal Parts page A36.

Voltage Suffix	
120 AC	76
240 AC	26

USAVAC - MEDIUM VOLTAGE

AC Vacuum Contactors

A

Special Purpose Contactors
3000A Single Phase
1200A Three Phase

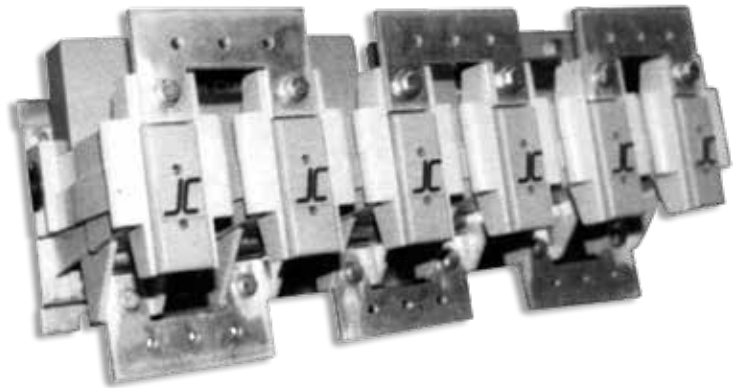

The following controls are for high current applications such as electric arc and induction furnaces.

Special Purpose Vacuum Contactors - Bulletin 7707

Ampere Rating	Open Type, 2500V Catalog No.	Open Type, 5000V Catalog No.	Open Type, 7200V Catalog No.
1 Pole, Single Phase			
1000	SVC77U011025 -*	SVC77U011050 -*	SVC77U011072 -*
1500	SVC77U011525 -*	SVC77U011550 -*	SVC77U011572 -*
2000	SVC77U012025 -*	SVC77U012050 -*	SVC77U012072 -*
3000	SVC77U013025 -*	SVC77U013050 -*	SVC77U013072 -*
2 Pole, Single Phase			
200	SVC77U022A25 -*	SVC77U022A50 -*	SVC77U022A72 -*
400	SVC77U024A25 -*	SVC77U024A50 -*	SVC77U024A72 -*
600	SVC77U026A25 -*	SVC77U026A50 -*	SVC77U026A72 -*
1000	SVC77U021025 -*	SVC77U021050 -*	SVC77U021072 -*
1500	SVC77U021525 -*	SVC77U021550 -*	SVC77U021572 -*
3 Pole, Three Phase			
800	SVC77U038A25 -*	SVC77U038A50 -*	SVC77U038A72 -*
1200	SVC77U031225 -*	SVC77U031250 -*	SVC77U031272 -*

Ordering Information

* Coil Table

- Use complete catalog number when ordering. Replace the (*) with the suffix from the coil table.
- Engineering Data page A43.
- Renewal Parts page A36.

Voltage Suffix	
120 AC	76
240 AC	26

Vacuum Contactor & Starter Ratings

Standard - NEMA ICS 2-324, UL 347, CSA 22.2, IEC 470, BS 775

Description		200A	400A	600	1200
Catalog Number & 2.5KV		MVC77U032A25	MVC77U031A25	MVC77U036A25	SVC77U031225
Rated Voltage	5.0KV	MVC77U032A50	MVC77U034A50	MVC77U036A50	SVC77U031250
	7.2KV	MVC77U032A72	MVC77U034A72	MVC77U036A72	SVC77U031272

Power Ratings		200A	400A	600A	800/1200A
Operational Rated Current		200A	400A	600A	800/1200A
Operational Rated Frequency HZ		50/60	50/60	50/60	50/60
E1 Interrupt Rating	2.5KV	20 MVA Equivalent to 4.62 KA			-----
MVA & KA Values	5.0KV	40 MVA Equivalent to 4.62 KA			-----
Contactor Only	7.2KV	60 MVA Equivalent to 4.81 KA			-----
E2 Fuse Coordination	Rating	400 MVA 45.7 KA RMS			-----
MVA & KA	5.0KV	38R max. fuse size			-----
Withstand KA	5.0KV	57.8 KA - Peak, 38R - Fuse			-----
Short Time Current	1 Sec. KA	6	7	9	12
	5 Sec. KA	4	5	6	9
	15 Sec. KA	2	2.6	3	6
Switching Frequency		300/Hr			
Elec. Life at Rated Current		.6 x 10 ⁶	.40 x 10 ⁶	.250 x 10 ⁶	.250 x 10 ⁶
Mechanical Life		.75 x 10 ⁶			
Dielectric Strength		20KV 1 min.			
Impulse withstand B.I.L.		1.2 x 50 us 60KV			
Chopping Current Max.		.9A			
Control Ratings AC&DC					
Rated Control Voltage		120/240V 50/60Hz AC or 125/250V DC			
Allowable Fluctuation		+10-15%		+10-20%	
Closing Power VA/Duration		650VA/45MS		1300VA/45MS	
Holding Power		7VA AC .47A DC		14VA AC .924A DC	
Opening Time Ave.		90 MS at 60Hz			
Closing Time Ave.		40 MS at 60 Hz			
Pick up Voltage	Min.	102V or less			
Drop Out Voltage	Ave.	70% or less			
Recommended Control Trans.		(AC Only)	300VA	600VA	
Application Conditions					
Standard	Current	Continuous AC/DC 10A/5A			
Auxiliary	Voltage	600V Max. - 48V Min. NEMA A600 (AC) P600 (DC)			
Contact	AC	Make/Break 7200VA/720VA			
Ratings	DC	Make/Break 125/250V 138VA 300/600V 138VA			
Additional	Current	Continuous AC/DC 10A/2.5A			
Auxiliary Contact	Voltage	600V Max. - 48 Min. NEMA A600 (AC) Q300 (DC)			
Relay Ratings	AC	Make/Break 7200VA/720VA			
	DC	Make/Break 125/250V/69VA			
Weight		48 lbs.		96 lbs.	

Technical Specifications

CSA 5KV. 400A

UL Recognized 5KV 500A 7.2KV 400A

A

Power Application Ratings

Voltage KV	Current	2.5	3.3	4.16	6.6
Motor Type		Motor HP			
.8 P.F. Ind. or Syn Motor	200A	900	1250	1500	2500
1.0 P.F. Syn Motor	200A	1000	1500	1750	2750
.8 P.F. Ind. or Syn Motor	400A	1750	2250	3500	5000
1.0 P.F. Syn Motor	400A	2000	2500	3500	5250
.8 P.F. Ind. or Syn Motor	600A	2250	3250	4500	6750
1.0 P.F. Syn Motor	600A	2250	3500	4750	7000
.8 P.F. Ind. or Syn Motor	800A	2750	4000	5500	8000
Transformer Load KVA					
Three Phase Transformer	200A	750	1000	1500	2000
	400A	1500	2000	3000	4000
	600A	2500	3000	4250	6000
	800A	2750	3750	5250	7500
	1200A	4100	5000	7000	10000
Capacitor Load KVAR					
Three Phase Capacitor	200A	550	750	1050	1500
	400A	1125	1500	2250	3000
	600A	1650	2250	3375	4500
	800A	2200	2900	4500	5000
	1200A	2750	3750	5625	7500

Accessories & Options:

- 1, 2, 4, & 5 Pole contactors, consult factory.
2. Mechanically interlocked contactors available.
3. Medium voltage starters available in non-drawout designs in NEMA 12 & 3 enclosures, consult factory.
4. Terminal Lug Kits available.

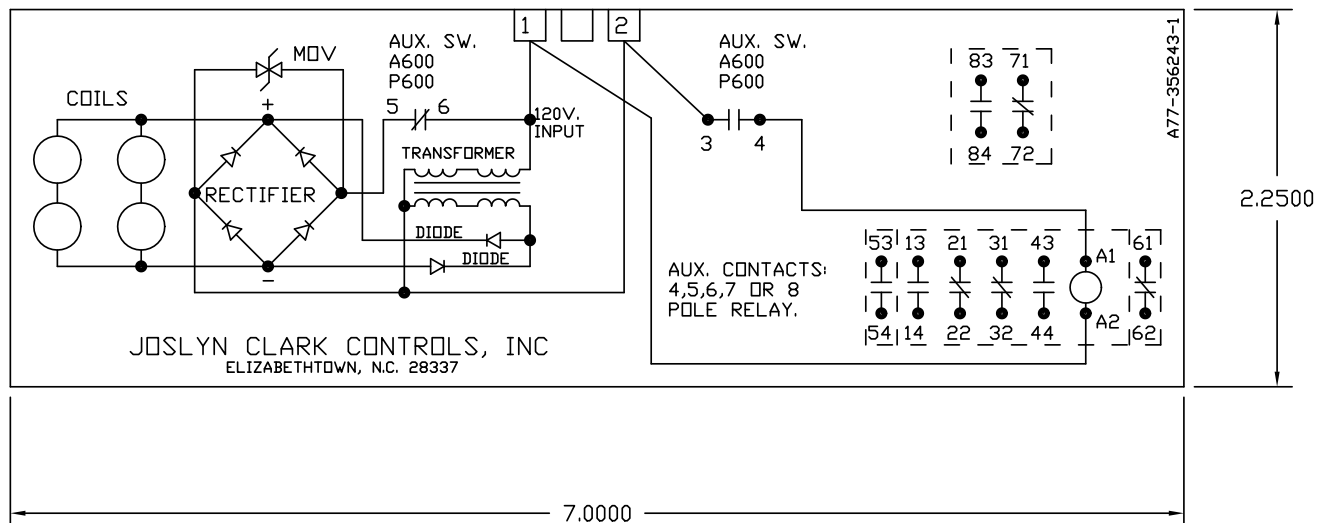

USAVAC - MEDIUM VOLTAGE

Dimensions

A

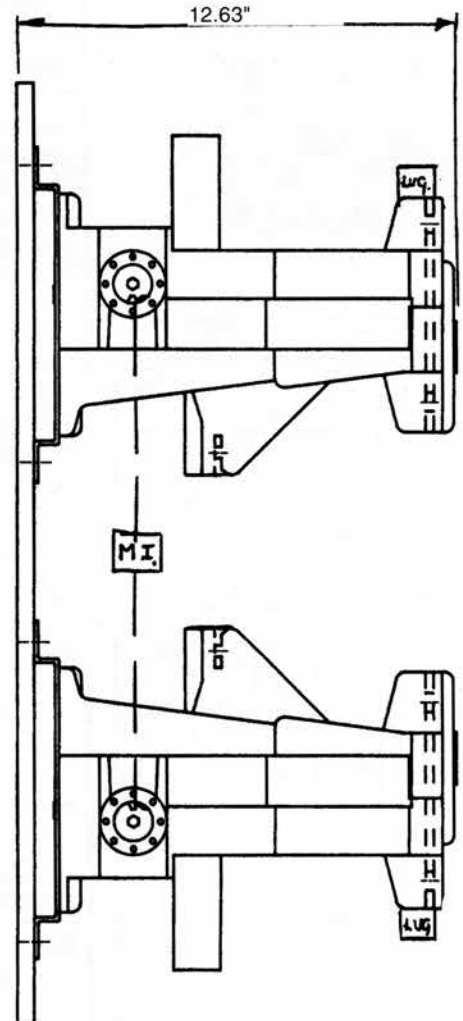
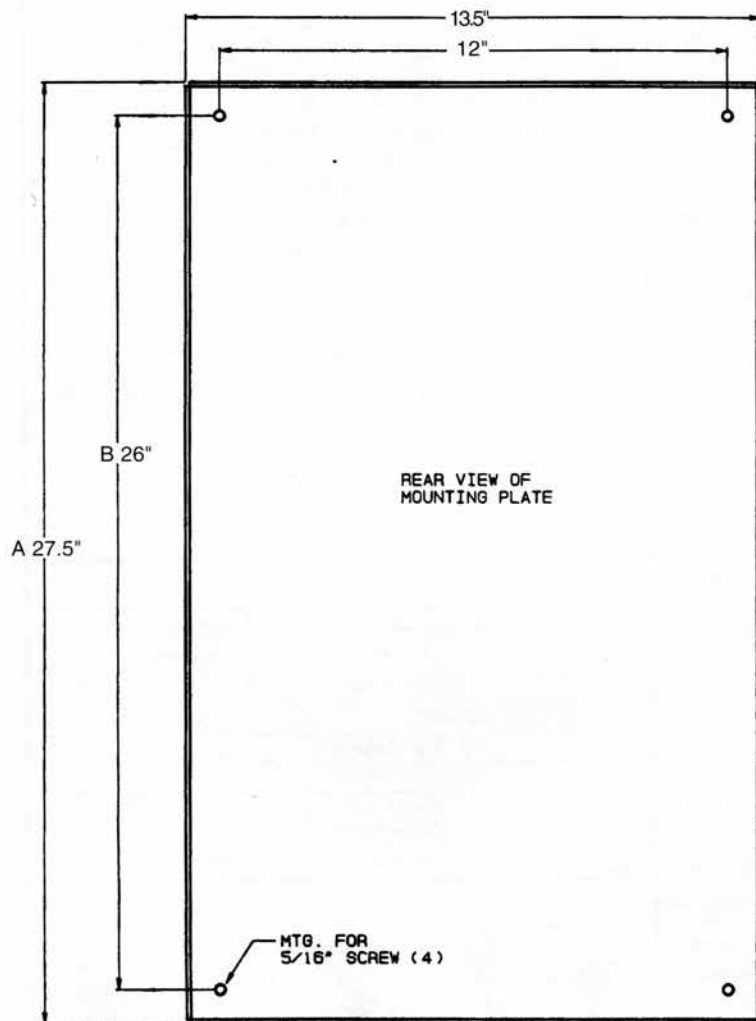

- 1 2.5/5.0/7.2 KV 200, 400A
2.5/5.0/7.2 KV 1200A 3 Phase
2.5/5.0/7.2 KV 1000, 1500A 2 Pole
2.5/5.0/7.2 KV 2000, 3000A 1 Pole

- 2 600 AMP
A = 32"
B = 30.5"

A

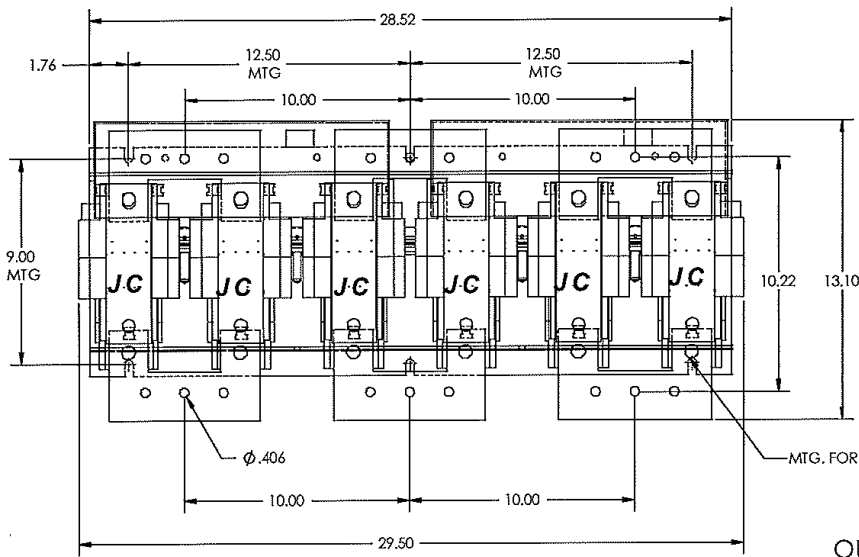
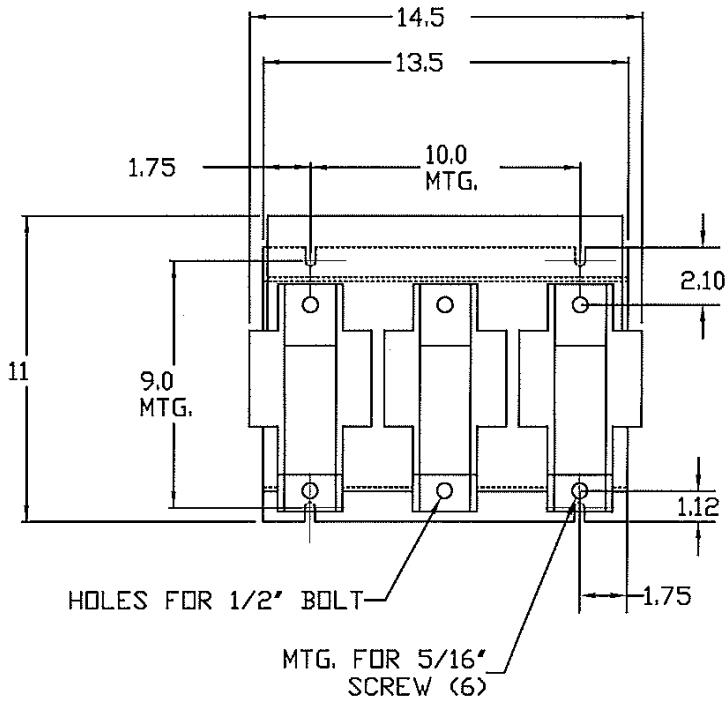

OUTLINE DRAWING

3 POLE CONTACTOR
800 & 1200 AMP - 2.5, 5.0 & 7.2 KV
1400 AMP - 600 V

USAVAC - MEDIUM VOLTAGE

Controllers

A

- UL 347 LISTED
- CSA 2-22 APPROVED
- FULL VOLTAGE
- NON REVERSING - REVERSING



Ampere Rating	Maximum HP Ratings	NEMA 12 Catalog No.
2300V VACUUM STARTERS With Fused Load Break Disconnect		
160*	100	MVS18TA31A25A-T236
160*	200	MVS18TA31A25B-T236
160*	400	MVS18TA31A25C-T236
200	900	MVS18TA32A25D-T236
200	1000	MVS18TA32A25E-T236
320*	1250	MVS18TA33A25F-T236
400	1500	MVS18TA35A25G-T236
600#	1750	MVS18TA36A25H-T236
600#	2000	MVS18TA36A25J-T236
600#	2250	MVS18TA36A25K-T236

Ampere Rating	Maximum HP Ratings	NEMA 12 Catalog No.
4160V VACUUM STARTERS With Fused Load Break Disconnect		
200	100	MVS18TA32A50A-T416
200	200	MVS18TA32A50B-T416
200	400	MVS18TA32A50C-T416
200	900	MVS18TA32A50D-T416
200	1000	MVS18TA32A50E-T416
200	1250	MVS18TA32A50F-T416
200	1500	MVS18TA32A50G-T416
400	1750	MVS18TA34A50H-T416
400	2000	MVS18TA34A50J-T416
400	2250	MVS18TA34A50K-T416
400	2500	MVS18TA34A50L-T416
400	3000	MVS18TA34A50M-T416
600#	3500	MVS18TA36A50N-T416
600#	4000	MVS18TA36A50P-T416
600#	4500	MVS18TA36A50R-T416

Ampere Rating	Maximum HP Ratings	NEMA 12 Catalog No.
6600V VACUUM STARTERS With Fused Load Break Disconnect		
200	100	MVS18TA32A72A-T666
200	200	MVS18TA32A72B-T666
200	400	MVS18TA32A72C-T666
200	900	MVS18TA32A72D-T666
200	1000	MVS18TA32A72E-T666
200	1250	MVS18TA32A72F-T666
200	1500	MVS18TA32A72G-T666
200	1750	MVS18TA32A72H-T666
200	2000	MVS18TA32A72J-T666
200	2250	MVS18TA32A72K-T666
200	2500	MVS18TA32A72L-T666
400	3000	MVS18TA34A72M-T666
400	3500	MVS18TA34A72N-T666
400	4000	MVS18TA34A72P-T666
400	4500	MVS18TA34A72R-T666
400	5000	MVS18TA34A72S-T666
600#	6000	MVS18TA36A72T-T666
600#	6750	MVS18TA36A72V-T666

Free Standing, Single High Compact Vacuum Starter in NEMA 12 Enclosures. Designed to comply with NEMA1CS2-324 Class E 2 controller.

Features Offered:

- Fault Make, Load break visible blade disconnect switch with automatic grounding arm.
- Grounded metal isolation between LV and Medium Voltage Compartments.
- Maintenance free Joslyn Clark Vacuum Contactors.
- Suitably rated current limiting power fuses with striker pins and 3 phase trip bar.
- C.P.T. provided with 2 primary and 1 secondary fuses, 120V secondary.

Ordering Information

- Engineering Data page A43.
- Modification Data page A49 & 50
- Renewal Parts page A36.

Notes:

For Reversing Applications and change 4th and 5th digit of cat # from 18 to 38.
 For Inching or Plugging Duty Refer to Factory.
 For Latched Contactors change "MVS" to "MVSL" - - & specify Trip Coil Voltage.
 * These Starters have 45KV BIL Rating if 60KV Required use 200A or 400A Rated Starters.
 For NEMA 3R Rating Change 5th Digit from "T" to "R"

Free standing, single high compact feeder capacitor. Feeder controller to comply with NEMA1CS2-324.

- Fault Make, Load break visible blade disconnect switch with automatic grounding arm.
- Grounded metal isolation between LV and Medium Voltage Compartments.
- Maintenance free Joslyn Clark Vacuum Contactors.
- Suitably rated current limiting power fuses with striker pins and 3 phase trip bar.
- C.P.T. provided with 2 primary and 1 secondary fuses, 120V secondary.



Ampere Rating	KVA Ratings	KVAR Rating	Catalog No.
2300V VACUUM STARTERS With Fused Load Break Disconnect			
200 AMP	750	550	MVF18TA32A25-T236
400 AMP	1500	1125	MVF18TA34A25-T236
600 AMP	2500	1650	MVF18TA36A25-T236
800 AMP	2750	2200	MVF18TA38A25-T236
1200 AMP	4100	2750	MVF18TA312A25-T236

Ampere Rating	KVA Ratings	KVAR Rating	Catalog No.
4160V VACUUM STARTERS With Fused Load Break Disconnect			
200 AMP	1500	1050	MVF18TA32A50-T416
400 AMP	3000	2250	MVF18TA34A50-T416
600 AMP	4250	3375	MVF18TA36A50-T416
800 AMP	5250	4500	MVF18TA38A50-T416
1200 AMP	7000	5625	MVF18TA312A50-T416

Ampere Rating	KVA Ratings	KVAR Rating	Catalog No.
7200V VACUUM STARTERS With Fused Load Break Disconnect			
200 AMP	2000	1500	MVF18TA32A72-T666
400 AMP	4000	3000	MVF18TA34A72-T666
600 AMP	6000	4500	MVF18TA36A72-T666
800 AMP	7500	5000	MVF18TA38A72-T666

- Transformer ratings assume 100% continuous rating for operation at overload ratings Consult Factory
- For latched contactors change "MVF" to "MVFL" add to specify trip coil voltage.

USAVAC - MEDIUM VOLTAGE

Controllers

NON REVERSING CLOSED TRANSITION

UL 347 LISTED

CSA 2-22 APPROVED

A

Designed for automatic starting of Squirrel Cage Motors when the starting current or torque must be reduced. Joslyn Clark Reduced Voltage Auto Transformer Starters incorporate equipment exactly as the full voltage starters, with the additional following equipment

- 1- Free Standing Cubicle Containing:
 - 1- 3 Pole Starting Vacuum Contactor
 - 1- 3 Pole Shorting Vacuum Contactor
 - 1- Set of Mechanical Interlocks
 - 1- 3-Coil Auto -Transformer with 50-65-80% taps.
 - 1- Incomplete Sequence Timer



2300V RVAT Starters With Fused Motor Load Break Disconnect				
Max HP	Cat # NEMA 12		Max HP	Cat # NEMA 12
*100	MVS83TA31A25A-T236		*1250	MVS83TA33A25F-T236
*200	MVS83TA31A25B-T236		1500	MVS83TA34A25G-T236
*400	MVS83TA31A25C-T236		1750	MVS83TA36A25H-T236
*900	MVS83TA33A25D-T236		2000	MVS83TA36A25J-T236
*1000	MVS83TA33A25E-T236		2250	MVS83TA36A25K-T236
4160V RVAT Starters With Fused Motor Load Break Disconnect				
100	MVS83TA32A50A-T416		2000	MVS83TA34A50J-T416
200	MVS83TA32A50B-T416		2250	MVS83TA34A50K-T416
400	MVS83TA32A50C-T416		2500	MVS83TA34A50L-T416
900	MVS83TA32A50D-T416		3000	MVS83TA34A50M-T416
1000	MVS83TA32A50E-T416		3500	MVS83TA36A50N-T416
1250	MVS83TA32A50F-T416		4000	MVS83TA36A50P-T416
1500	MVS83TA32A50G-T416		4500	MVS83TA36A50R-T416
1750	MVS83TA34A50H-T416			
6600V RVAT Starter With Fused Motor Load Break Disconnect				
1000	MVS83TA32A72E-T666		4000	MVS83TA34A72P-T666
1500	MVS83TA32A72G-T666		5000	MVS83TA34A72S-T666
2000	MVS83TA32A72J-T666		6000	MVS83TA36A72T-T666
2500	MVS83TA32A72L-T666		6750	MVS83TA36A72V-T666
3000	MVS83TA34A72M-T666			

Notes:

- For NEMA 3R Replace 6th cat. # digit 'T' with 'R'
- * These Starters have 45KV BIL Rating for, 60KV Rating
- For reversing application change the 83 to 86.
- For inching or plugging duty refer to Factory.

USAVAC - MEDIUM VOLTAGE

Controller Modifications

A

Modifications For Combination USAVAC Medium Voltage Controllers

Description	Enclosed Type NEMA 1, 3R, 12	Change Cat. No. Character Indicated To:	Typical Catalog Number	
Cover Controls				
Push Buttons & Selector Switches Hand-Off-Auto Selector Switch		B		
Start-Stop Push Buttons		C		
2 or 3 Position Selector Switch - SPDT		B		
Forward-Reverse-Stop Push Buttons		C		
Pilot Lights With Electrical Interlock: Standard Transformer Type, Red Lens		13		
Push-to-Test Transformer Type, Red Lens		14		
Modification 11-14. Lens color below. Example: Order 11 + 15 = Std. Transformer with interlock & color lens				
Example	Green	13+15		
	Blue	13+16		
Pilot Light Red Lens -13	White	13+17		
Pilot Light Green Lens -(13 + 15)	Yellow	13+18		
	Amber	13+19		
	Clear	13+20		
Auxiliary Relays				
Extra 2 N, 0 & 2 N.C. Aux. Contacts		21		
Time Relay ON Delay		22		
Time Relay OFF Delay		23		
Time Relay ON Delay & Instantaneous		24		
Time Relay OFF Delay & Instantaneous		25		
Time Relay ON Delay & OFF Delay		26		
Overload Relays				
7777 Electronic Motor Management Relay • (Includes Ground Fault Protection) No RTD Protected		27		
• RM 2000 Motor Monitor (for use with 777 Relay) Option 27		27A		
• 369+ Motor Management Relay Current Only		31A		
• 369+ Motor Management Relay Current & Voltage		31B		
• 469 + Motor Management Relay Drawout Case		30		
• PQM Power Quality Meter		29		
• Transformer Feeder Relay 745		62		
Includes C/TS & P/T's				
Incoming & Auxiliary Cubicle Options				
18" Cable Pull Section		54		
24" Cable Pull Section (use with option #29)		55		
400A Incoming Section Unit Unfused		56		
400A Incoming Section Unit Fused		57		
600A Incoming Section Unit Unfused		58		
600A Incoming Section Unit Fused		59		
1200A Incoming Section Unit Unfused		60		
1200A Incoming Section Unit Fused		61		

USAVAC - MEDIUM VOLTAGE

Controller Modifications

A

Description	Change Cat. No. Character Indicated To:	Typical Catalog Number
No Overload Relay	28	MV S18T A 32A25-T236-
Overload Relay with N.O & N.C Contact	28A	
Fused for Separate Control	32	
Voltage Monitor Relay	33	
3 Phase Voltage Monitor Relay, Phase loss, Phase Reversal	33A	
Ammeter and Current Transformer	34	
Ammeter, Switch and 3 Current Trans.	35	
Voltmeter	36	
Voltmeter and Switch	37	
Elapsed Time Meter	38	
Wattmeter	39	
Watt-hour Meter	40	
Operations Counter 8 digit	41	
Space Heater	42	
Mechanically Interlocked Contactors	43	
Zero Sequence Ground Fault Relay	44	
Lightning Protector	45	
Lightning Surge Protector		
Overhead Bus 800A/Cubicle (24" Length)	47	
Overhead Bus 1200A/Cubicle (24" Length)	48	
Surge Capacitor	46	
Overhead Bus 1600A/Cubicle (24" Length)	49	
* A ground Bus is included in busbar		
Overhead Bus 800A (36" Length) 30 or 36	50	
Overhead Bus 1200A (36" Length) 30 or 36	51	
Overhead Bus 1600A (36" Length) 30 or 36	52	
Digital Power Meter (DPM) is available but not UL approved	35A	

DPM includes
 Ammeter 3 Phase
 Voltmeter 3 Phase
 Power (kw) Wattmeter
 Energy (KWH) Meter
 PF Meter
 Frequency Meter
 Reactive Meter (KVAR)

Ordering Example:

MVS18TA32A25B-T236 with the following modifications

1 - 3 Phase Voltage Monitor Relay, Phase loss, Phase reversal.....	33A
1- Operations Counter 8 Digit.....	41
Digital Power Meter	35A
1-777 Electronic Motor Management Relay.....	27
1-Rm 2000 Motor Monitor	27A

Complete Cat. # is MVS18TA32A25B-T236-33A-41-27-27A

Ordering Example:

MVS18TA32A25A-T236 with the following modifications:

1 - Hand-Off-Auto Selector Switch	B
1- Transformer operated Red Pilot with Interlock	13
1- Transformer operated Green Pilot with Interlock	(13 + 15)

Complete Cat. # is MVS18TB32A25A-T236-13-(13+15)

NEMA CONTROL

Contactors & Starters Index



Description	Page Number
General Information - TM.....	B2
AC Magnetic Contactors - TM.....	B5
AC Magnetic Reversing Contactors - TM.....	B6
AC Magnetic Starters - TM.....	B7
AC Magnetic Reversing Starters - TM.....	B8
AC Magnetic Two Speed Starters - TM.....	B9 - B10
AC Magnetic Reduced Voltage A/T Starters - TM.....	B11
AC Panel Mounted Overload Relay.....	B12
Heater Tables, TM, HP Starter.....	B13 - B16
Factory Modifications - TM.....	B17
Field Modifications - TM.....	B18 - B19
Renewal Parts - TM.....	B20 - B21
Dimensions - TM.....	B22 - B25
Engineering Data - Diagrams.....	B26 - B31
Catalog Ordering Data.....	B32
Series 5000 AC NEMA Rated Contactors.....	B35 - B37

TM - NEMA CONTROL

General Information

B

Auxiliary Contacts - Auxiliary contact blocks may be added with the starter in place, without tools. The same block is used on sizes 00 thru size 4 as either N.O. or N.C.. A total of 4 auxiliary contacts can be added. The addition of side mounting kits allows a total of 8 auxiliary contacts through size 4.

Power Pole - Full rated power poles, N.O. or N.C. through NEMA size 4, may be field added, without coil change. A tie pole with 2 N.O. contacts is available for two-speed single winding (consequent pole) motor applications.

Adapter Plate - Allows use of Type TM starters in place of other makes thru size 2, without drilling new mounting holes. The adapter plate holes align with those of most other starters thru size 2 - proof of the TM compact design.

Reliability - The basic contactor design, using polysulphone and teflon guides, melamine and rosite moldings along with stainless steel springs, provides exceptional electrical and mechanical life. The operating state is clearly visible from the front, indicated by the position of the contact carrier. The contactor is easily operated from the front for circuit checking.



Operating Coils - All coils are encapsulated. Size 00 thru 4 are plug-in type and each is factory tested twice, for long reliable service. Coil changes are not required for any combination of add-on accessories.

Power Wiring - Up-front terminals and straight through design make power wiring easy. As few as 3 connection points per pole reduces the possibility of loose connections and contributes to the reliability of the starter.

Contact Inspection - Loosen 2 captive screws and remove the contact carrier, through size 4.

Overload Relay - Available with ambient compensation (green reset rod) or non-ambient compensation (red reset rod). An easily accessible + 15, adjustment knob can be locked at the 100% setting. High accuracy of repetitive trip is assured by factory testing every unit twice.

Heaters - Heater numbers are stamped on the surface for easy identification. The same heaters are used for TM & HP series overload relays for both ambient and non-ambient compensated overload relays.

Versatility - Uniform mounting dimensions; Add-on auxiliary contacts; Plug-in coils Accessories, such as power pole, mechanical interlock provides maximum versatility and flexibility of inventory panel layout and installation. Self-rising saddle-clamps are included on all control terminals for quick wiring.



Compact Size - Integral overload relay design, with straight through power cable design, provides compact overall size. Straight through wiring reduces overall panel area for a NEMA wired device.

Uniform Mounting Dimensions - Along with mechanical interlock design, make reversing devices and other mechanically interlock devices the same height and depth as non reversing. This allows intermixing in rows and saves panel space.

Uniform Mounting Dimensions - Only 2 mounting plate sizes for 00 through 4 starters. One mounting plate for sizes 00-2, the second for sizes 3 & 4. This provides great flexibility for intermixing starter sizes in rows and reduces panel layout time.

Pilot Device Kits - Operator devices may be added in the field. Push button and pilot light kits for non-combination enclosures are suitable for use in NEMA Type 1, 4 & 12. This simplifies selection and increases flexibility.

TM - NEMA CONTROL

General Information

Non-Reversing

- Bulletin 6013 NEMA Starters.
- Bulletin 7707 NEMA Contactors.
- NEMA Size 00-6.
- NEMA Type 1, 4 & 12 Enclosures.
- NEMA Size 00-2.
- NEMA Type 3R Enclosure.
- Bulletin 6013 Starters are available single phase through size 2P, 3 phase through size 6.
- Bulletin 7707 Contactors are available 2 & 3 pole through size 6 and 4 pole through size 4.



Reversing

- Bulletin 6030 NEMA Starters.
- Bulletin 6031 NEMA Contactors.
- NEMA Size 00-6.
- NEMA Type 1, 4, 12 Enclosures
- Bulletin 6030 reversing starters and Bulletin 6031 reversing contactors include mechanical and electrical interlocks. Bulletin 7707 Contactors are available 2 & 3 pole through size 6 and 4 pole thru size 4.

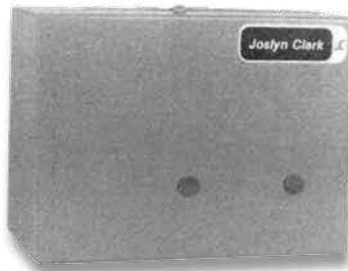

Multi-Speed

- Bulletin 6050 NEMA Starters.
- NEMA Size 0-5.
- NEMA Type 1, 4 & 12 Enclosures.
- Bulletin 6050 multi-speed starters are designed for two-speed, single winding (consequent pole) and two-speed, two winding (separate winding) motor applications.
- Mechanical and electrical interlocks are included.
- Starters for three and four speed motor applications can also be supplied.



B



B

AC Contactors - Bulletin 7707 TM

1-Pole, Single Phase								
NEMA Size	Maximum Motor Horsepower Rating			Starter Amps. Continuous	NEMA Type 1 General Purpose Enclosure Catalog No. ¹	NEMA Type 12 Industrial - Dust-tight Enclosure Catalog No. ¹	Open Type Catalog No. ¹	
	115V	200V	230V					
	1/3	----	1	9	T77A01A -*	Use Size 0	T77U01A -*	
	1	----	2	18	T77A010 -*	T77T010 -*	T77U010 -*	
	2	----	3	27	T77A011 -*	T77T011 -*	T77U011 -*	
2 Pole, Single Phase								
00	1/3	----	1	9	T77A02A -*	Use Size 0	T77U02A -*	
0	1	----	2	18	T77A020 -*	T77T020 -*	T77U020 -*	
1	2	----	3	27	T77A021 -*	T77T021 -*	T77U021 -*	
2	3	----	7½	45	T77A022 -*	T77T022 -*	T77U022 -*	
3	7½	----	15	90	T77A023 -*	T77T023 -*	T77U023 -*	
3 Pole, Three Phase								
NEMA Size	200V	230V	460-575V	Continuous				
00	1½	1½	2	9	T77A03A -*	Use Size 0	T77U03A -*	
0	3	3	5	18	T77A030 -*	T77T030 -*	T77U030 -*	
1	7½	7½	10	27	T77A031 -*	T77T031 -*	T77U031 -*	
2	10	15	25	45	T77A032 -*	T77T032 -*	T77U032 -*	
4	40	50	100	135	T77A034 -*	T77T034 -*	T77U034 -*	
5	75	100	200	270	See Vacuum Contactors in Section A			
6	150	200	400	540				

Notes:

1. Includes contactor complete with one N.O. control-circuit contact.
2. This unit replaces T77 (size 5) and is not interchangeable.

Ordering Information

- Use complete catalog number when ordering. Replace the (*) with the suffix from the coil table.
- Modifications page B36
- Engineering Data page B50.
- Renewal Parts page B42.
- Dimensions page B43.

Coil Volt/Hertz	Suffix
24/60 or 24/50	-96
110-120/60 or 110/50	-76
220-240/60 or 220/50	-26
440-480/60 or 440/50	-46
550-600/60 or 550/50	-56
200-208/60	-86

TM - NEMA CONTROL

AC Reversing Contactors



B

AC Reversing Contactors - Bulletin 6031 TM

NEMA Size	Maximum Motor ² Horsepower Rating			NEMA Type 1 General Purpose Enclosure Catalog No. ¹	NEMA Type 12 Industrial - Dust-tight Enclosure Catalog No. ¹	Open Type Catalog No. ¹
	200V	230V	460-575V			
00	1½	1½	2	T31A03A -*	Use Size 0	T31U03A -*
0	3	3	5	T31A030 -*	T31T030 -*	T31U030 -*
1	7½	7½	10	T31A031 -*	T31T031 -*	T31U031 -*
2	10	15	25	T31A032 -*	T31T032 -*	T31U032 -*
4	40	50	100	T31A034 -*	T31T034 -*	T31U034 -*
5 ²	75	100	200	See Vacuum Contactors in Section A		
6	150	200	400			

Plug-Stop or Jogging Duty NEMA ICS 2-321-3

NEMA Size	Horsepower Ratings - Three Phase, 60Hz			
	200V	230V	380V	460/575V
0	1½	1½	1½	2
1	3	3	5	5
2	7½	7½	15	15
3	15	15	30	30
4	25	30	50	60
5	60	75	125	150
6	125	10\50	250	300

Ordering Information

- Use complete catalog number when ordering. Replace the (*) with the suffix from the coil table.
- Modifications page B36
- Engineering Data page B50.
- Renewal Parts page B42.
- Dimensions page B43.

Coil Volt/Hertz	Suffix
24/60 or 24/50	-96
110-120/60 or 110/50	-76
220-240/60 or 220/50	-26
440-480/60 or 440/50	-46
550-600/60 or 550/50	-56
200-208/60	-86

Notes:

1. Price includes contactor complete with one N.O. contact on each contactor. All contactors are mechanically and electrically interlocked.
2. For plug-stop or jogging duty, where operations exceed 5 times a minute, contactor size should be chosen in accordance with NEMA Standard ICS 2-321-3, as listed in table.

TM - NEMA CONTROL

AC Non-Reversing Starters

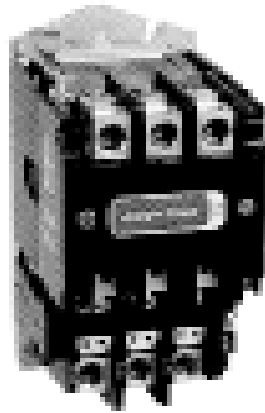

B

AC Non-Reversing Starters - Bulletin 6013 TM

2 Pole, Single Phase (requires 1 overload heater)							
NEMA Size	Maximum Motor Horsepower Rating				NEMA Type 1 General Purpose Enclosure Catalog No. ¹	NEMA Type 12 Industrial - Dust-tight Enclosure Catalog No. ¹	Open Type Catalog No. ¹
	115V	200V	230V	Contin-uous			
00	1/3	----	1	9	T13AA2A -*	Use Size 0	T13U02A -*
0	1	----	2	18	T13AA20 -*	T13TA20 -*	T13U020 -*
1	2	----	3	27	T13AA21 -*	T13TA21 -*	T13U021 -*
1P	3	----	5	----	T13AA2P -*	T13TA2P -*	T13U02P -*
2	3	----	7½	45	-----	-----	T13U022 -*
3 Pole, Three Phase (requires 3 overload heaters)							
NEMA Size	Maximum Motor Horsepower Rating			Contin-uous			
	200V	230V	460-575V				
00	1	1	2	9	T13AA3A -*	Use Size 0	T13U03A -*
0	3	3	5	18	T13AA30 -*	T13TA30 -*	T13U030 -*
1	7	7	10	27	T13AA31 -*	T13TA31 -*	T13U031 -*
2	10	15	25	45	T13AA32 -*	T13TA32 -*	T13U032 -*
4	40	50	100	135	T13AA34 -*	T13TA34 -*	T13U034 -*
5	75	100	200	270			
6	150	200	400	540			

See Vacuum Contactors in Section A

Notes:

1. Includes starter complete with one N.O. contact on each contactor and 3 phase overload relay less heaters.
2. For Ambient Compensated overload see B37.

Ordering Information

- Use complete catalog number when ordering. Replace the (*) with the suffix from the coil table.
- Modifications page B18.
- Engineering Data page B26.
- Renewal Parts page B21.
- Dimensions page B22.

Coil Volt/Hertz	Suffix
24/60 or 24/50	-96
110-120/60 or 110/50	-76
220-240/60 or 220/50	-26
440-480/60 or 440/50	-46
550-600/60 or 550/50	-56
200-208/60	-86

TM - NEMA CONTROL

AC Reversing Starters



B

AC Reversing Starters - Bulletin 6030 TM

NEMA Size	Maximum Motor ² Horsepower Rating			NEMA Type 1 General Purpose Enclosure Catalog No. ¹	NEMA Type 12 Industrial - Dust-tight Enclosure Catalog No. ¹	Open Type Catalog No. ¹
	200V	230V	460-575V			
00	1½	1½	2	T30AA3A -*	Use Size 0	T30U03A -*
0	3	3	5	T30AA30 -*		T30TA30 -*
1	7½	7½	10	T30AA31 -*	T30TA31 -*	T30U031 -*
2	10	15	25	T30AA32 -*	T30TA32 -*	T30U032 -*
4	40	50	100	T30AA34 -*	T30TA34 -*	T30U034 -*
5	75	100	200	See Vacuum Contactors in Section A		
6	150	200	400			

Notes:

1. Includes starter complete with one N.O. contact on each contactor and 3 phase overload relay less heaters. All starters are mechanically and electrically interlocked.
2. For plug-stop or jogging duty or where operations exceed 5 per minute, starter sizes should be chosen in accordance with NEMA Standard ICS 2-321-3, as listed in table.
3. For Ambient Compensated overload see B37.

Plug-Stop or Jogging Duty NEMA ICS 2-321-3

NEMA Size	Horsepower Ratings - Three Phase, 60Hz			
	200V 60 Hz	230V 60 Hz	380V 50 Hz	460/575V 60 Hz
0	1½	1½	1½	2
1	3	3	5	5
2	7½	7½	15	15
3	15	15	30	30
4	25	30	50	60
5	60	75	125	150
6	125	10\50	250	300

Ordering Information

- Use complete catalog number when ordering. Replace the (*) with the suffix from the coil table.
- Engineering Data page B26.
- Modifications page B18.
- Heater Tables page B15.
- Renewal Parts page B21.
- Dimensions page B22.

Coil Volt/Hertz	Suffix
24/60 or 24/50	-96
110-120/60 or 110/50	-76
220-240/60 or 220/50	-26
440-480/60 or 440/50	-46
550-600/60 or 550/50	-56
200-208/60	-86



AC Two Speed Non Combination Starters - Bulletin 6050

NEMA Size	Maximum Motor Horse Power Rating Constant or Variable Torque (Constant Horsepower)			NEMA 1 General Purpose Enclosure	NEMA 12 Industrial - Dust-tight Enclosure	Open Type
2 Speed, Double Winding (separate winding)						
0	3 (2)	3 (2)	5 (3)	T50AA0S2 -*	T50TA0S2 -*	T50U00S2 -*
1	7 ½ (50)	7 ½ (5)	10 (7½)	T50AA1S2 -*	T50TA1S2 -*	T50U01S2 -*
2	10 (7½)	15 (10)	25 (20)	T50AA2S2 -*	T50TA2S2 -*	T50U02S2 -*
3	25 (20)	30 (20)	50 (40)	T50AA3S2 -*	T50TA3S2 -*	T50U03S2 -*
4	40 (30)	50 (40)	100 (75)	T50AA4S2 -*	T50TA4S2 -*	T50U04S2 -*
5	75 (60)	100 (75)	200 (150)	Consult Factory		

Notes:

1. Includes starter complete with one N.O. contact on each contactor and two 3 phase overload relays less heaters. All starters are mechanically and electrically interlocked. Six (6) heaters are required, 3 for each speed rated for HP ratings.

Ordering Information

- Use complete catalog number when ordering. Replace the (*) with the suffix from the coil table.
- Engineering Data page B26.
- Modifications page B18.
- Heater Tables page B14 & B15.
- Renewal Parts page B21.
- Dimensions page B22.

Coil Volt/Hertz	Suffix
24/60 or 24/50	-96
110-120/60 or 110/50	-76
220-240/60 or 220/50	-26
440-480/60 or 440/50	-46
550-600/60 or 550/50	-56
200-208/60	-86

B

TM - NEMA CONTROL

AC Reduced Voltage Starters

Autotransformer Closed Transition

- Reduced Voltage Starting of Squirrel Cage Motors
- Highest Starting Torque per Ampere of Line Current
- Available in Type 4 & 12 Enclosure
- All Disconnect Types Available
- Complete Line Factory Installed Modifications

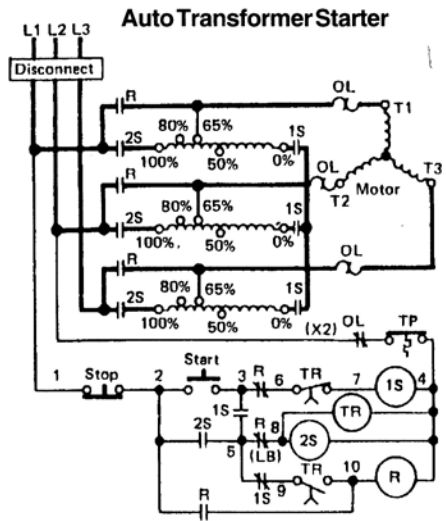

Part Winding Starters

- Two Step Starting of Squirrel Cage Motors
- Lowest Cost Method of Starting
- NEMA Type 1, 4, & 12 Enclosures
- Factory Installed Modifications

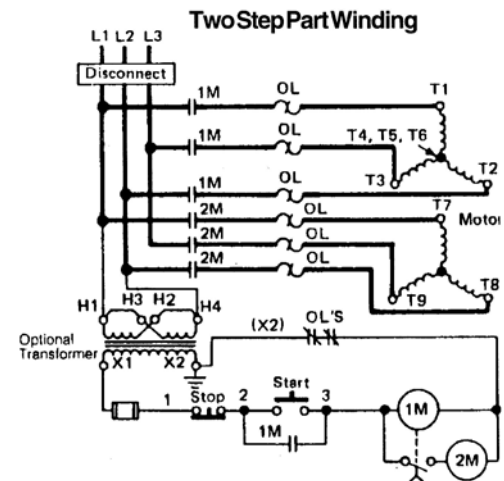

Wye-Delta Starters

- Available Open or Closed Transition
- Inrush Current 1/3 Normal Line Starting
- NEMA 1 Enclosure Standard

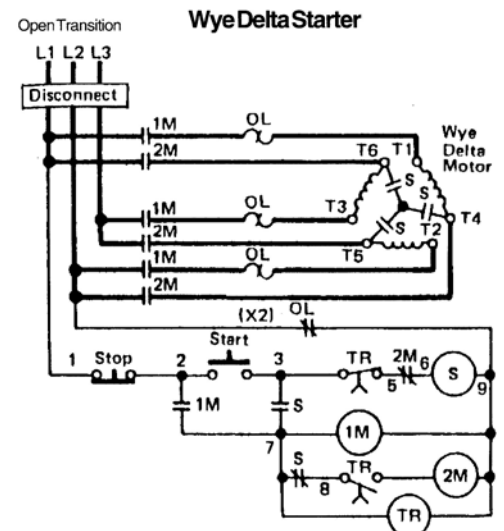

B

Autotransformer Closed Transition - Bulletin 6082

NEMA Size	Max. Motor Horsepower Rating ¹		NEMA Type 1 General Purpose ²
	230V	460V	Catalog No.
3	25	-----	T82AA3FB
	30	-----	T82AA3GB
	-----	30	T82AA3GE
	-----	50	T82AAJE
4	50	-----	T82AAJB
	-----	100	T82AAME
5	75	-----	U2AA5LB
	100	-----	U82AA5MB
	-----	150	U82AA5PE
	-----	200	T82AA5QE
6	125	-----	Refer to Section A
	150	-----	
	200	-----	
	-----	250	
	-----	300	
	-----	400	

Ordering Information

- Use complete catalog number when ordering. Replace the (*) with the suffix from the coil table.
- Engineering Data page B26.
- Modifications page B18.
- Renewal Parts page B21.

Coil Volt/Hertz	Suffix
220-240/60 or 220/50	-26
440-480/60 or 440/50	-46

B

Notes:

1. Maximum horsepower ratings are in accordance with NEMA Standards ICS2-321C:20. Auto transformers are 3-Coil type, with voltage taps at 50%, 65% and 80% rated in accordance with NEMA Standards ICS2-214.21 for medium-duty starting service.
2. Size 5 Starters are supplied in floor mounted enclosures without bottom cover plate for mounting against a wall. If not mounted against a wall, a rear cover plate must be ordered.
3. Wye-Delta Starters Overload Relay Heater Selected by dividing FLC by 1.73 and select Heaters from index.

TM - NEMA CONTROL

Thermal Overload Relays

Free Standing Panel Mount

Catalog Numbers Bulletin 7324

Overload Relay	Normally Closed Contacts	Normally Open & Normally Closed Contacts
Size	Catalog No. ¹	Catalog No. ¹

Standard Bimetallic Overload Relays

1 -30AMP	KTM31-12	KTM31-13
2 -50AMP	KTM32-12	KTM32-13

Ambient Compensated Bimetallic Overload Relays

1 -30AMP	KTMA31-12	KTMA31-13
2 -50AMP	KTMA32-12	KTMA32-13

1. Includes 3 - Phase Overload Relay complete, less heaters.

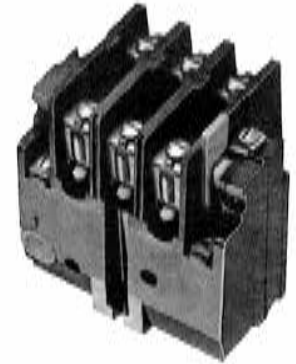

B

Single Phase Application

A three phase overload relay is used for single phase applications. Only one heater is required and is to be installed in the center phase cavity of the relay.

Heater Selection

Select heaters based on motor nameplate full-load current. Tables are for continuous rated motors. Full-load current for a given horsepower motor will vary from one manufacturer to another and will depend on RPM of motor.

Type Of Protection

Heaters selected directly from the table provide a maximum of 125% protection at 40°C degree ambient, is suitable for motors with a 1.15 service factor with a 40°C degree rise or less and with motor and controller at the same temperature.

For motors with a 1.0 service factor or with a temperature rise greater than 40°C degree without service factor rating, use one size smaller heaters than in table. The ultimate trip of the heater is approximately 125% of the minimum current shown in the tables in a 40°C degree ambient.

Ambient Correction

Not necessary when overload relay is ambient compensated as identified by green reset rod. For control at an ambient constantly less than the motor ambient, correct by decreasing the nameplate motor full-load current by 1% per °C difference in ambient for heater selection.

For control at an ambient constantly greater than the motor ambient, correct by increasing the nameplate motor full-load current by 1% per °C difference in ambient.

Branch Circuit Protection

Branch circuit protection should be provided per National Electric Code (USA) or the Canadian Standards Association rules.

Automatic Reset

Automatic reset operation should not be used with two-wire control.

Overload Adjustment

These overload relays are manufactured with an exclusive calibration process to assure the ultimate in tripping accuracy and repeatability. The overload allows a true $\pm 15\%$ adjustment as a result of the process and is well suited for use with unity service factor motors requiring a shorter locked rotor tripping time. The $\pm 15\%$ adjustment is easily made by means of a small dial on the bottom of the relay. A quick field modification also permits removal of the adjustment feature.

TM - NEMA CONTROL

Thermal Overload Relays

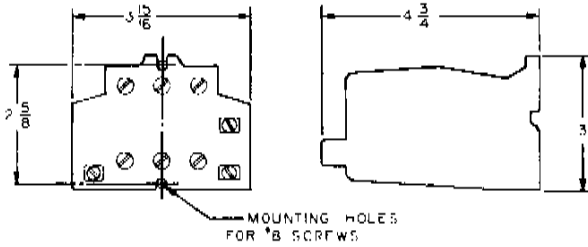

Bulletin 7324 Type TM Bimetallic Overload Relay 30 & 50 Ampere, Panel Mounting

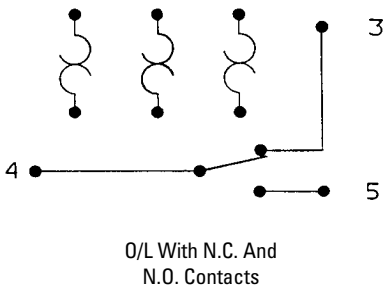
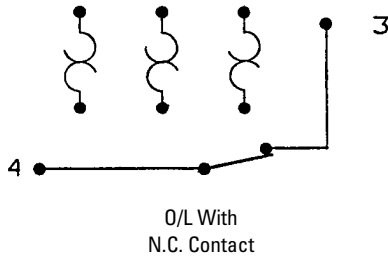

Free Standing Panel Mounted Sizes 1 & 2-Type TM Bimetallic Standard and Ambient Compensated

Single Phase Heater Catalog Number	Motor Ampere Rating				Overload Relay Size
	Three Phase One Heater		3 Heaters		
	Min.	Max.	Min.	Max.	
2411	.58	.62	.46	.51	1 2
2412	.63	.68	.52	.56	
2413	.69	.78	.57	.62	
2414	.79	.88	.63	.70	
2415	.89	.98	.71	.77	
2416	.98	1.07	.78	.85	
2417	1.08	1.21	.86	.96	
2418	1.22	1.29	.97	1.02	
2419	1.30	1.41	1.03	1.12	
2420	1.42	1.49	1.13	1.18	
2421	1.50	1.68	1.19	1.33	
2422	1.69	1.91	1.34	1.51	
2423	1.92	2.15	1.52	1.70	
2424	2.16	2.49	1.71	1.97	
2425	2.50	2.71	1.98	2.15	
2426	2.72	2.99	2.16	2.37	
2427	3.00	3.37	2.38	2.67	
2429	3.38	3.67	2.68	2.89	
2430	3.68	4.09	2.90	3.24	
2431	4.10	4.53	3.25	3.51	
2432	4.54	4.92	3.52	3.90	
2433	4.93	5.30	3.91	4.25	
2434	5.31	6.14	4.26	4.87	
2435	6.15	6.89	4.88	5.48	
2436	6.90	7.64	5.49	6.05	
2437	7.65	8.19	6.06	6.50	
2438	8.20	9.29	6.51	7.38	
2439	9.30	10.1	7.39	8.07	
2441	10.2	10.7	8.08	8.55	
2442	10.8	11.7	8.56	9.34	
2443	11.8	12.6	9.35	10.0	
2444	12.7	14.0	10.1	11.1	
2445	14.1	16.2	11.2	12.8	
2446	16.3	18.0	12.9	14.3	
2447	18.1	20.7	14.4	16.4	
2448	20.8	23.3	16.5	18.5	
2450	23.4	25.4	18.6	20.0	
2451	25.4	27.9	20.1	22.1	
2452	28.0	32.9	22.2	26.1	
2453	33.0	35.9	26.2	28.4	
2454	36.0	40.6	28.5	30.0	
2453	33.0	35.9	-	-	
2454	36.0	40.6	28.5	32.2	
2455	40.7	45.5	32.3	36.1	
2456	45.6	52.3	36.2	41.4	
2457	52.4	58.0	41.5	47.9	
2459	-	-	48.0	50.0	

Overload Relay Contact Ratings-Type TM

NEMA Size	Contact	Volts, AC	Continuous Amperes	A-C Inductive (0.35 pf)	
				Make	Break
00-6	N.C.	120V or less 120-600 V	2.5	15A 1800VA	1.5A 180VA
	N.O.	120V or less 120-600V		3A 360 VA	.3A 36 VA

B

TM - NEMA CONTROL

Overload Heater Data

Type of Protection

Heaters selected directly from the table provide a maximum of 125% protection at 40°C degree ambient, is suitable for motors with a 1.15 service factor with a 40°C degree rise or less and with motor and controller at the same temperature. For motors with a 1.0 service factor or with a temperature rise greater than 40°C degree without service factor rating, use one size smaller heaters than in table. The ultimate trip of the heater is approximately 125% of the minimum current shown in the tables in a 40°C degree ambient.

Ambient Correction

Not necessary when overload relay is ambient compensated as identified by green reset rod. For control at an ambient constantly less than the motor ambient, correct by decreasing the nameplate motor full-load current by 1% per °C degree difference in ambient. For control at an ambient constantly greater than the motor ambient, correct by increasing the nameplate motor full-load current by 1% per °C degree difference in ambient.

Automatic Reset

Automatic reset operation should not be used with two-wire control.

Heater Selection

Select heaters based on motor nameplate full-load current. Tables are for continuous rated motors. Full-load current for a given horsepower motor will vary from one manufacturer to another and will depend on RPM of motor.

B

Single Phase - Size 00, 0, 1, 1P, 2				
Motor Ampere Rating - Type TM, HP				
Open Starter Bimetallic Relay		Heater Catalog Number	Enclosed Starter Non-Ambient and Open or Enclosed Starters Ambient Compensated Relay	
Min.	Max.		Min.	Max.
.55	.59	2411	.53	.57
.60	.65	2412	.58	.63
.66	.69	2413	.64	.67
.70	.77	2414	.68	.75
.78	.84	2415	.76	.82
.85	.96	2416	.83	.93
.97	1.06	2417	.94	1.03
1.07	1.14	2418	1.04	1.11
1.15	1.29	2419	1.12	1.25
1.30	1.37	2420	1.26	1.33
1.38	1.47	2421	1.34	1.43
1.48	1.68	2422	1.44	1.63
1.69	1.93	2423	1.64	1.87
1.94	2.17	2424	1.88	2.11
2.18	2.38	2425	2.12	2.31
2.39	2.63	2426	2.32	2.55
2.64	2.96	2427	2.56	2.87
2.97	3.20	2429	2.88	3.11
3.21	3.57	2430	3.12	3.47
3.58	3.90	2431	3.48	3.79
3.91	4.27	2432	3.80	4.15
4.28	4.52	2433	4.16	4.39
4.53	5.10	2434	4.40	4.95
5.11	5.50	2435	4.96	5.34
5.51	5.92	2436	5.35	5.75
5.93	6.58	2437	5.76	6.39
6.59	7.24	2438	6.40	7.03
7.25	8.23	2439	7.04	7.99
8.24	9.05	2441	8.00	8.79
9.06	10.00	2442	8.80	9.75
10.10	10.60	2443	9.76	10.3
10.70	12.30	2444	10.4	11.9
12.40	13.40	2445	12.0	13.0
13.50	14.70	2446	13.1	14.3
14.80	16.80	2447	14.4	16.3
16.90	19.30	2448	16.4	18.7
19.40	21.10	2450	18.8	20.5
21.20	24.20	2451	20.6	23.5
24.30	25.90	2452	23.6	25.0
26.00	28.50	2453	25.0	27.1
28.60	33.80	2454	27.2	31.9
33.90	37.90	2455	23.0	35.9
38.00	40.00	2456	36.0	38.9
		2457	39.0	40.0

Three Phase - Size 00, 0, 1, 1P, 2				
Motor Ampere Rating - Type TM, HP				
Open Starter Bimetallic Relay		Heater Catalog Number	Enclosed Starter Non-Ambient and Open or Enclosed Starters Ambient Compensated Relay	
Min.	Max.		Min.	Max.
.44	.48	2411	.42	.46
.49	.54	2412	.47	.51
.55	.59	2413	.52	.56
.60	.67	2414	.57	.64
.68	.73	2415	.65	.70
.74	.81	2416	.71	.77
.82	.91	2417	.78	.87
.92	.98	2418	.88	.93
.99	1.07	2419	.94	1.02
1.08	1.16	2420	1.03	1.10
1.17	1.27	2421	1.11	1.21
1.28	1.44	2422	1.22	1.37
1.45	1.63	2423	1.38	1.55
1.64	1.88	2424	1.56	1.79
1.89	2.05	2425	1.80	1.95
2.06	2.26	2426	1.96	2.15
2.27	2.55	2427	2.16	2.43
2.56	2.76	2429	2.44	2.63
2.77	3.10	2430	2.64	2.95
3.11	3.35	2431	2.96	3.19
3.36	3.75	2432	3.20	3.55
3.76	4.06	2433	3.56	3.87
4.07	4.64	2434	3.88	4.43
4.65	5.23	2435	4.44	4.99
5.24	5.79	2436	5.00	5.51
5.80	6.20	2437	5.52	5.91
6.21	6.96	2438	5.92	6.71
6.97	7.71	2439	6.72	7.35
7.72	8.15	2441	7.36	7.75
8.16	8.79	2442	7.76	8.47
8.80	9.65	2443	8.48	9.19
9.66	10.6	2444	9.20	10.1
10.7	12.2	2445	10.2	11.6
12.3	13.7	2446	11.7	13.0
13.8	15.7	2447	13.1	14.9
15.8	17.6	2448	15.0	16.8
17.7	19.1	2450	16.9	18.2
19.2	20.9	2451	18.3	19.9
21.0	24.3	2452	20.0	23.1
24.4	26.0	2453	23.2	24.7
26.1	29.3	2454	24.8	27.9
29.4	31.4	2455	28.0	29.9
31.5	34.8	2456	30.0	33.1
34.9	40.1	2457	33.2	38.3
40.2	43.6	2459	38.4	41.5
43.7	45.0	2460	41.6	45.0

**Three Phase Starter Overload Relay Heater
Table - Type TM - Sizes 3 & 4**

Motor Ampere Rating				
Open Starter Bimetallic Relay		Heater Catalog Number	Enclosed Starter Non-Ambient and Open or Enclosed Starters Ambient Compensated Relay	
Min.	Max.		Min.	Max.
7.5	8.2	2514	7.4	7.9
8.3	10.1	2515	8.0	9.9
10.2	10.8	2516	10.0	10.5
10.9	12.1	2517	10.6	11.9
2.2	13.7	2518	12.0	13.5
13.8	17.0	2519	13.6	16.7
17.1	19.2	2520	16.8	18.8
19.3	20.8	2521	18.9	20.3
20.8	23.2	2522	20.4	22.7
23.3	25.2	2523	22.8	24.7
25.3	29.1	2524	24.8	28.5
29.2	32.3	2525	28.6	31.6
32.4	36.0	2526	31.7	35.2
36.1	39.9	2527	35.3	39.1
40.0	43.4	2528	39.2	42.3
43.5	47.6	2529	42.4	46.4
47.7	52.4	2530	46.5	50.8
52.5	59.2	2531	50.9	57.3
59.3	66.0	2532	57.4	63.7
66.1	73.3	2533	63.8	70.7
73.4	80.4	2534	70.8	77.3
80.5	87.9	2535	77.4	83.1
88.0	95.0	2536	83.2	90.9
95.1	102.7	2537	91.0	97.6
102.8	111.9	2538	97.7	106.0
112.0	122.9	2539	106.1	115.4
123.0	133.9	2540	115.5	123.9
134.0	135.0	2541	124.0	135.0

B

TM - NEMA CONTROL

Motor Full Load Current Data

The full load currents listed below are "average values" for motors of several manufacturers. These "average values" are as listed in the National Electrical Code 1996 and must only be used as a guide for selecting suitable branch circuit components.

The rated full load current shown on the motor nameplate is likely to vary from the values listed below .

The NAMEPLATE full load current should always be used in determining the rating of devices.

When using a design "E" Motor Special considerations apply. Refer to NEC 1996 tables 430-151A & B & 430-152, page 70-453/454.

B

FULL-LOAD MOTOR-RUNNING CURRENTS IN AMPERES CORRESPONDING TO VARIOUS A.C. HORSEPOWER RATINGS

Horse Power	115 Volts		230 Volts ^{1,2}		380 Volts		460 Volts		575 Volts		2.3 KV	4.16 KV
	Single Phase	Three Phase	Single Phase	Three Phase	Single Phase	Three Phase	Single Phase	Three Phase	Single Phase	Three Phase	Three Phase	Three H.P.
1/10	--	--	--	--	--	--	--	--	--	--	--	--
1/8	--	--	--	--	--	--	--	--	--	--	--	--
1/6	4.4	--	2.2	--	1.40	--	--	--	--	--	--	--
1/4	5.8	--	2.9	--	1.85	--	--	--	--	--	--	--
1/3	7.2	--	3.6	--	2.32	--	--	--	--	--	--	--
1/2	9.8	4.4	4.9	2.2	3.19	1.28	2.5	1.1	2.0	0.9	--	--
3/4	13.8	6.4	6.9	3.2	4.47	1.78	3.5	1.6	2.8	1.3	--	--
1	16.0	8.4	8.0	4.2	5.12	2.30	4.0	2.1	3.2	1.7	--	--
1.5	20.0	12.0	10.0	6.0	6.38	3.32	5.0	3.0	4.0	2.4	--	--
2	24.0	13.6	12.0	6.8	7.66	4.34	6.0	3.4	4.8	2.7	--	--
3	34.0	--	17.0	9.6	10.87	6.14	8.5	4.8	6.8	3.9	--	--
5	56.0	--	28.0	15.2	17.90	9.71	14.0	7.6	11.2	6.1	--	--
7.5	80.0	--	40.0	22.0	26.80	14.00	21.0	11.0	16.0	9.0	--	--
10	100.0	--	50.0	28.0	33.20	17.90	26.0	14.0	20.0	11.0	--	--
15	--	--	--	42.0	--	26.80	34.0	21.0	27.0	17.0	--	--
20	--	--	--	54.0	--	34.50	44.0	27.0	35.0	22.0	--	--
25	--	--	--	68.0	--	43.50	55.0	34.0	44.0	27.0	--	--
30	--	--	--	80.0	--	51.20	68.0	40.0	54.0	32.0	--	--
40	--	--	--	104.0	--	66.50	88.0	52.0	70.0	41.0	--	--
50	--	--	--	130.0	--	83.10	108.0	65.0	86.0	52.0	--	--
60	--	--	--	154.0	--	103.0	--	77.0	--	62.0	16.	9.
75	--	--	--	192.0	--	128.0	--	96.0	--	77.0	20.	11.
100	--	--	--	248.0	--	165.0	--	124.0	--	99.0	26.	14.3
125	--	--	--	312.0	--	208.0	--	156.0	--	125.0	31.	17.
150	--	--	--	360.0	--	240.0	--	180.0	--	144.0	37.	20.
200	--	--	--	480.0	--	320.0	--	240.0	--	192.0	49.	27.
250	--	--	--	--	--	403.0	--	302.0	--	242.0	60.	33.
300	--	--	--	--	--	482.0	--	361.0	--	289.0	72.	40.
350	--	--	--	--	--	560.0	--	414.0	--	336.0	83.	46.
400	--	--	--	--	--	636.0	--	477.0	--	382.0	95.	52.
500	--	--	--	--	--	786.0	--	590.0	--	472.0	118.	65.

NOTES:

1. To obtain F.L.C. for 200 and 208 Volt motors multiply 230 volts values by 1.15 and 1.10 respectively.
2. To obtain F.L.C. for 265 and 277 Volt motors multiply 230 Volt values by .87 and .83 respectively.

Factory Installed Modifications For Reduced Voltage Starters

Special Enclosure		Cat. Suffix #
Add to NEMA 1 Enclosed Starter for: (Note back & bottom cover plates are required for sizes 5 & 6.)	NEMA 4 Enclosure	61
	NEMA 12 Enclosure	62
Disconnect Devices		
Add to NEMA 1 Enclosed Starter for: Non-Fusible Disconnect Switch Combination	NEMA 1 Enclosure	63
	NEMA 4 Enclosure	64
	NEMA 12 Enclosure	65
Add to NEMA 1 Enclosed Starter for: Fusible Disconnect Switch Combination	100A Clips	66
	NEMA 1 200A Clips	67
	Encl. 400A Clips	68
	600A Clips	69
	100A Clips	70
	NEMA 4 200A Clips	71
	Encl. 400A Clips	72
	600A Clips	73
	100A Clips	74
	NEMA 12 200A Clips	75
	Encl. 400A Clips	77
	600A Clips	78
Add to NEMA 1 Enclosed Starter for : Molded Case Circuit Breaker or MCP Combination	NEMA 1 Enclosure	79
	NEMA 4 Enclosure	80
	NEMA 12 Enclosure	81
Auxiliary Devices		
Control Relay (4 pole max.)	NEMA 1 & 12 Encl.	82
	NEMA 4 Enclosure	83
Pneumatic Timing Relay (3 min. max.)	NEMA 1 & 12 Encl.	84
	NEMA 4 Encl. 1320	85
3 Phase Voltage Monitor Relay (Phase loss, Phase reversal, & Undervoltage)	NEMA 1,4, & 12 Encl.	87
Ammeter & 1-Current Transformer	NEMA 1,4 & 12 Encl.	88
Ammeter, Switch & 3-Current Transformer		89
Voltmeter		90
Voltmeter & Switch		91
Elapsed Time Meter		92
Wattmeter		93
Watt-hour meter		94
Convenience Receptacle Mounted on Side		95
Cylinder Lock on Door		96
Space Heater with N.C. Auxiliary		NEMA 1,4 & 12 Encl.

T 82 A A 4JB—26 -

B

TM - NEMA CONTROL

Field Modifications

Modification Kits

Cover Control

Description		For Bulletin Number	Mounting Location	For Enclosure Type	For NEMA Size	Kit Number	Series A
Push Buttons (Momentary)	Start-Stop	6013 & 7707	Case	1, 4 & 12	00-2	KTM-4	
			Cover		00-2 3 & 4	KTM-3 ² KTM4-38	
	Forward-Reverse-Stop	6030-31	Cover	1, 4 & 12	00-2 3 & 4	KTM-18 ² KTM4-51	KTM5-2
Selector Switches (Maintained) ²	Hand-Off-Auto	6013 & 7707	Cover	1, 4 & 12	00-2 3 & 4	KTM-7 ² KTM4-40	
		6030-31-50	Case	1	00-2	KTM-8	
Pilot Lights (Include Red Lens)	120V 240V 480V 600V	6013-30, 6031-50, 7707	Cover	1, 4 & 12	00-2		KTM5-4 KTM5-5 KTM5-6 KTM5-7
	120V 240V 480V 600V				3 & 4		KTM5-4 KTM5-5 KTM5-6 KTM5-7
Reset Buttons (One Reset Per Kit)		6013-30, 6050 (2 Req)	Cover		00-2	KTM32-7	
External Reset for NEMA Type 1, 4 & 12 Enclosed Standard Starters		6013-30, 6050 (2 Req)					
		6013					
External Reset - For use with Joslyn Clark panel mounted overload kits in NEMA 1, 4 & 12 Enclosures. Dimensions from outside surface of enclosure cover to device mounting surface must fall in the range:							
Starter Size 00, 0 & 1	5 7/8" -- 7 1/8"	All	Cover	1, 4 & 12	00-2	KTM32-8 36	
Starter Size 1P & 2	6" -- 7 1/4"						
Panel Mtd. Overload	5 9/16" -- 6 13/16"						

Notes:

1. Kits may be changed in the field from 3-position to 2-position operation. In addition to HAND-OFF-AUTO, four labels are included, marked: FORWARD-OFF-REVERSE; HIGH-OFF-LOW; TEST-LAG-HEAD; ON-OFF.
2. Not suitable for enclosed starters with transformer.

Enclosure Kits ¹

For Use With Bulletin No. of Open Type Devices	NEMA Size	NEMA Type 1 (General Purpose) Kit Number	NEMA Type 12 Industrial Dust tight Kit Number
6013 & 7707	00-2	ETM012-1 ² ETM012-2	ETM122-1 ² ETM122-2
	3 & 4	ETM014-1	ETM124-1
6030, 6031,	00-2	ETM012-2 ² ETM012-3	ETM122-2 ² -----
	3 & 4	ETM014-2	ETM124-2

Transformer Mounting Plate

Bulletin No. of Open Type Devices	NEMA Size	Use with Enclosure Kit No.	Kit Numbers	Bulletin No. of Open Type Devices	NEMA Size	Use with Enclosure Kit No.	Kit Numbers
6013 & 7707	00-2	ETM012-2	KTM-28	7707-PM	20A	ETM012-3	KTM-80
		ETM014-1	KTM4-54				6030-31 & 6050
	3 & 4	ETM044-1		KTM4-54	6030-31 & 6050	3 & 4	ETM014-2 ETM044-2 ETM124-2
		ETM124-1					

Control Circuit Kits

	Bulletin No.	NEMA Size	Kit Number
Auxiliary contacts for cavity mounting in starter and contactors. One Normally Open, Convertible	All	00-4	KTM-10
		U5	KUM35-10
One Normally Closed, Convertible	All	00-4	KTM-11
		U5	KUM35-11
For side mounting on starters and contactors Two Normally Open, Non-Convertible	All	00-2	KTM-20
		3-4	KTM-19
Transformer Kits: Complete J Fused primary a midget single fused 120V secondary 4			
		VA Capacity	Primary Voltage
Notes: Can be used in NEMA 1, 4 & 12 enclosures that have available space. See enclosure kits to determine those with available space.	All (See Note at Left)	00-2	208
			240 & 480
			600
50/60	All (See Note at Left)	00-2	208
			240 & 480
			600
3 & 4	All (See Note at Left)	3 & 4	208
			240 & 480
			600

Notes:

- For use with the listed open type devices. Each kit includes external "Reset" button(s) and "Reset" plug(s), either of which may be installed in the pre drilled enclosure cover. All enclosures have sufficient space to allow mounting a transformer or other equipment of similar size, unless otherwise noted.
- Does not have space for transformer.
- External "Reset" not included. For external "Reset", add Kit Number KTM32-20.
- Will not fit standard enclosures.
- Not applicable to NEMA 1 - Bulletin 6018, 6038 & 6058

TM - NEMA CONTROL

Field Modification Kits

B

Figure Number	Overall Dimensions - inches			Enclosure Kit Number
	Height	Width	Depth	
1	10 1/8	6 3/4	6 7/16	ETM012-1
	10 1/8	12 5/8	6 15/32	ETM012-2
	14 1/2	12 5/8	6 1/2	ETM012-3
	22	12	9	ETM014-1
	24 3/8	18 1/2	9	ETM014-2
2	11	7 1/4	6 15/32	ETM122-1
	11	13 1/8	6 15/32	ETM122-2
	22 5/8	12 1/4	9 3/16	ETM124-1
	26 3/8	18 3/4	9 3/16	ETM124-2

Enclosure Dimensions

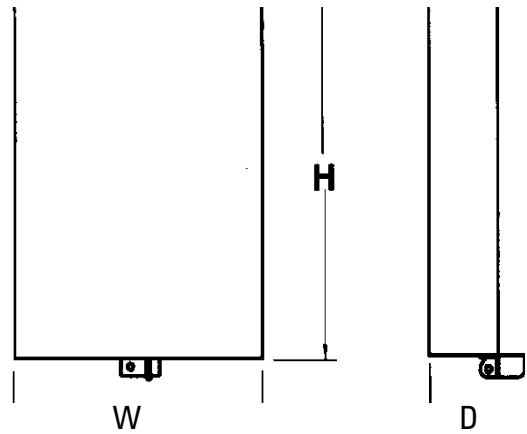

NEMA 12 Enclosure Dimensions Modified for Outdoor Use

Joslyn Clark NEMA 12 enclosures may be field modified for outdoor use as follows:

NEMA 3

1. Watertight conduit hubs shall be used at all conduit entrances.

NEMA 3R

2. Drain holes of 1/8 inch diameter shall be added to the bottom of the enclosure.

Description of Kit	For NEMA Size	Kit Number
Power Contact Kit, For 3 Pole Type TM Starter Or Contactor (Movable And Stationary Contacts & Springs)	00,0,&1 1P,2 3 4	KTM31-1 KTM32-1 KTM33-1 KTM34-1
Power Contact Kit, For Type TM Normally Open Auxillary Side-mounted Power Pole on 1 & 2 Pole Starters And Contactors (1 Kit Required Per Pole-Movable And Stationary Contacts & Springs)	0&1 1P &2 3 4	KTM31-2 KTM32-2 KTM43-1 KTM44-1
Power Contact Kit, For Normally Closed Type TM Auxillary Side-mounted Power Pole (Movable And Stationary Contacts & Springs)	0,1,1P &2 3 4	KTM32-17 KTM43-2 KTM44-2
Replacement Overload Relay, Standard Bimetallic, Less Heaters, For Single Phase Type TM Starter. Non Ambient Compensated	00,0,1&1P	KTM31-14
Replacement Overload Relay, Non Ambient Compensated, Less Heaters, For 2 or 3 Phase	00,0,1 &1P	KTM31-15
	Type TM Starter	KTM32-15
	3	KTM33-15
	4	KTM34-15
	5&611	KTM35-13
Replacement Overload Relay, Ambient Compensated, Less Heaters, For 2 or 3 Phase Type TM Starter	00,0 &1	KTMA31-15
	1P &2	KTMA32-15
	3	KTMA33-15
	4	KTMA34-15
	5 &611	KTMA35-13
Power Contact Kit, 3 Pole Type "U" Size 5 Starter or Contactor (Movable & Stationary Contacts & Springs)	5	KUM35-1
For Replacement Parts For Size 6 Vacuum Contactors, refer to Section A	6	_____

Coil Part Numbers For Volts/Hertz

NEMA Size	Poles	110-120	200-208	220-240	277	380	440-480	550-600
00-2	2-4	TB159-1	TB159-10	TB159-2	TB159-13	TB159-11	TB159-3	TB159-4
3	2-4	TB162-7	TB162-14	TB162-8	TB162-13	TB162-15	TB162-9	TB162-10
4	2-4	TB162-1	TB162-16	TB162-2	TB162-18	TB162-17	TB162-3	TB162-4
5 U Series	2-3	335L1	_____	335L2	_____	_____	335L3	335L4

TM - NEMA CONTROL

Dimensions

NEMA Open Type, Type 1, 4 & 12

Open Type		Dimensions - inches				
NEMA Size	Poles	Wide	High	Deep	Mounting	
		A	B	C	D	E
00	3	3 ⁷ / ₈	4 ¹ / ₄	4 ⁵ / ₈	3 ³ / ₄	1 ¹ / ₂
0-1	1-3	3 ⁷ / ₈	4 ¹ / ₄	4 ⁵ / ₈	3 ³ / ₄	1 ¹ / ₂
0-1	4	4 ⁷ / ₈	4 ¹ / ₄	4 ¹³ / ₁₆	3 ³ / ₄	1 ¹ / ₂
2	2-3	3 ⁷ / ₈	4 ¹ / ₄	4 ¹⁵ / ₁₆	3 ³ / ₄	1 ¹ / ₂
2	4	4 ⁷ / ₈	4 ¹ / ₄	4 ¹⁵ / ₁₆	3 ³ / ₄	1 ¹ / ₂
3-4	2-3	5 ⁷ / ₁₆	8 ¹ / ₈	7 ¹ / ₁₆	6 ⁷ / ₈	3 ¹ / ₂
3-4	4	6 ¹⁵ / ₁₆	8 ¹ / ₈	7 ¹ / ₁₆	6 ⁷ / ₈	3 ¹ / ₂
5	2-3	8 ³ / ₄	12 ¹ / ₄	9 ¹ / ₂	11 ¹ / ₂	7
6		See Section A				
Type 1						
00	3	6 ³ / ₄	9 ¹ / ₂	6 ¹ / ₄	7 ³ / ₄	5
0-2	1-4	6 ³ / ₄	9 ¹ / ₂	6 ¹ / ₄	7 ³ / ₄	5
3-4	2-4	12	22	9	19	9
5	2-3	22	49	11 ³ / ₈	47 ¹ / ₂	18
6		See Section A				
Type 1 (with transformer)						
00	3	12 ⁵ / ₈	9 ¹ / ₂	6 ¹ / ₄	7 ³ / ₄	11
0-2	1-4	12 ⁵ / ₈	10 ¹ / ₈	6 ¹ / ₄	9 ¹ / ₂	11
3-4	2-4	12	22	9	19	9
5	2-3	22	49	11 ³ / ₈	47 ¹ / ₂	18
6		See Section A				
Type 12						
00	3	7 ¹ / ₄	11	6 ¹⁵ / ₁₆	10 ¹ / ₂	4 ¹
0-2	1-4	7 ¹ / ₄	11	6 ¹⁵ / ₁₆	10 ¹ / ₂	4 ¹
3-4	2-4	12 ¹ / ₄	24 ⁵ / ₈	9 ³ / ₁₆	23 ¹ / ₂	7 ¹
5	2-3	22	49	11 ³ / ₈	47 ¹ / ₂	18
6		See Section A				
Type 12 (with transformer)						
00	3	13 ¹ / ₈	11	6 ¹⁵ / ₁₆	10 ¹ / ₂	6
0-2	1-4	13 ¹ / ₈	11	6 ¹⁵ / ₁₆	10 ¹ / ₂	6
3-4	2-4	12 ¹ / ₄	24 ⁵ / ₈	9 ³ / ₁₆	23 ¹ / ₂	7 ¹
5	2-3	22	49	11 ³ / ₈	47 ¹ / ₂	18
6		See Section A				

Notes:

- One top mtg. keyhole on center line.

Magnetic Contactors

Open Type

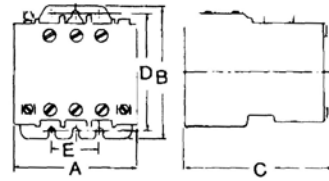

NEMA Type 1

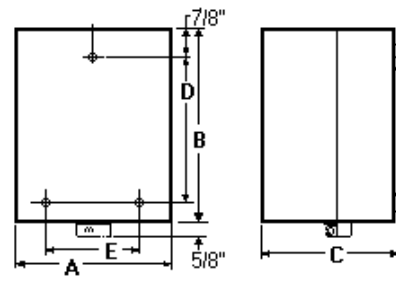

NEMA Type 12

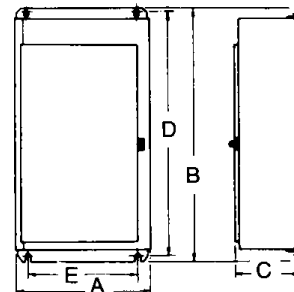

Conduit Hub Size and Location

Encl. Size	Top & Bottom	Bottom Only	H	J	K
00-1	3/4	3/4	3	1 ⁵ / ₈	1 ⁵ / ₈
2	1 ¹ / ₂	3/4	3	1 ⁵ / ₈	1 ⁵ / ₈
3	2	3/4	3	2	2
4	2 ¹ / ₂	3/4	3	2	2
5	3	3/4	5	3	3

B

TM - NEMA CONTROL Dimensions

AC Magnetic Starters

Open Type

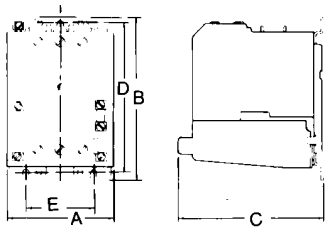

Size 5

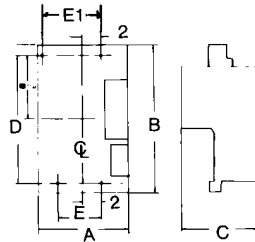

NEMA Type 1 — Sizes 00 to 4

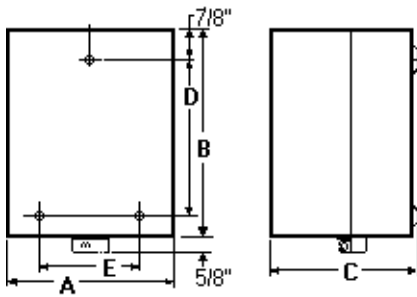

NEMA Type 1 — Size 5

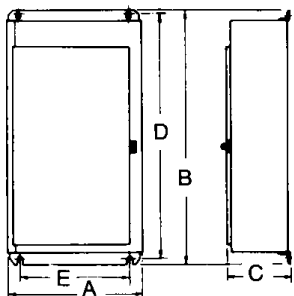

Conduit Hub Size and Location

Encl. Size	Top & Bottom	Bottom Only	H J K		
			H	J	K
00-1	3/4	3/4	3	1 5/8	1 5/8
2	1 1/2	3/4	3	1 5/8	1 5/8
3	2	3/4	3	2	2
4	2 1/2	3/4	3	2	2
5	3	3/4	5	3	3

Notes:

- One top mtg. keyhole on center line.

NEMA Open Type, Type 1, 4 & 12

Open Type		Dimensions - inches				
NEMA Size	Poles	Wide	High	Deep	Mounting	
		A	B	C	D	E
00	2-3	3 7/8	6	5 3/16	5 1/2	2 1/2
0-1	1-3	3 7/8	6	5 3/16	5 1/2	2 1/2
0-1	4	4 7/8	6	5 3/16	5 1/2	2 1/2
1P	2	3 7/8	6	5 3/16	5 1/2	2 1/2
2	2-3	3 7/8	6	5 3/16	5 1/2	2 1/2
2	4	4 7/16	6	5 3/16	5 1/2	2 1/2
3-4	3	5 15/16	11	7 1/16	9 3/4	3 1/2
3-4	4	6 7/8	11	7 1/16	9 3/4	3 1/2
5	3	10 1/8	15 7/8	9 5/8	13 1/2	6 3/8
6		See Section A				
Type 1						
00	2-3	6 3/4	9 1/2	6 1/4	7 3/4	5
0-2	2-4	6 3/4	9 1/2	6 1/4	7 3/4	5
1P	2	6 3/4	9 1/2	6 3/4	7	5
3-4	3-4	12	22	9	19	9
5	3	72	49	11 3/8	47 1/2	18
6		See Section A				
Type 1 (with transformer)						
00	2-3	12 5/8	9 1/2	6 1/4	7 3/4	11
0-2	2-4	12 5/8	10 1/8	6 1/4	9 1/2	11
1P	2	12 5/8	10 1/8	6 1/4	9 1/2	11
3-4	3-4	12	22	9	19	9
5	3	22	49	11 3/8	47 1/2	18
6		See Section A				
Type 12						
00	2-3	7 1/4	11	6 15/16	10 1/2	4 1
0-2	2-4	7 1/4	11	6 15/16	10 1/2	4 1
1P	2	7 1/4	11	6 15/16	10 1/2	4 1
3-4	3-4	12 1/4	24 5/8	9 3/16	23 1/2	7
5	3	22	49	11 3/8	47 1/2	18
6		See Section A				
Type 12 (with transformer)						
00	2-3	13 1/8	11	6 15/16	10 1/2	6
0-2	2-4	13 1/8	11	6 15/16	10 1/2	6
1P	2	13 1/8	11	6 15/16	10 1/2	6 1
3-4	3-4	12 1/4	24 5/8	9 3/16	23 1/2	7
5	3	22	49	11 3/8	47 1/2	18
6		See Section A				

TM - NEMA CONTROL

Dimensions

NEMA Open Type, Type 1 & 12

Open Type Starter			Dimensions - inches					
NEMA Size	Poles	Fig.	Wide	High	Deep	Mounting		
			A	B	C	D	E	E1
00	3		8 ³ / ₁₆	6	5 ³ / ₁₆	5 ¹ / ₂	6 ¹³ / ₁₆	4 ⁵ / ₁₆
0-1	3		8 ³ / ₁₆	6	5 ³ / ₁₆	5 ¹ / ₂	6 ¹³ / ₁₆	4 ⁵ / ₁₆
0-1	4		9 ⁹ / ₁₆	6	5 ³ / ₁₆	5 ¹ / ₂	6 ¹³ / ₁₆	4 ⁵ / ₁₆
2	3		8 ³ / ₁₆	6	5 ³ / ₁₆	5 ¹ / ₂	6 ¹³ / ₁₆	4 ⁵ / ₁₆
2	4	1	9 ³ / ₁₆	6	5 ³ / ₁₆	5 ¹ / ₂	6 ¹³ / ₁₆	4 ⁵ / ₁₆
3-4	3		11 ⁵ / ₁₆	8 ¹ / ₈	7 ¹ / ₁₆	6 ⁷ / ₈	9 ³ / ₈	5 ⁷ / ₈
3-4	4		14 ¹⁵ / ₁₆	8 ¹ / ₈	7 ¹ / ₁₆	6 ⁷ / ₈	9 ³ / ₈	5 ⁷ / ₈
5	3		Starter Refer Factory					
6			See Section B					
Type 1 Contactors and Starters								
00	3	5	12 ⁵ / ₈	9 ¹ / ₂	6 ¹ / ₄	7 ³ / ₄	11	*
0-2	3-4	5	12 ⁵ / ₈	9 ¹ / ₂	6 ¹ / ₄	7 ³ / ₄	11	*
3-4	3-4	5	18 ¹ / ₂	25 ³ / ₄	9	23	16	16
5	3	6	22	49	9 ³ / ₈	47 ¹ / ₂	18	
6			See Section B					
Type 1 (with transformer) Contactors and Starters								
00	3	5	12 ⁵ / ₈	13 ³ / ₈	6 ¹ / ₄	12 ³ / ₄	11	*
0-2	3-4	5	12 ⁵ / ₈	13 ³ / ₈	6 ¹ / ₄	12 ³ / ₄	11	*
3-4	3-4	5	18 ¹ / ₂	25 ³ / ₄	9	23 ¹ / ₂	16	16
5	3	6	22	49	9 ³ / ₈	47 ¹ / ₂	18	
6			See Section B					
Type 12 Contactors and Starters								
00	3		13 ¹ / ₈	11	6 ¹⁵ / ₁₆	10 ¹ / ₂	6	6
0-2	3-4		13 ¹ / ₈	11	6 ¹⁵ / ₁₆	10 ¹ / ₂	6	6
3-4	3-4	7	18 ³ / ₄	23 ³ / ₈	9 ³ / ₁₆	27 ¹ / ₂	13	13
5	3		22	49	11 ³ / ₈	47 ¹ / ₂	18	
6			See Section B					
Type 12 (with transformer) Contactors and Starters								
00	3	8	17	13	6 ⁷ / ₈	9	6	6
0-2	3-4	8	17	13	6 ⁷ / ₈	9	6	6
3-4	3-4	7	18 ³ / ₄	28 ³ / ₄	9 ³ / ₁₆	27 ¹ / ₄	13	13
5	3	7	22	49	11 ³ / ₈	47 ¹ / ₂	18	
6			See Section B					

Notes:

- One top mtg. keyhole on center line.

Reversing Starters

Open Type

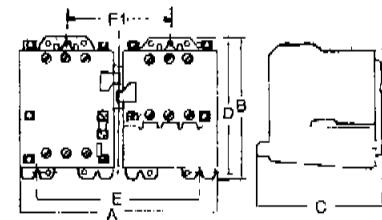
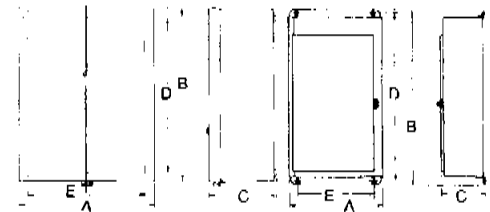

Fig. 1



NEMA Type 1

Fig. 2

NEMA Type 4

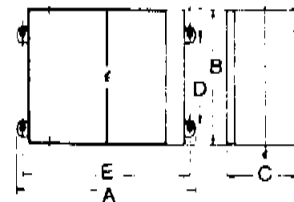

Fig. 4

Steel Enclosure

NEMA Type 12 — No Hub Provisions

Conduit Hub Size and Location

Enclo. Size	Top & Bottom	Bottom Only	Location		
			H	J	K
00-1	3/4	3/4	3	1 ⁵ / ₈	1 ⁵ / ₈
2	1 ¹ / ₂	3/4	3	1 ⁵ / ₈	1 ⁵ / ₈
3	2	3/4	3	2	2
4	2 ¹ / ₂	3/4	3	2	2
5	3	3/4	5	3	3

Open Type

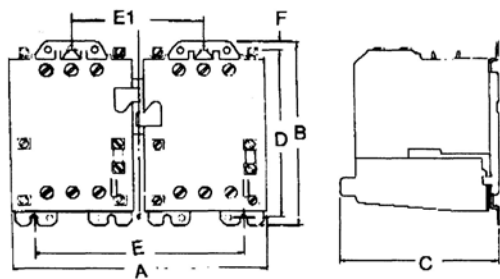

Fig. 1

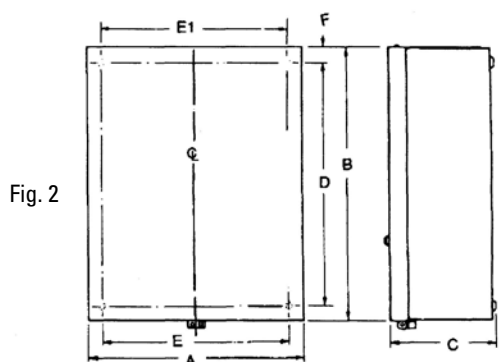
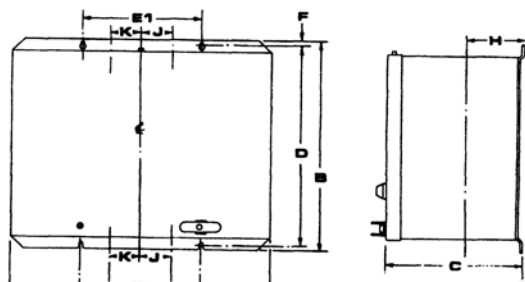
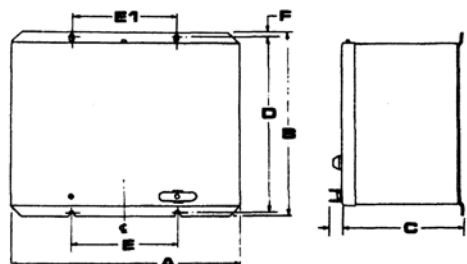

Fig. 2



NEMA Type 4



NEMA Type 12-No Hub Provisions

AC Non-Reversing 2 Speed Starters

NEMA Size	Open Type Fig.	Dimensions - inches			Mounting			
		Wide A	High B	Deep C	D	E1	E	F
Open type - 2 Speed, Single Winding								
00-2	1	9 ³ / ₁₆	6	5 ⁵ / ₁₆	5 1/2	1 1/2	4 ⁵ / ₁₆	1/4
3-4		13 ³ / ₁₆	11	7 ¹ / ₁₆	9 ³ / ₄	5 ⁷ / ₈	9 ³ / ₈	5/16
Type 1 - 2 Speed, Single Winding								
00-2	2	12 ⁵ / ₈	9 1/2	6 ³ / ₄	7 ³ / ₄	4 ⁵ / ₁₆	6 ¹³ / ₁₆	1/4
3-4		18 1/2	25 ³ / ₄	9	23	5 ⁷ / ₈	9 ³ / ₈	5/16
Type 1 - 2 Speed, Single Winding (with transformer)								
00-2	2	12 ⁵ / ₈	13 ⁷ / ₈	6 1/4	12 ³ / ₄	1	11	7/8
3-4		18 1/2	25 ³ / ₄	9	23	16	16	1 ³ / ₈
Type 12 - 2 Speed, Single Winding								
00-2	4	13 ¹ / ₈	11	6 ¹⁵ / ₁₆	10 1/2	6	6	1/4
3-4		18 ³ / ₄	28 ³ / ₈	9 ⁹ / ₁₆	27 1/4	13	13	9/16
Type 12 - 2 Speed, Single Winding (with transformer)								
00-2	4	15	13	6 ⁷ / ₈	10 1/2	16	16	1/4
3-4		18 ³ / ₄	28 ³ / ₈	9 ⁹ / ₁₆	27 1/4	13	13	9/16

B

TM - NEMA CONTROL

Engineering Data

Ratings - Controllers - Type TM

Continuous ampere and maximum horsepower ratings are in accordance with the following NEMA Standards:
Starters ICS 2-32 1B, ICS 2-321F ; Contactors ICS 2-211.23, ICS 2-211.24

Power Wiring Accommodation - Type TM1

NEMA Size 2	Wire Range			Wire Type	Pressure Terminal Type	Provision For Ring Tongue Lugs 3	
	Line	Load				Terminal Width, In.	Screw Size
		Contactor	Overload				
00	#14-#6	#14-#6	#14-#4	Copper (Cu)	Saddle	.625	#10-32
0	#14-#6	#14-#6	#14-#4	Copper (Cu)	Saddle	.625	#10-32
1	#14-#6	#14-#6	#14-#4	Copper (Cu)	Saddle	.625	#10-32
2	#14-#4	#14-#4	#14-#4	Copper (Cu)	Box	.62	#10-32
3	#8-#2/0	#8-#2/0	#8-#2/0	Copper (Cu)	Box	1.04	⁵ / ₁₆ -18
4	#6-250MCM	#6-250MCM	#6-250MCM	Copper (Cu)	Box	1.04	³ / ₄ -18
5	#4-500MCM	#4-500MCM	#4-500MCM	Aluminum	Box	1.25	³ / ₈ -Hole
6	(2)#4-500MCM	(2)#4-500MCM	(2)#4-500MCM	or Copper (Cu)		1.25	³ / ₈ -Hole

1 For aluminum (Al) load wiring accommodations on Size 00-4, refer to local sales office.

2 Devices are equipped with one (1) lug p/er phase, except size 6.

3 UL specifies only one (1) wire per lug.

Control Circuit Contact & Coil Terminals - Type TM

NEMA Size	Terminal Type	Copper Wire Size 4,5 Min. - Max.	Screw Size
00-6	Pressure Saddle	#18-#12AWG	#8-32

4 One or two stranded copper wires of same size, or differing by (2) gauge sizes.

5 Coil terminal wire on TM 00-2 is #14 AWG maximum.

Control Circuit Contact Rating - Type TM

10 Ampere Continuous Rating - Maximum 600 Volts, AC or DC

NEMA Size	Contacts	Volts, AC	Amperes Continuous	A-C Inductive (0.35pf)		Volts, DC	D-C Inductive Make or Break
				Make	Break		
00-4	KTM-10 KTM-11	120V or less 120-600V	10	30A 3600VA	3A 360VA	125V 250V (300V OR LESS) 600V	1.1 .55A (138VA) .2A
00-2 3-4	KTM-20 KTM-19						

Overload Relay Contact Ratings - Type TM

NEMA Size	Contact	Volts, AC	Continuous Amperes	A-C Inductive (0.35pf)	
				Make	Break
00-6	N.C.	120V or less	2.5	15A	1.5A
		120-600V		1800VA	180VA
	N.O	120V or less		3A	.3A
		120-600V		360VA	36VA

Control Transformer Sizes For Type TM A-C Contactors Or Starters

NEMA		60Hz.		50Hz.		25Hz.	
		Volt - Amperes		Volt - Amperes		Volt - Amperes	
Size	Poles	Inrush	Sealed	Inrush	Sealed	Inrush	Sealed
00-2	2-4	210	18	210	20	135	19
3	2-4	724	30	724	32	--	--
4	2-4	880	39	880	42	--	--
5	2-3	1790	295	--	--	--	--
6 ¹	2-3	3160	435	3300	490	--	--

1. Size 6 has two operating coils connected in series. Values given for two coils so connected.

Coil Burden - Type TM

Contactor or Starter		Transformer Sizes- Volt-Amperes, 60 Hertz	
NEMA Size	No. of Poles	Standard Capacity	100W Extra Capacity
00.0. 1 & 2	2-4	50	150
3 & 4	2-4	250	500
5	2-3	350	500
6 ²	2-3	50	150

2. For starter with control relay; starter coil is full voltage.

Ratings Of Low-Voltage Contactors For Transformer Primaries 3

Contactor Size	Transformer Rating 4 -KVA, 50/60 Hz.					8-Hour Rating of Contactor Amperes	
	Single Phase			Three Phase			
	115V	230V	460 or 575V	230V	575V	Open	Enclosed
0	0.9	1.4	1.9	1.7	2.5	20	18
1	1.4	1.9	3	4.1	5.3	30	27
2	1.9	4.6	5.7	7.6	12	50	45
3	4.6	8.6	14	15	23	100	90
4	5.7	11	22	23	46	150	135
5	14	28	40	46	91	300	270
6	28	57	86	91	180	600	540

3. This table does not apply to transformers in resistance welding service.
 4. This table applies to contactors used with transformers having an inrush of not more than (20) times their full-load current, irrespective of the nature of the secondary load.

Kilowatt Ratings Of Low-Voltage Transformers

For Resistive-Heating Loads Other Than Infrared-Lamp Loads 5 Per NEMA ICS 2.210-1

Contactor Size	1 Φ 2-Pole Contactors (Open or Closed) Heating Load, KW				3 Φ 3-Pole Contactors (Open or Closed) Heating Load, KW			8-Hour Rating of Contactor Amperes	
	115V	230V	460V	575V	230V	460V	575V	Open	Enclosed
1	3	6	12	15	10	20	25	30	27
2	5	10	20	25	17	34	43	50	45
3	10	20	40	50	34	68	86	100	90
4	15	30	60	75	52	105	130	150	135
5	30	60	120	150	105	210	260	300	270
6	60	120	240	300	210	415	515	600	540
7	90	180	360	450	315	625	775	900	810

5. This Table applies to contactors used to switch the load at the utilization voltage of the heat-producing elements with a duty which requires continuous operation of not more than five (5) openings per minute.

B

TM - NEMA CONTROL

Engineering Data

For Starters 6013-TM;
Contactors 7707-TM Non-Combination

Wiring Diagram Front View

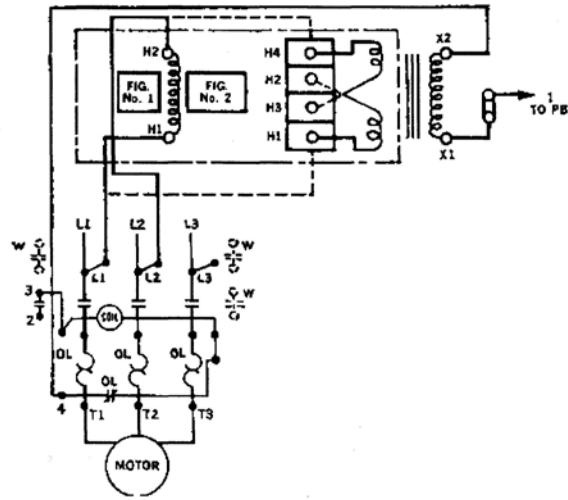
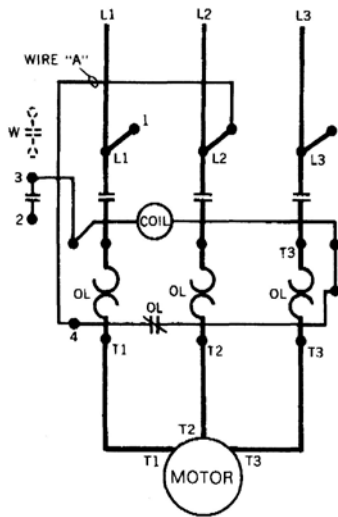

Connection For Pilot Devices

Cover Mounted Pilot Devices		3 Wire Control Remote Pilot Devices	Transformer Connections				
	<p>Connect To Coil Terminals</p>		Volts	Connections	L1	L2	Fig.
			240	H1 & H3, H2 & H4	H1	H4	2
			480	H2 & H3	H1	H4	2
			All	--			
			Others				
Start-Stop Pushbutton	Pilot Light	Momentary Contact Pushbutton	Automatic Reset Automatic reset operation should not be used with two wire control.				
<p>3 Position Selector Switch (Remove Lead From Coil to Term No. 3)</p> <p>Two Wire Contact Device</p> <p>To L H Coil Term</p>		<p>2 Position Selector Switch (Remove Lead From Coil To Term No. 3)</p> <p>To L H Coil Term</p>	Separate Control Remove wire "A" when it is supplied. Connect separate control lines to the "1" terminal on the pilot device and the "4" terminal on the starter. Coil Terminal wire to be #14 AWG maximum.				

B

For Starters 6030-TM; Contactors 6031-TM

Elementary Diagram

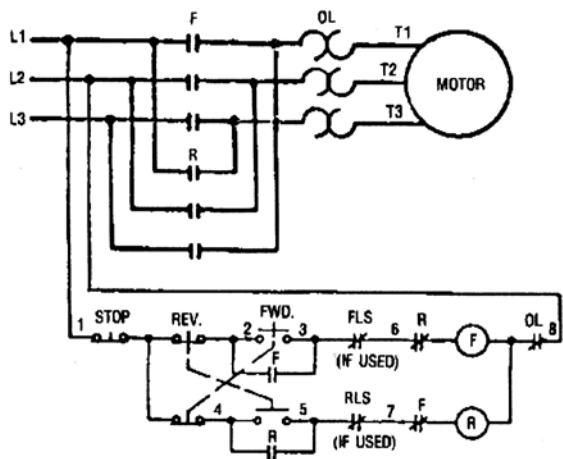

Separate Control

Remove wire "A" when it is supplied. Connect separate control lines to the "1" terminal on the pilot device and the "8" terminal on the starter. Coil terminal wire to be No. 14 AWG maximum.

Push button Control

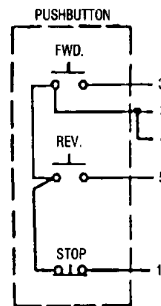

Wiring Diagram Front View

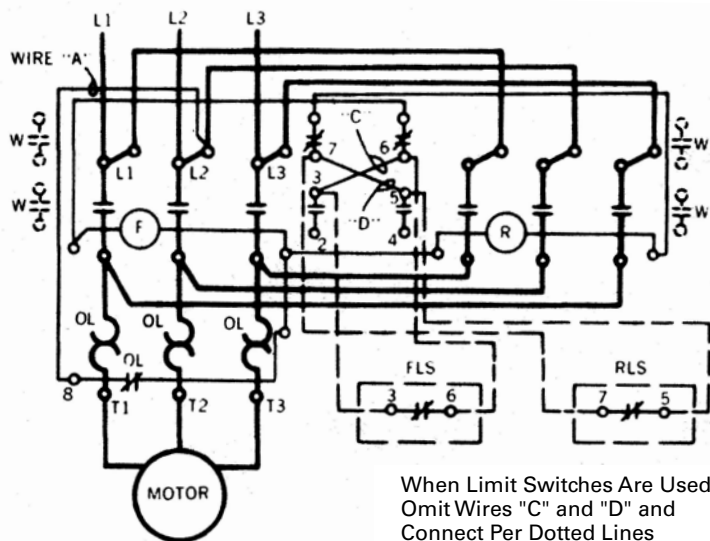

When Limit Switches Are Used
Omit Wires "C" and "D" and
Connect Per Dotted Lines

Contactors "F" & "R" Are
Mechanically Interlocked

B

TM - NEMA CONTROL

Engineering Data

For Starters 6050-TM

Elementary Diagram

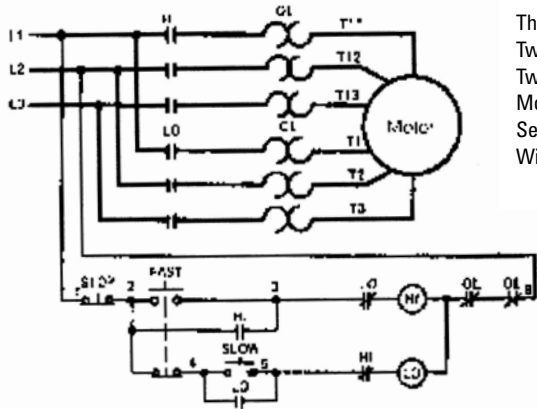

Three Phase
Two Speed
Two Winding
Motor
Separate
Winding

Separate Control

Remove wire "A" when it is supplied
Connect separate control lines to the
"1" terminal on the pilot device and
the "8" terminal on the starter. Coil
terminal wire to be No. 14 AWG
maximum.

Pushbutton Control

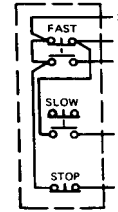

Wiring Diagram Front View

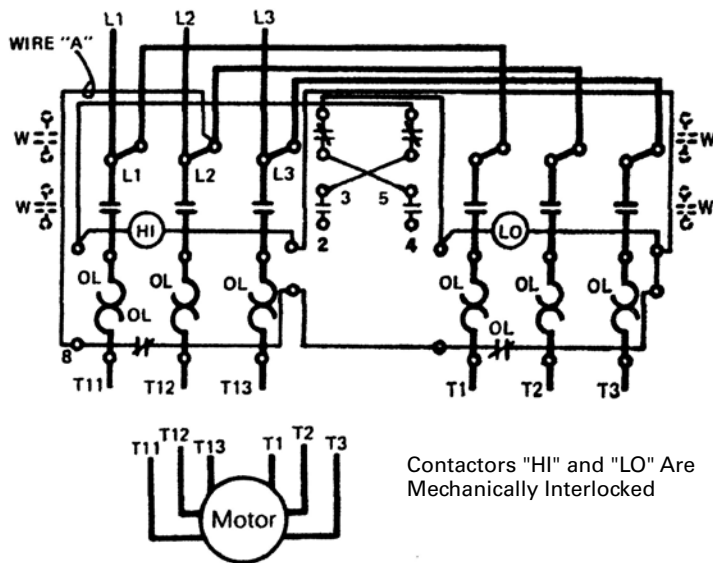

Contactors "HI" and "LO" Are
Mechanically Interlocked

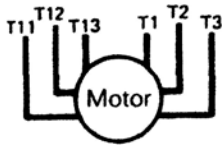

B

For Starters 6050-TM

Elementary Diagram

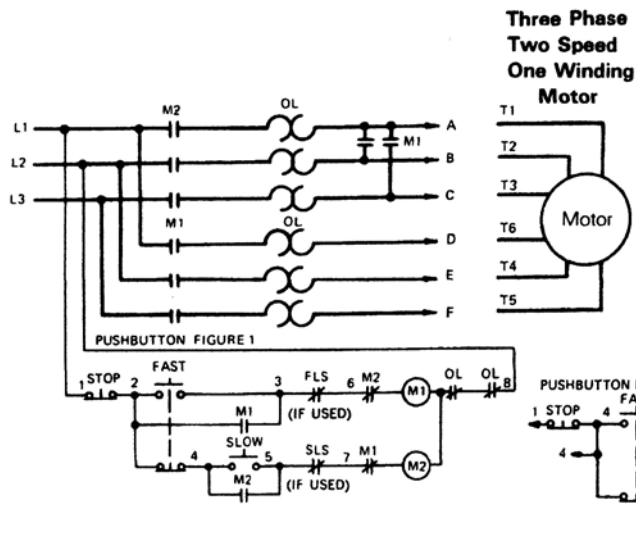

Wiring Diagram Front View

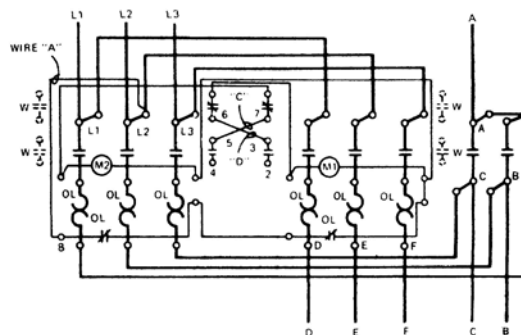

Momentary Contact Pushbuttons

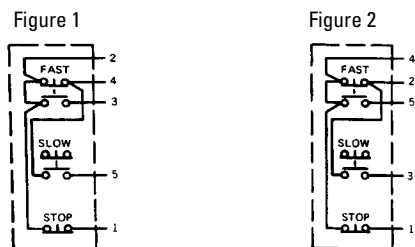

Connections Of Motor And Push-button Terminals To Starter Terminals

Motor	Push-button	A	B	C	D	E	F	M1	M2
Figure 1	Figure 2	T6	T4	T5	T1	T2	T3	Low	High
Figure 2	Figure 1	T1	T2	T3	T6	T4	T5	High	Low
Figure 3	Figure 1	T1	T2	T3	T6	T4	T5	High	Low

Three Phase Two Speed One Winding Motor Connection Data

Figure 1 Constant Horsepower						Figure 2 Constant Torque					Figure 3 Variable Torque						
L1	L2	L3	Open	Together	Speed	L1	L2	L3	Open	Together	Speed	L1	L2	L3	Open	Together	Speed
T1	T2	T3	_____	T4,T5,T6	Low	T1	T2	T3	T4,T5,T6	_____	Low	T1	T2	T3	T4,T5,T6	_____	Low
T6	T4	T5	T1,T2,T3	_____	High	T6	T4	T5	_____	T1,T2,T3	High	T6	T4	T5	_____	T1,T2,T3	High

B

TM - NEMA CONTROL Numbering System

Contactors & Non Combination Starters

B

Type of Starter or Contactor	
T	Standard unit with standard TM size 00-4 starter or contactor.
V	Standard unit with standard Vacuum starter or contactor.
U	Standard unit with standard TM size 5 starter or contactor.
A	Standard unit except with ambient compensated overload relays.
K	Irrigation Pump Controller.

Product Code	
13	- Starters
30	- Rev. Starter
31	- Rev. Contactors
77	- Contactors
90	- Part Winding Starters

Enclosure Type	
A	- NEMA 1
W	- NEMA 4
T	- NEMA 12
U	- Open Type

Cover Control	
A-	Reset button in cover for overloads.
B-	Reset button and Hand-Off-Auto selector switch.
C-	Reset button and Start-Stop push button
O-	None (no reset button or controls in cover)

T 13 A A 3 1 - 46

Number of Poles	
1	- One Pole
2	- Two Pole
3	- Three Pole
4	- Four Pole

NEMA Size or Amp. Rating	
A	- Size 00
O	- Size 0
1	- Size 1, 1PW
P	- Size 1 1/2
2	- Size 2, 2PW
3	- Size 3, 3PW
4	- Size 4, 4PW
5	- Size 5, 5PW
6	- Size 6, 6PW

Suffix With Transformer		Suffix W/O Transformer	
(secondary 110-120V with single fuse)		Coil Volts & Hertz	Suffix
Transformer Primary Volts & Hertz	Suffix	110-120/60 or 110/50	- 76
	Standard Capacity	220-240/60 or 220/50	- 26
220-240/60 or 220/50	100 Watt Extra Capacity	440-480/60 or 440/50	- 46
		550-600/60 or 550/50	- 56
208/60	- T26	208/60	- 86
440-480/60 or 440/50	- T46		
550-600/60 or 550/50	- T56		
208/60	- T86		
380/50	- T35		
220/25	- T22		
440/25	- T42		
	- C26		
	- C46		
	- C56		
	- C86		
	- C35		
	- C22		
	- C42		

Reduced Voltage Auto Transformer Starters

B

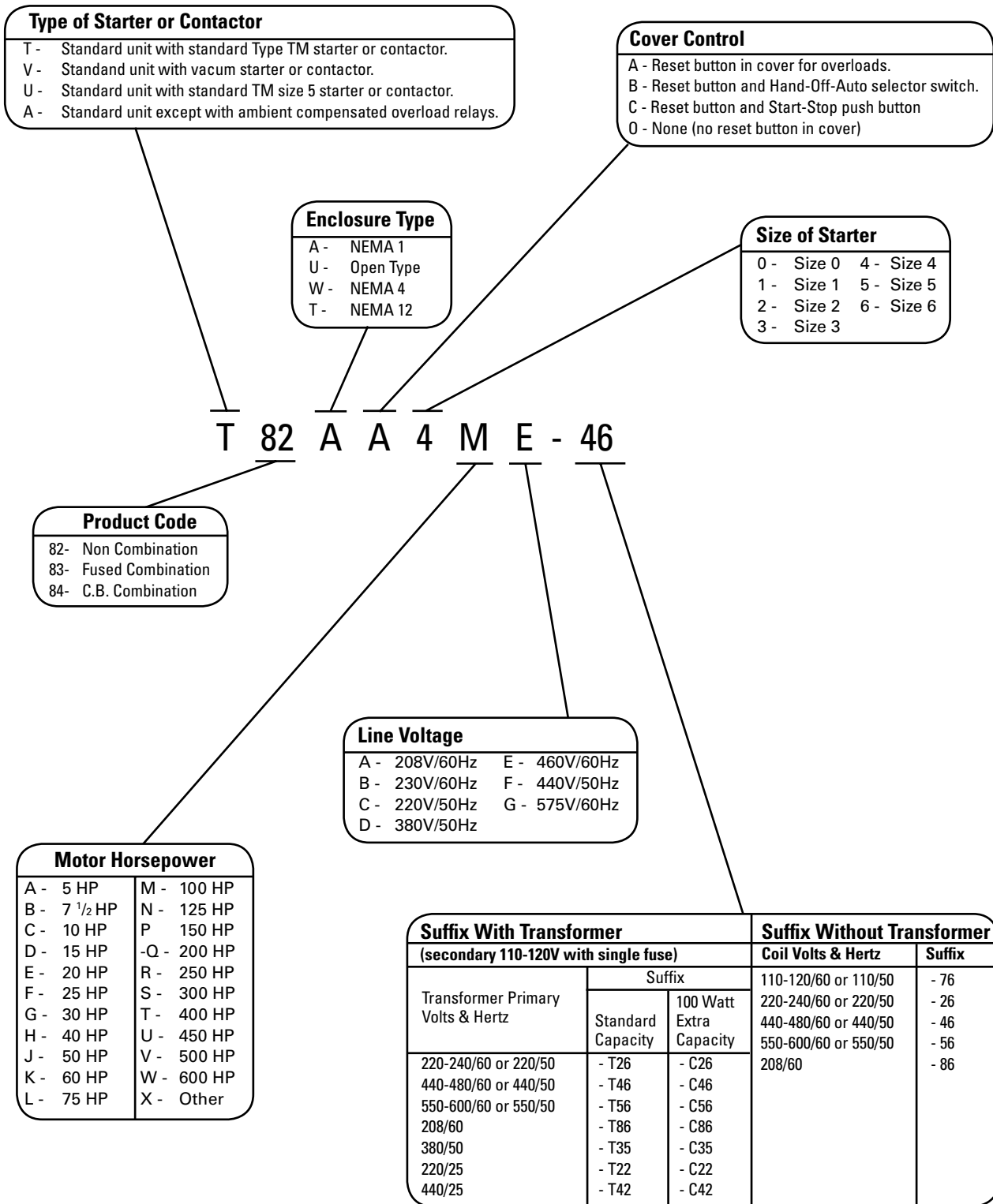

AC CONTROL - 5000

General Information

Application

The 5000 Space Savers in NEMA Sizes 00 thru 5 offer versatile and compact AC contactors for industrial motor, heating and other power circuit switching. Simplified design coupled with built-in reliability assures the user long, trouble-free operation in machine tools, process controls, air-conditioning, custom panels and other demanding applications.

Description

All 5000 magnetically operated contactors incorporate a modern, modular design compatible with other control component modules. Terminal location make them ideal for straight-through wiring and for wire-channel layouts. Accessible, up-front pressure-type terminals are standard. The hot molded, high arc resistant two or three piece housings not only totally enclose contacts and operating coils for environmental protection; but also separate them as added protection against internal phase-to-phase short circuits. Generous size, long wearing double break contacts are furnished on all sizes. Contacts are made of silver cadmium oxide for "anti-weld" protection under high inrushes. Contacts do not require adjustment or periodic dressing (filing).

Coil Data

Standard coils for continuous duty service are equipped with pressure type terminals. Molded coil construction resists moisture; thermal and mechanical stress.

Typical User Benefits:

- Modern Modular Design - makes contactors compatible with other control panel components. Ideal for wire-channel layouts.
- Compact Size - 5000 Contactors conserve control panel area without sacrificing accessibility or reliability. The 100 amp. Size 3 contactors occupy less than 19.0 sq. in. of panel space.
- Only 15 Basic Parts - This simple design affords longer operating life and greater reliability than more complex units.
- Fast Installation - Accessible up-front pressure type terminals on both power and control circuits, take unplugged stripped wire. Design permits straight-through wiring.
- Quick, Easy Inspection - Simply withdraw the front housing piece, after removing two screws, all main contacts are in full view. No need to disturb wiring or remove contactor from panel for complete inspection of all parts.

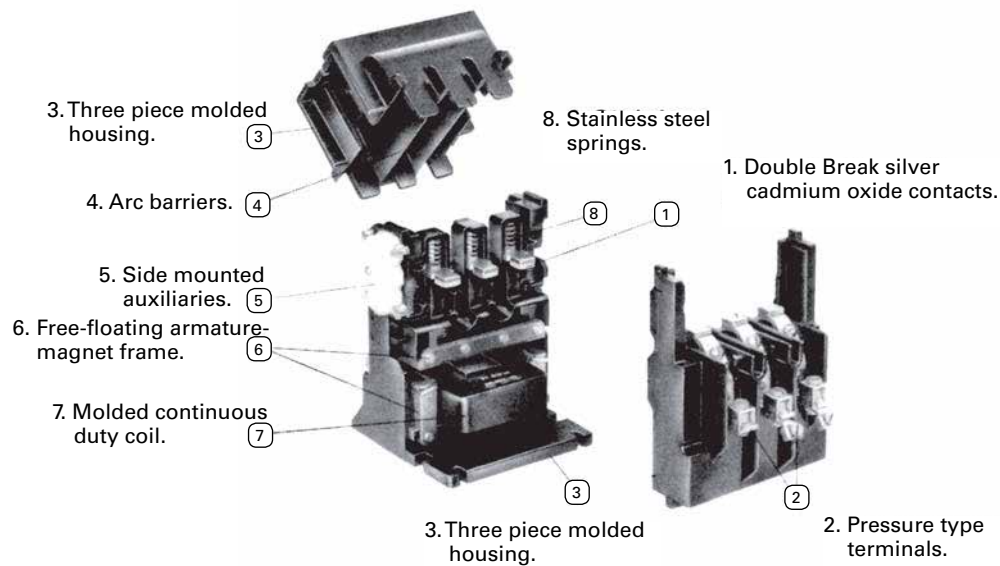

AC CONTROL - 5000

Non-Reversing Contactors

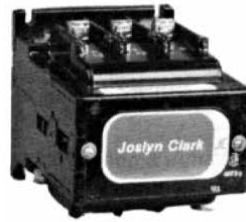

B

3 Pole Contactors - Three Phase

NEMA Size	8-Hour Rating in Amperes		Open Type Catalog No.
	Open	Enclosed	
00	10	9	5009A3001-
0	20	18	5000A3001-
1	30	27	5001A3001-
2	50	45	5002A3001-
3	100	90	5003A3001-
4	150	135	5004-3001-
5	300	270	5005-3001-

Auxiliary Contact Rating

AC Volts	Sizes 00 - 5	
	Amperes	
	Continuous	Inrush
120	6	60
280	3	30
480	1.5	15
600	1.2	12

Auxiliary Contacts (Interlocks)

NEMA Size	Max. No. of N.O. or N.C. or N.O. - N.C. Auxiliary units
00, 0 & 1	2
2, 3, 4, 5	4

Ratings¹ - Ampere and Horsepower, Single Speed Motors

NEMA Size	Amperes		Three Phase - Horsepower Rating						Single Phase - Horsepower Rating			
			Starting			Plug-Stop or Jogging Duty			Starting		Plug-Stop or Jogging Duty	
	Open	Enclosed	115V	230V	480/575V	115V	230V	480/575V	115V	230V	115V	230V
00	10	9	3/4	1 1/2	2	----	----	----	1/3	1 1/2	----	----
0	20	18	2	3	5	1	1 1/2	2	1	2	1/2	1
1	30	27	3	7 1/2	10	2	3	5	2	3	1	2
2	50	45	7	15	25	----	10	15	3	7	2	5
3	100	90	----	30	50	----	20	30	----	----	----	----
4	150	135	----	50	100	----	30	60	----	----	----	----
5	300	270	----	100	200	----	75	150	----	----	----	----

Notes:

1. These ratings are based on locked rotor current not exceeding six times motor full load current for the max. horsepower rating.

Ordering Information

- Use complete catalog number. Replace the (*) with the suffix from the coil table.
- Modification Page

* Coil Table

NEMA Size	DC Voltage	Suffix	NEMA Size	60Hz/Voltage	Suffix
00-5 incl.	24	82	00-5 incl.	120	11
00-5 incl.	48	32	3,4,5	208/240	21
00-5 incl.	120	12	00,0,1,2	208	90
00-5 incl.	240	22	00,0,1,2	240	21
			00-5 incl.	480	41
			00-5 incl.	600	51

AC CONTROL - 5000

Modifications & Accessories

Accessory Kits & Special Features

For Field Installation Auxiliary Interlocks For NEMA Sizes 00-5 Contactors		Kit No.
N.O. Std.		5M63
N.C. Std.		5M64
N.O. & N.C. Std.		5M65
N.O. Low Power		5M63L
N.C. Low Power		5M64L
N.O. & N.C. Low Power		5M65L
N.O. Std. & N.C. Low Power		5M66
N.O. Low Power & N.C. Std.		5M65L0
N.C. Std. Early Close		5M64E ²
N.O. Low Power & N.C. Std. Late Break		5M68E
N.C. Low Power - Late Break		5M64LE
N.O. Std. & N.C. Low Power Late Break		5M67 ²
N.O. Low Power & N.C. Low Power		5M69 ²
Tandem Mounting Kit ¹		5M60DA
Reversing & Multi-Speed Accessory Kit	Starter or Contactor Size	Kit No.
Mechanical Interlock	00, 0 & 1 ³	5M115
	0 & 1 ⁴	5M110
	2, 3, & 4	5999-4737
	2 ³	5999-4717
	5	5999-4757
Reversing Contactor Base Plate: Series 5000	5to4	5999-4748
	0 & 1	23081.692-1
	2 & 3A	23082.79
	4	23083.30
	5	23085.312-1

Notes:

1. Contains mounting hardware only. Order auxiliary separately.
Not for 7000 or 7001 Series Contactors.
2. Not for use on 5000 contactor size 00, 0, 1 & 2 or 5DP contactors 10/40, 40 & 75 amp. sizes.
3. For use with style A contactors only. Style A contactors are identified by the letter A following the fourth digit in the catalog number.
4. Not for use on style A contactors.
5. Kit contains: stationary contacts, movable contacts & contact springs.

Contact Kits - 1 Pole⁵

Basic Cat. No.	NEMA Size	Discount Sch. JC80
5009A or B	00	5M87
5000A or B	0	5M87
5000-	0	5M50
5001A or B	1	5M19
5001-	1	5M51
5002A or B	2	5999-2521
5002-	2	5M52
5003A or B	3	5M80
5003-	3	5M53
5004-	4	5M54
5005-	5	5999-0045

AC Coil Data and Coil Kits

Basic Cat. No.	NEMA Size	Volts 60Hz	V.A. 60Hz		Kit No.	
			Inrush	Sealed		
5009A	00	120	120	28	5ML25	
5000A	0	208			5ML26	
5001A	1	240			5ML29	
		480			5ML27	
		600			5ML28	
5002A	2	120	290	48	5999-1801	
		208			5999-1805	
		240			5999-1802	
		480			5999-1803	
		600			5999-1804	
5002	2	120	264	41	5ML21	
		240			5ML22	
5003A	3	480			5ML23	
		600			5ML24	
5003	3	120	672	72	5ML41	
		240			5ML42	
5004	4	480			5ML43	
		600			5ML44	
5005	5	120	1776	144	5ML51	
		240			5ML52	
		480			5ML53	
		600			5ML54	

OPEN TYPE CONTACTORS — DIMENSIONS — Approx.
 Contactor base must be mounted vertically.

SIZE 00, 0 & 1 — 3-pole

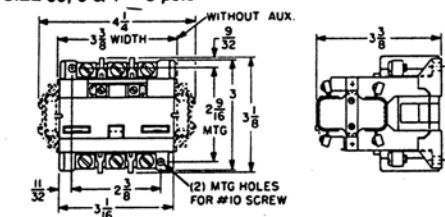

SIZE 2 — 3-pole

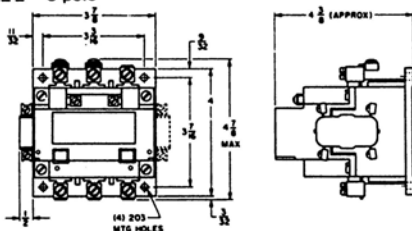

SIZE 3 — 3-pole

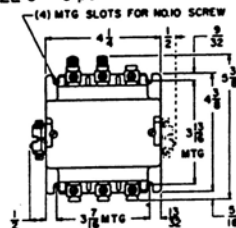

SIZE 4 — 3-pole

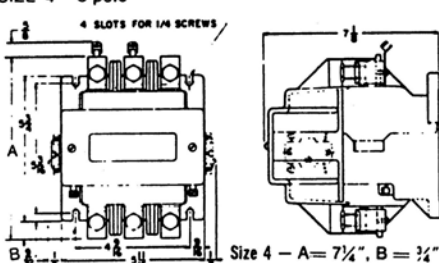

SIZE 5 — 3-pole

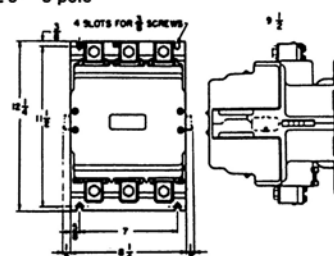

SIZE 6 & 7

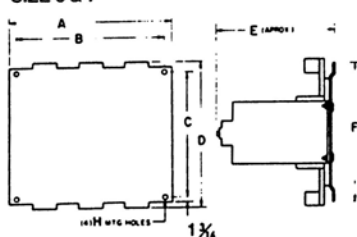

SIZES 6 and 7 — 2 and 3-pole

NEMA SIZE	No. of Poles	DIMENSIONS — In Inches — Approx						
		A	B	C	D	E	F	H
6	2	11 1/4	10 3/4	12 1/4	14 3/4	11 1/2	13 1/4	1 1/2
6	3	16 1/4	14 3/4	12 1/4	14 3/4	11 1/2	13 1/4	1 1/2
7	2 or 3	21 1/4	19 1/4	17 1/4	19 1/4	14 1/4	19 1/4	3/4

DIMENSIONS — Approximate
 Reversing Contactor base plate must be vertically mounted with long dimension horizontal.

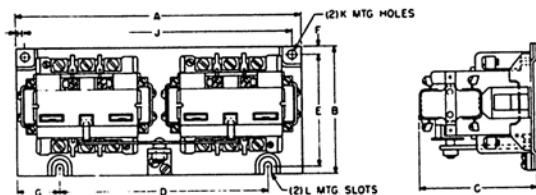

Fig. 1 Sizes 0 and 1 — Open type

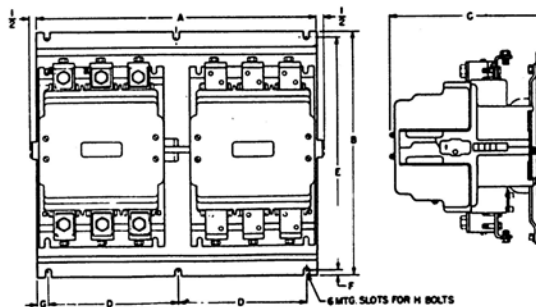

Fig. 3 Size 5 — Open type

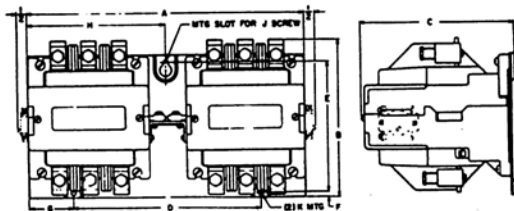

Fig. 2 Sizes 2, 3 and 4 — Open type

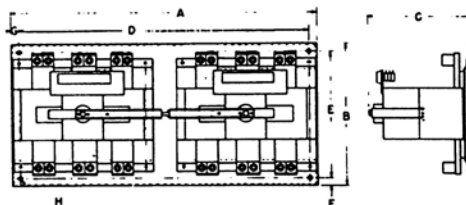

Fig. 4 Size 6 — Open type

OPEN TYPE REVERSING CONTACTORS

Series 5200

NEMA Size	Dim. Fig.	DIMENSIONS — In Inches										
		A	B	C	D	E	F	G	H	J	K	L
0 & 1	1	8 3/4	3 1/4	3 3/4	6 1/4	3 3/4	1/4	1 3/4	1/2	8 1/4	.281	.266
2	2	10 3/4	5 1/4	4 1/2	7 1/4	4 3/4	1/4	1 1/2	5 1/2	1/4	.281	—
3	2	10 3/4	5 1/4	6 1/8	7 1/8	4 3/4	1/4	1 11/32	5 5/32	1/4	.281	—
4	2	13 3/4	7 1/2	7 3/4	9	6 3/4	1/4	2 3/2	6 1/2	1/4	1/4	—
5	3	18 3/4	16 1/2	10 3/4	8 1/2	15 1/2	3/8	2 1/2	3/4	—	—	—
6	4	35 1/4	16 1/2	12 1/4	33 3/4	14 3/4	1/4	3/8	3/4	—	—	—

NEMA CONTROL

Contactors & Starters Index



Description	Page Number
General Information - HP	C2 - C3
AC Magnetic Contactors - HP	C4
AC Magnetic Reversing Contactors - HP	C4
AC Magnetic Starters - HP	C5
AC Magnetic Reversing Starters - HP	C5
AC Magnetic Combination Starters - HP	C6
Modifications and Parts.....	C7
Engineering Data.....	C8 - C11
For HP Overload Heaters see SectionB Index.....	B14

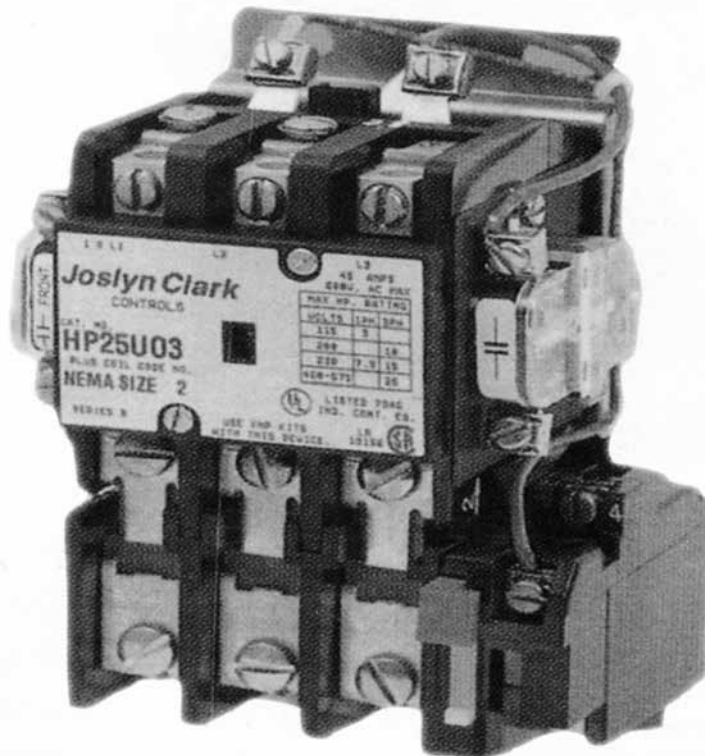

NEMA CONTROL - HP

General Information

**The Joslyn Clark NEMA Size Starter
That Saves You Money**



NEMA Type 1 Enclosed
Non - Reversing Starter

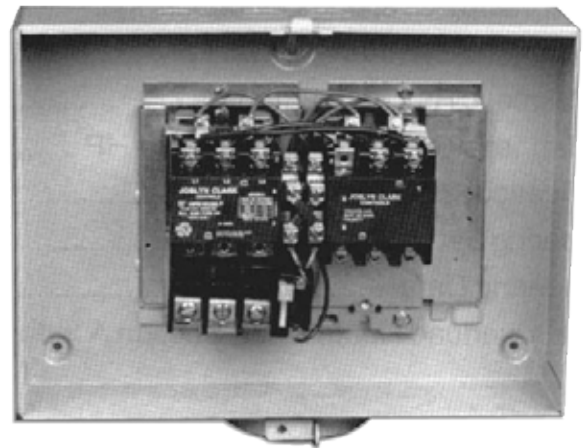

NEMA Type 1 Enclosed
Reversing Starter

C

Quality — with economy of cost and space

The Joslyn Clark HP Motor Starter has been developed through many generations of controllers. Closely related to the TM design, the HP starter is rated for its horsepower capability as well as in standard NEMA frame sizes. Like the TM starter, our HP starter was designed in one piece as a starter, a single integrated unit consisting of a power contactor and a thermal overload relay mounted on a rigid common base.

This compact starter takes less than 19 sq. in. of panel space, permitting the use of smaller, less costly enclosures. It provides more wiring space for easy wiring and requires only two mounting screws to save installation time and cost.

NEMA sizes 00, 0, 1 & 2 are the same small physical size, providing greater flexibility.

NEMA Sizes 00, 0, 1, & 2 Quality — with economy of cost and space

LOW ENERGY 8.4 VA COIL

Same energy efficient coil for NEMA sizes 00, 0, 1 & 2. Reduces transformer size and cost. Small transformer size saves panel space. Low VA inrush coil reduces line disturbance, ideal for use with solid state control.

TRUE "UP-FRONT" "STRAIGHT THROUGH" WIRING DESIGN

Makes the HP Starter easy to wire and safe to trace. Save through reduced wiring time and panel cost.

SMALL SIZE

Requires only 19 sq. in. of panel space.

COVER NAME PLATE

Clear and easy to identify size, rating, and catalog number.

AUXILIARY CONTACTS

- Easy to install
- Clear side cover
- One Kit may be attached to each side of the starter providing up to four contacts
- Contacts positive driven from main contact carrier
- Contact Kits -
 - One N.O. KHP - M10
 - Two N.O. KHP - M20
 - N.O. & N.C. KHP - M11

"UNIQUE" SPRING LOAD TERMINALS

For fast load connection. Save by reducing starter wiring time.

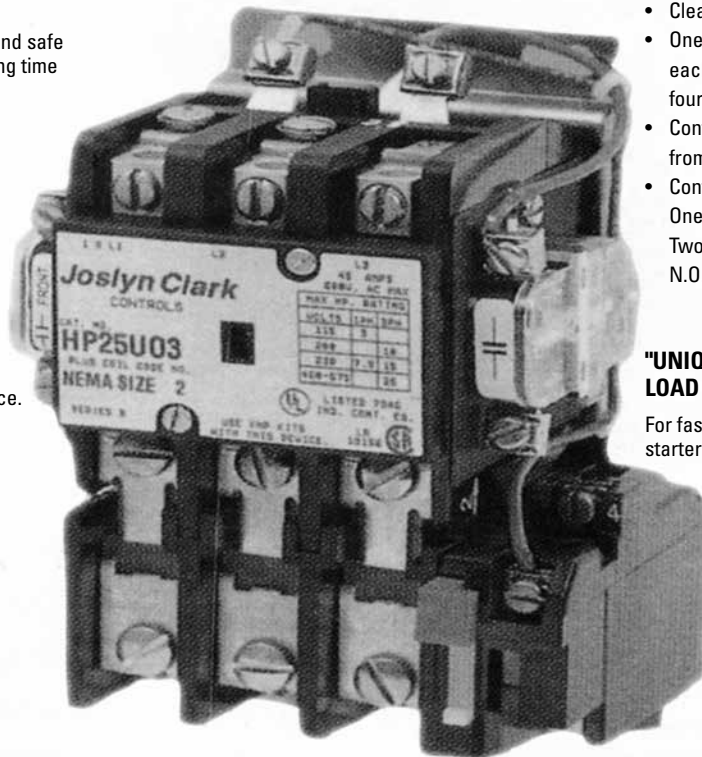

NEMA CONTROL - HP

AC Contactors

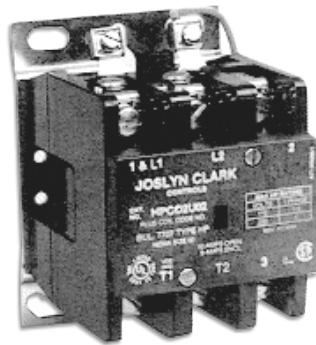

HPC020U2



HPC10AA3

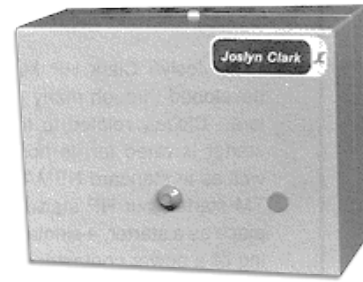

HPRC25A03

Non-Reversing Contactors - Type HPC

2-Pole, Single Phase								
NEMA Size	Maximum Motor Horsepower Rating			Continuous Ampere Rating	Tungs Lamp Load	NEMA Type 1 General Purpose Catalog No. ¹	NEMA Type 12 Industrial - Dust-tight Catalog No. ¹	Open Type Catalog No. ¹
	115V	220V	460V					
00	1/3	1	2	9	5	HPC02A02 *	HPC02T02 *	HPC02U02 *
0	1	2	5	18	10	HPC05A02 *	HPC05T02 *	HPC05U02 *
1	2	3	10	27	15	HPC10A02 *	HPC10T02 *	HPC10U02 *
2	3	7 1/2	25	45	30	HPC25A02 *	HPC25T02 *	HPC25U02 *

3-Pole, Three Phase								
NEMA Size	Maximum Motor Horsepower Rating			Continuous Ampere Rating	Tungs Lamp Load	NEMA Type 1 General Purpose Catalog No. ²	NEMA Type 12 Industrial - Dust-tight Catalog No. ²	Open Type Catalog No. ²
	200V	230V	460/575V					
00	1 1/2	1 1/2	2	9	5	HPC02A03 *	HPC02T03 *	HPC02U03 *
0	3	3	5	18	10	HPC05A03 *	HPC05T03 *	HPC05U03 *
1	7 1/2	7 1/2	10	27	15	HPC10A03 *	HPC10T03 *	HPC10U03 *
2	10	15	25	45	30	HPC25A03 *	HPC25T03 *	HPC25U03 *

Reversing Contactors - Type HPRC

3-Pole, Three Phase							
NEMA Size	Maximum Motor Horsepower Rating			Continuous Ampere Rating	NEMA Type 1 General Purpose Catalog No. ²	NEMA Type 12 Industrial - Dust-tight Catalog No. ²	Open Type Catalog No. ²
	200V	230V	460/575V				
00	1 1/2	1 1/2	2	9	HPRC02A03 *	HPRC02T03 *	HPRC02U03 *
0	3	3	5	18	HPRC05A03 *	HPRC05T03 *	HPRC05U03 *
1	7 1/2	7 1/2	10	27	HPRC10A03 *	HPRC10T03 *	HPRC10U03 *
2	10	10	25	45	HPRC25A03 *	HPRC25T03 *	HPRC25U03 *

Note:

1. Includes contactor complete with one N.O. control-circuit contact.
2. Includes contactor complete with N.O. interlock on each contactor. All contactors are mechanically and electrically interlocked.

Ordering Information	Coil Table			
	60Hz Voltage	Suffix	60Hz Voltage	Suffix
<ul style="list-style-type: none"> • Use complete catalog number when ordering. Replace the (*) with the suffix from the coil table. • Engineering Data page C10-13. • Modification pages C7-8 	24 Separate Control	-96	200-240	-26
	120 Separate Control	-76	277	-66
			440-480	-46
			550-600	-56

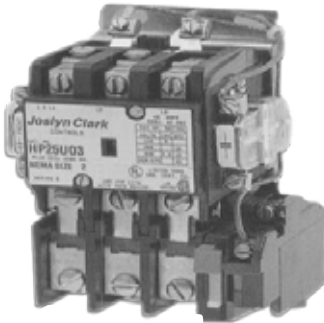

HP10U03

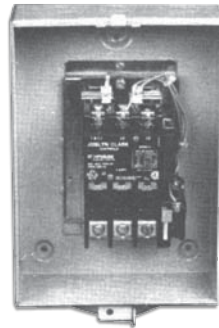

HP02AA3

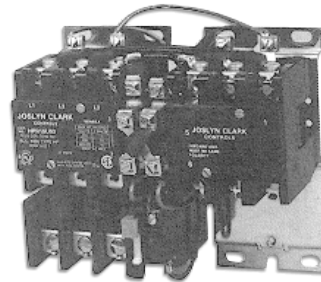

HPR10U03

C

Non-Reversing Starters - Type HP

2-Pole, Single Phase (Requires 1 Overload Heater)							
NEMA Size	Maximum Motor Horsepower Rating			Continuous Ampere Rating	NEMA Type 1 General Purpose	NEMA Type 12 Industrial - Dust-tight	Open Type
	115V	220V	460/575V		Catalog No. ¹	Catalog No. ¹	Catalog No. ¹
00	1/3	1	----	9	HP02AA2 *	HP02TA2 *	HP02U02 *
0	1	2	----	18	HP05AA2 *	HP05TA2 *	HP05U02 *
1	2	3	----	27	HP10AA2 *	HP10TA2 *	HP10U02 *
3-Pole, Three Phase (Requires 3 Overload Heaters)							
NEMA Size	Maximum Motor Horsepower Rating			Continuous Ampere Rating	NEMA Type 1 General Purpose Catalog No. ²	NEMA Type 12 Industrial - Dust-tight Catalog No. ²	Open Type Catalog No. ²
	200V	230V	460-575V				
00	1 1/2	1 1/2	2	9	HP02AA3 *	HP02TA3 *	HP02U03 *
0	3	3	5	18	HP05AA3 *	HP05TA3 *	HP05U03 *
1	7 1/2	7 1/2	10	27	HP10AA3 *	HP10TA3 *	HP10U03 *
2	10	15	25	45	HP25AA3 *	HP25TA3 *	HP25U03 *

Reversing Starters - Type HPR

3-Pole, Three Phase (Requires 3 Overload Heaters)							
NEMA Size	Maximum Motor Horsepower Rating			Continuous Ampere Rating	NEMA Type 1 General Purpose	NEMA Type 12 Industrial - Dust-tight	Open Type
	200V	230V	460/575V		Catalog No. ²	Catalog No. ²	Catalog No. ²
00	1 1/2	1 1/2	2	9	HPR02AA3 *	HPR02TA3 *	HPR02U03 *
0	3	3	5	18	HPR05AA3 *	HPR05TA3 *	HPR05U03 *
1	7 1/2	7 1/2	10	27	HPR10AA3 *	HPR10TA3 *	HPR10U03 *
2	10	15	25	45	HPR25AA3 *	HPR25TA3 *	HPR25U03 *

Note:

1. Includes starter complete with N.O. interlock and overload relay less heaters.
2. Includes starter complete with N.O. interlock on each contactor and overload relay less heaters. All starters are mechanically and electrically interlocked.
3. NEMA 3R add 60.00 to NEMA 12 List

Ordering Information		Coil Table			
<ul style="list-style-type: none"> • Use complete catalog number when ordering. Replace the (*) with the suffix from the coil table. • Engineering Data page C10-13. • Modification pates C7-8 • Spare Parts C8 	60Hz Voltage	Suffix	60Hz Voltage	Suffix	
	24 Separate Control	-96	200-240	-26	
	120 Separate Control	-76	277	-66	
			440-480	-46	
			550-600	-56	

NEMA CONTROL - HP

Modifications & Parts

Modifications

Description	Factory Installation Addition - Change Catalog No. as outlined on Page C9.				For Field Installation Kit Catalog Number Kits Only For Type 1 Enclosures
	For Bulletin Number	Type HP Size	Enclosure Type		
			1	12	
Cover Controls					
Over Load Reset					
Hole plug for Internal Reset (10 per pack)	6013, 6030				KTM-26
Reset Button (one reset per kit)	6013 & 6030				KHP-EC2 A60-306413
Push Buttons & Selector Switches					
Start-Stop Push Buttons	6013,	00,0,1 & 2			KHP-4
Hand-Off Auto Selector Switch	6030,				KHP-8
Forward-Reverse-Stop Selector Switch	6031,				KHP-8
Forward-Reverse-Stop Push Button	& 7707				KTM-18
Pilot Lights					
Without Electrical Interlocks, 120V	6013,				KTM5-4
Standard Transformer Type, 240V	6030,				KTM5-5
with Red Lens. 480V	6031,				KTM5-6
600V	& 7707				KTM5-7
Control Circuit					
Auxillary Contacts					
Extra N.O. Contact	All	All			KHP-M10
Extra N.O. and N.C. Contacts					KHP-M11
Two extra N.O. Contacts					KHP-M20
Enclosure Kits	6013 & 6030				Same as type TM, see Section B

Notes:

1. Kits may be changed in the field from 3-position to 2-position operation. In addition to HAND-OFF-AUTO, four labels are included, marked FORWARD-OFF-REVERSE: HIGH-OFF-LOW, TEST-LAG-LEAD, ON-OFF.
2. Lower Mounting Base for Fuse Clips- required only when converting a non-fusible unit to a fusible unit.

Modifications

Description				For Bulletin Number	Type HP Size	For Field Installation Kit Catalog Number
Control Transformer - Includes Single Fused 120 Volt Secondary						
	VA Capacity	Primary Voltage	Hertz			
Standard ³ Capacity	50	208 240 & 480 600	50 / 60	6013 & 6018	00-2	KTR67-16 KTR67-2 KTR67-12
Extra ³ Capacity	150	208 240 & 480 600				KTR67-20 KTR67-5 KTR67-25
Miscellaneous						
Ambient Compensated Overload Relay				All	00-2	
Fused Control Circuit: Fuse Holder for one fuse Fuse Holder for two fuses				All	00-2	KHP-F1 KHP-F2
Enclosure Adaptor Kits: Starter Mounting Plate Mtg. Plate with O/L Reset - Required with Enclosure Kit Transformer Mtg. Plate ¹						KHP-EC1 KHP-EC3 KTM-28

C

Renewal Parts	Size	Discount Schedule JC80
Replacement Overload	00-2	KHP31-15
Ambient Compensated	00-2	KHPA31-15
Replacement Power Contact Kit for 3 Pole	00-1	KHP31-1
	2	KHP32-1
	Forward Side	KHPR31-S
	00-1 Reverser	KHPR31-C
	Reverse Side	KHPR31-C
	00-1 Reverser	KHPR32-S
	Forward Side	KHPR32-S
	Size 2 Reverser	KHPR32-C
Reverse Side	KHPR32-C	
Size 2 Reverser	KHPR32-C	
Replacement Coil Kits		Discount Schedule JC80
Voltage	Hertz	
110-120	50 or 60	00, 0, 1 & 2
208-240	50 or 60	KTB174-1
440-480	50 or 60	KTB174-2
550-600	50 or 60	KTB174-5
380	50 or 60	KTB174-6
277	50 or 60	KTB174-7
24	50 or 60	KTB174-4
		KTB174-3

Notes:

1. Reversing Starters require 1-KHP-EC1 and 1-KHP-EC3 with reset.
2. Include larger cabinets required for Bul. 6013 & 6030.
3. Includes one secondary fuse and 2 Primary Fuse Clips.

NEMA CONTROL - HP

Engineering Data

Type HP NEMA Sizes 00, 0, 1 & 2 Outline Drawings

C

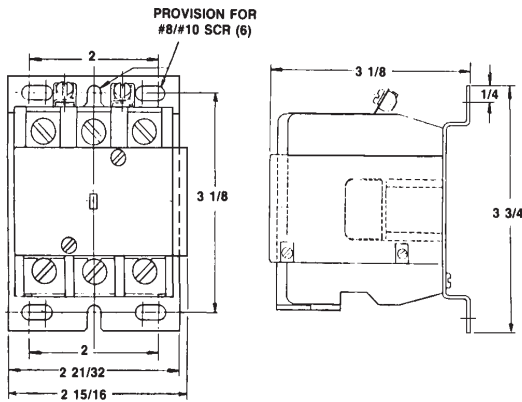

Contactor Type HPC

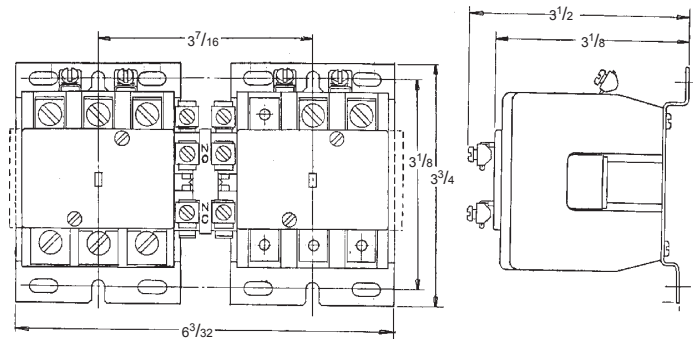

Reversing Contactor Type HPRC

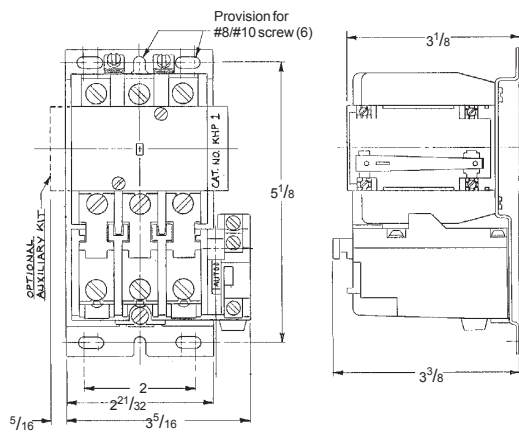

Starter Type HP

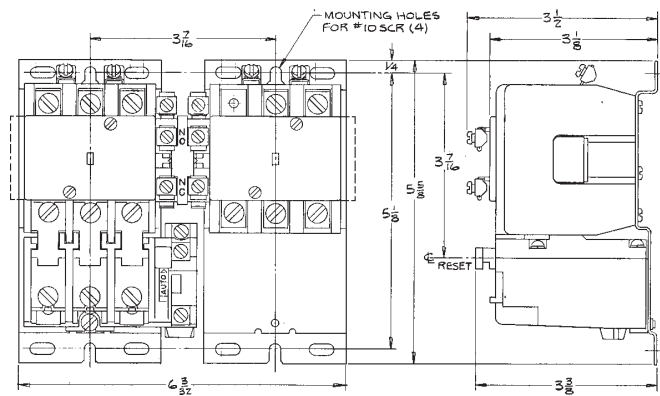

Reversing Starters Type HPR

Power Wiring Accommodations						Control Circuit							
Wire Range		Wire Type	Pressure Terminal Type	Provision for Ring Tongue Lugs ¹		Continuous Amperes	A-C Inductive		Terminal Type	Copper Wire Size Max. ^{2,3}	Screw Size	Coil Burden	
Line	Load			Terminal Width in.	Screw Size		Make	Break				Inrush	Sealed
# 14 - #8	#14 - #4	Copper (Cu)	Pressure Clamp	.450	#10 - 32	5	880VA	40VA	Pressure Saddle	#12AWG	#6 - 32	48VA	8.4VA

Notes:

1. UL specifies only one (1) wire per lug.
2. One or two stranded copper wires of same size, or differing by two (2) gauge sizes.
3. Coil terminal wire size is #14 AWG maximum.

Approximate Dimensions In Inches
Type HP NEMA Sizes 00, 0, 1 & 2 Outline Drawings

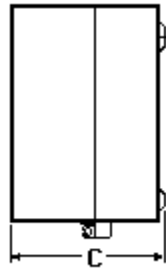
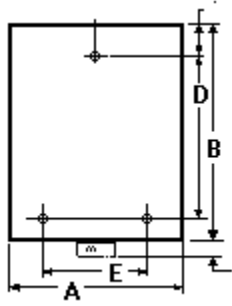

NEMA Type 1 Enclosure

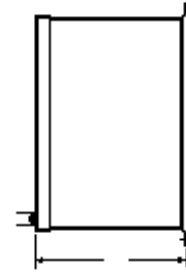
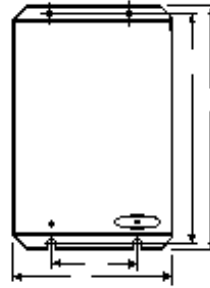

NEMA Type 12 Enclosures

C

Starter Type	NEMA Type 1 Enclosure										NEMA Type 4 & 12 Enclosure									
	Without Transformer					With Transformer					Without Transformer					With Transformer				
	A	B	C	D	E	A	B	C	D	E	A	B	C	D	E	A	B	C	D	E
HP & HPC	6 ³ / ₄	9 ¹ / ₂	6 ¹ / ₄	7 ³ / ₄	5	12 ⁵ / ₈	9 ¹ / ₂	6 ¹ / ₄	7 ³ / ₄	11	7 ¹ / ₄	11	6 ⁷ / ₈	10 ¹ / ₂	4	13 ¹ / ₈	11	6 ⁷ / ₈	10 ¹ / ₂	6
HPR & HPRC	12 ⁵ / ₈	9 ¹ / ₂	6 ¹ / ₄	7 ³ / ₄	11	12 ⁵ / ₈	13 ⁷ / ₈	6 ¹ / ₄	12 ³ / ₄	11	13 ¹ / ₈	11	6 ⁷ / ₈	10 ¹ / ₂	6	17	13	6 ⁷ / ₈	9	16

NEMA CONTROL - HP

Engineering Data

Wiring Diagram Type HP - Non-Combination Starter

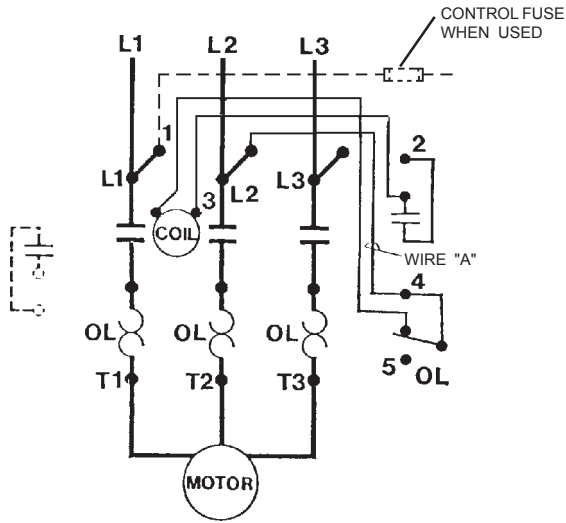

3 Pole, Three Phase

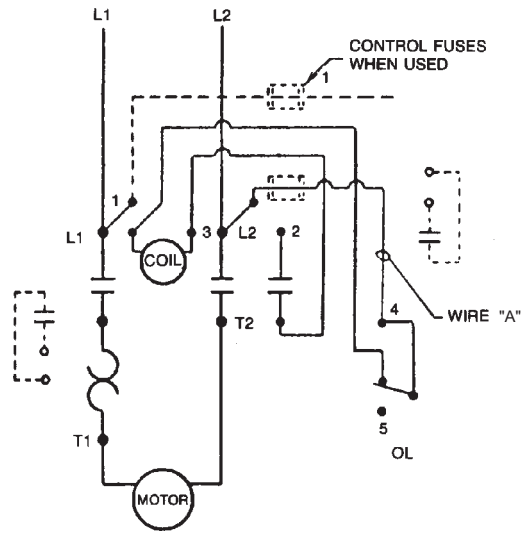

2 Pole, Single Phase

Connection For Pilot Devices

Cover Mounted Pilot Devices		3 Wire Control Remote Pilot Devices		Automatic Reset Automatic reset operation should not be used with two wire control.
<p>Start-Stop Pushbutton</p>	<p>Connect To Coil Terminals Pilot Light</p>	<p>Momentary Contact Pushbutton</p>	<p>Separate Control Remove wire "A" when it is supplied. Connect separate control lines to the "1" terminal on the pilot device and the "4" terminal on the starter.</p>	
<p>3 Position Selector Switch (Remove Lead from Coil to Term No. 3)</p>	<p>2 Position Selector Switch (Remove Lead from Coil to Term No. 3)</p>	<p>Two or More Momentary Contact Pushbutton Stations</p>		

Wiring Diagram
Type HPR - Non-Combination Starters

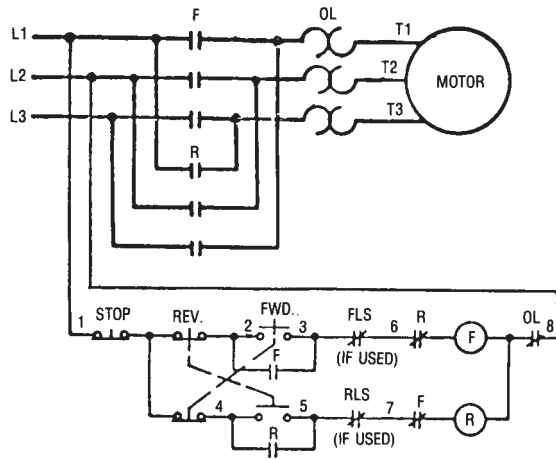

Elementary Diagram

Contactors "F" & "R" are Mechanically Interlocked

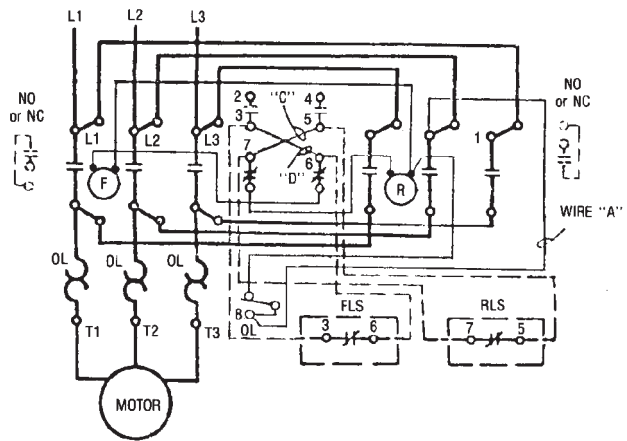

Wiring Diagram Front View

When Limit Switches are used, remove Jumpers "C" & "D" and connect per dotted lines.

Two Wire Control for Maintained Pushbuttons	Three Wire Control for Momentary Control Pushbuttons	
		<p>Automatic Reset Automatic reset operation should not be used with two wire control.</p> <p>Separate Control Remove wire "A" when it is supplied. Connect separate control lines to the "1" terminal on the pilot device and the "8" terminal on the starter.</p>
<p>Pushbutton with Forward and Reverse Buttons Electrically Interlocked</p>		

100T Push Button



Description	Page Number
100T Push Buttons:	
General Information.....	D2
Push Buttons - Std. & Mushrooms	D4
Key Operated - Push Pull Push Buttons.....	D5
Illuminated Push Buttons.....	D6
Illuminated Push Pull Units.....	D7
Pilot Lights & Press-to-Test Pilot Lights.....	D8
Selector Switches: 2 - 3 - 4 Position	D9
Assembled Push Button Units	D10
Assembled Stations: 1 - 2 - 3 Elements	D11
Assembled Selector Switch Units	D12
Separate Enclosures: 1 - 5 Hole	D13
Legend Plates	D14
Accessories	D15
Dimensions & Ratings	D16
Catalog Numbering System	D17 - D18

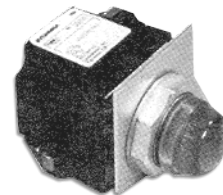
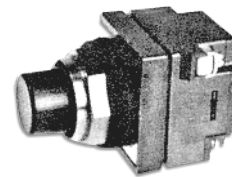

D



Joslyn Clark Type 100T Heavy Duty Push Buttons are available in Standard, Mushroom Head, Push Pull, and Key-Operated .

All units are suitable for use in NEMA Type 1, 3, 3R, 4, 4X, 12, and 13 applications when mounted in enclosures rated for those same applications. Although not needed on all Type 4X applications, protective caps provide improved resistance to some corrosive materials. They are not required by UL.

NEMA 13 Oiltight and NEMA 4 Watertight integrity is assured by a unique collapsing neoprene diaphragm. Three neoprene gaskets in back of the panel insure a tight fit and flexibility for different thickness enclosures. The die cast housing fits both standard Oiltight mounting holes with a 1-13/64" or 30.56mm diameter.

Single circuit double break contact blocks are made of tough clear plastic for easy contact inspection. Blocks are attached to the operator by a single captive screw and positioning pin to make installation quick and easy. Up to 8 blocks may be stacked on each push button operator (2 wide, 4 deep). Up to 6 blocks on each selector switch.

Brushed aluminum legend plates are held in place by a locking thrust washer which extends through the plate into the panel for easy alignment. Standard legend plates are 1-7/8" square with black etched in letters. Jumbo automotive size 2-1/2" square legends are also available.

Standard Operators

Interchangeable snap-on, reusable tough molded-in-plastic cups, are available in black, red, green, yellow, amber, blue, white, and brown. Your choice of three octagonal, brushed aluminum guard rings comes in:

Unguarded - Button extends beyond ring for easy access.

Guarded - Ring is flush with button to prevent accidental operation.

Extended - Ring extends beyond button Guard making accidental operation unlikely.

Standard and Jumbo Mushroom Head

Both mushroom heads fit the same operator and come in black, red, green, and yellow. The diameter of the standard head is 1-3/8" - jumbo head is 2-1/4" in diameter.

Illuminated Push Button

Plastic Lens are available in seven colors and in standard and mushroom head (1^{3/8}" variety. The operator combines a momentary push button and pilot light in one unit.

Push-Pull

Both Illuminated and Non-Illuminated standard mushroom heads are available in 2 position maintained operators.

Key-Operated

When the key-type cylinder lock is depressed with or without key inserted - the operator is locked down and can only be released by the key. A red jumbo mushroom head can be field or factory installed for emergency stop applications. Other types of key operations are obtainable.



Joslyn Clark Type 100T Heavy Duty Selector Switches are available in Standard Knob, Chrome Lever, Key-Operated, Joy Stick and Selector-Push.

The standard knob and chrome lever switches are obtainable with two, three and four position operators. They come in: 2 position maintained and spring return; 3 position maintained, spring return from right to center, left to center, right and left to center; and 4 position maintained. Key operated switches come in two or three position maintained and spring return and all 4 position switches are maintained.

There are several cams for all selector switches in order to accomplish numerous types of circuits. Positive indexing assures operating reliability.

Up to eight single circuit contact blocks - four on either side - may be attached to any operator with a single captive screw and positioning pin on each block.

A tip on the locking thrust washer extends through the legend plate to the panel, locking both plate and operator in position.

Legend plates are of brushed aluminum with etched black lettering. An octagonal aluminum guard ring locks operator on the panel adding to the look of quality.

Standard Knob

Interchangeable knobs are of high-impact plastic in black, red, green, yellow and blue. They fit tightly to an inner white knob which provides an easy-to-see white index mark for the cap.

Standard Knob Illuminated Selector Switch

Available with seven interchangeable colored lenses in both two position maintained and three position maintained and spring return.



Selector Switches

Chrome Lever

These selector switches have the same operating characteristics as the Standard Knob model. An extended chrome lever, 1-3/4" long, provides quick and positive operation with or without gloves.

Key-Operated

Key-operated switches have the same positive action as the Standard Knob and Chrome Lever types. Operators are obtainable with many key removal positions. There are special keys available for added security.

Joy Stick

All 3 position and 5 position maintained and spring return joy sticks have the same positive action as the other selector switches. A special joy stick model can be supplied with a release button on top. This prevents movement of the joy stick until the button is depressed - an excellent safety feature.

Selector-Push

Selector-Push operators combine the actions of a selector switch and momentary push button. A rotating collar provides the selectivity needed to provide for several functions in one operator.

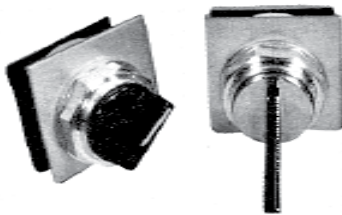

Pilot Lights

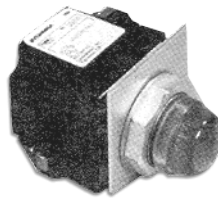

Joslyn Clark Type 100T Heavy Duty Pilot Lights are available in Standard and Press-To-Test. A choice of power configurations to match various shock and vibration levels insure longer lamp life. Plastic lenses come in red, green, yellow, amber, blue, white and clear. All lamps have bayonet type bases.

There are four basic power configurations.

- 1. Transformer Type (120, 240 or 480 Volts)** uses a modular heavy-duty transformer - 50 or 60 Hertz - to step line voltage down to 6 volts for longer lamp life under high shock and vibration conditions.
- 2. Resistor Type (120 or 240 Volts)** drops voltage to 60 and 120 volts respectively to lengthen lamp life in less severe applications.
- 3. Full-Voltage Types (6, 12, 24 or 120 Volts)** are used in applications with little shock or vibration. AC and DC rated.
- 4. Neon Type (120 Volts)** will withstand extremely heavy shock and vibration conditions - use of clear and yellow lens is recommended. AC and DC rated.

Standard

Dome Lenses are made of thick plastic, fluted to give wide visibility. They come in red, green, yellow, amber, blue, white and clear.

Press-To-Test

Features and colors are the same as Standard Pilot Lights except the lenses are tubular. A N.O. and a N.C. contact block comes with unit.

Contact Blocks (600 Volt)

Features

- Contacts enclosed in a clear plastic housing
- Fine silver contact tips
- Long life steel springs
- Same contact block for all operators
- "Quick-Stack" assembly
- "Easy-Access" terminals
- "One-Block-At-A-Time" removal
- Easy contact mode identification
- UL listed

Joslyn Clark Type 100T Heavy Duty Contact Blocks are designed to simplify installation and assure trouble-free operation.

Contacts are enclosed in sturdy plastic to prevent foreign material from entering the block. The clear plastic allows easy contact inspection. Contact tips are made of fine silver for high conductivity. Strong resilient springs reduce contact bounce and assure long reliable operation. The 3/4" blocks may be used on all operators installed side by side and four in tandem.

The single No. 8 tapped-head captive screw and positioning pin on each block make stacking fast and easy. Terminals are inclined for direct access and speedy wiring also angled to provide extra wiring room. A self-rising saddle assures a solid vibration resistant connection at each terminal for two No. 12 copper wires. Individual block removal is automatic without possibility of the entire stack coming off when the top block is removed.

Contact mode is readily identified. Normally-Open contact blocks have green operators marked with both N.O. and NO symbol. The normally-closed blocks have red operators and are marked with N.C. and NC symbol.



D

Push Buttons



Extended Pushbutton

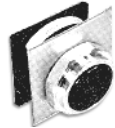

Flush Pushbutton



1-3/8 inch Mushroom Head

Pushbuttons Momentary Operation

NEMA Type 1, 4, 12, 13		
Operator	Color	Catalog Number
Extended	Black	100T-PB1B
	Red	100T-PB1R
	Green	100T-PB1G
	Yellow	100T-PB1Y
	Amber	100T-PB1A
	Blue	100T-PB1E
	White	100T-PB1W
	Brown	100T-PB1N
	None	100T-PB10
	Flush	Black
Red		100T-PB2R
Green		100T-PB2G
Yellow		100T-PB2Y
Amber		100T-PB2A
Blue		100T-PB2E
White		100T-PB2W
Brown		100T-PB2N
None		100T-PB20
1-3/8 inch Mushroom		Black
	Red	100T-PB4R
	Green	100T-PB4G
	Yellow	100T-PB4Y
	None	100T-PB40
2-1/4 inch Mushroom	Black	100T-PB5B
	Red	100T-PB5R
	Green	100T-PB5G
	Yellow	100T-PB5Y

Standard Contact Blocks

Type	Symbol	Rod Color	Catalog Number
1-N.O.		Green	100T-CB10
1-N.C.		Red	100T-CB01 100T-CBH01 ²
Standard Contact Block	1-N.O. & 1-N.C.	1-Green & 1-Red	100T-CB11 ¹

1. Consists of one 100T-CB10 and one 100T-CB01 packaged together.
2. Additional spring pressure for resistance to vibration.

Contact Ratings

NEMA Rating Desig.	Max. Volts	Amps.			VA.	
		Make	Break	Continuous	Make	Break
Maximum A-C Contact Rating Per Pole, 50 or 60 Hertz.						
A600	120	60	6	10	7200	720
	240	30	3			
	480	15	1.5			
	600	12	1.2			
Maximum D-C Contact Rating Per Pole						
P600	125	1.1		5	138	120
	250	0.55				
	301-600	0.2				

Pushbutton Color Caps and Mushroom Head

	Color Caps for Flush Unguarded or Guarded Push Buttons	1-3/8 inch Mushroom Head for Mushroom Buttons and Push Pull Units	2-1/4 inch Mushroom Head for Mushroom Buttons and Push Pull Units
Color	Catalog Number	Catalog Number	Catalog Number
Black	100T-BB	100T-BM4B	100T-BM5B
Red	100T-BR	100T-BM4R	100T-BM5R
Green	100T-BG	100T-BM4G	100T-BM5G
Yellow	100T-BY	100T-BM4Y	100T-BM5Y
Amber	100T-BA		
Blue	100T-BE		
White	100T-BW		
Brown	100T-BN		
Mixed	100T-BM	100T-BM4M	

Selection Guide

Select push button operators from table above and contact blocks from table on the right. Select legend plates from page D16.

For complete units see page D13. All units on this page will accept a total of eight contact blocks.

Item	Page	Item	Page
Accessories	D17	Pilot Lights	D7
Legend Plates	D16	Selector Switches	D8
Ratings and Dimensions	D18	Special Devices	D4
Assembled Units	D13	Assembled Stations	D13

Ordering Information

Complete Control Unit Consists Of:



Operator 100T-PB2B

+



Contact Blocks 100T-CB01

+

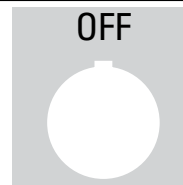

Legend Plate 100T-L07

=

Complete Push Button Unit

Special Purpose Push Button Units

Key Operated Push Button

This key operated push button is a chrome, unguarded unit that locks in the depressed position. It must be unlocked with a key to release it. Two keys are provided with each unit.

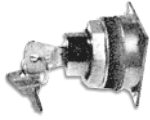

Key Operated Push Button

Description ¹	Catalog No.
Unit Locks in Depressed Position Key Required to Release Chrome Unit	100T-PB61 Legend Plate & Contact Blocks Not Included

1. 100T-BM6R 2 1/4 inch Red Mushroom Head available for this unit.

Standard Contact Blocks

Type	Symbol	Rod	Catalog
		Color	Number
1-N.O.		Green	100T-CB10
1-N.C.		Red	100T-CB01 100T-CBH01 ³
1-N.O. & 1-N.C.		1-Green & 1-Red	100T-CB11 ²

2. Consists of one 100T-CB10 and one 100T-CB01 packaged together.
3. Additional spring pressure for resistance to vibration.

Item	Page
Accessories	D17
Legend Plates	D16
Ratings and Dimensions	D18

Push-Pull Units

Push-Pull units are available as two position, maintained (buttons remain in the depressed position until manually released). Standard units have 1 3/8 inch mushroom head operator.

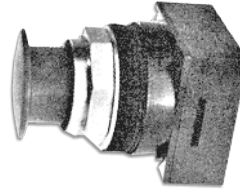

Push-Pull Unit

Push-Pull Units

Comes with 1 3/8 inch Standard Mushroom Head. Legend Plate and Contact Blocks not included.

Description	Color ⁴	Catalog Number
Maintained	Black	100T-PP4B
	Red	100T-PP4R
	None	100T-PP40

1. For colors not listed, or for units with 2 1/4 inch diameter Mushroom Heads, order with "none" and select desired Mushroom Head from below.

Mushroom Head Color Caps

	1-3/8 inch Mushroom Head for Mushroom Buttons and Push Pull Units	2-1/4 inch Mushroom Head for Mushroom Buttons and Push Pull Units
Color	Catalog Number ⁵	Catalog Number ⁶
Black	100T-BM4B	100T-BM5B
Red	100T-BM4R	100T-BM5R
Green	100T-BM4G	100T-BM5G
Yellow	100T-BM4Y	100T-BM5Y
Mixed	100T-BM4M	100T-BM5M

5. Packaged 1 per carton except 100T-BM4M contains one of each color.

6. Packaged 1 per carton except 100T-BM5M contains one of each color.

Ordering Information

Complete Control Unit Consists Of:

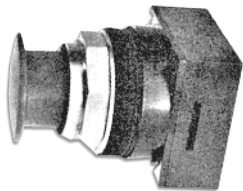

Operator
100T-PP4B

+



Contact Blocks
100T-CB01

+

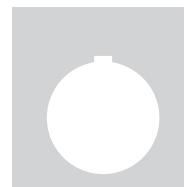

Legend Plate
100T-L30

=

Complete Push Button Unit

100T

Push Buttons



Illuminated Push Buttons

Illuminated Momentary Push Buttons comes with Standard Lens.
Legend Plate and Contact Blocks Not Included.

Operator & Lenses
100T-PBLT1R

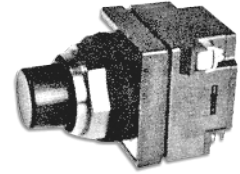

Type	Voltage	Lamp Number	Lens Color	Catalog Number ¹
Transformer	120 AC only 50/60 Hz	755	Red	100T-PBLT1R
			Green	100T-PBLT1G
			None	100T-PBLT10
	240 AC only 50/60 Hz	755	Red	100T-PBLT2R
			Green	100T-PBLT2G
			None	100T-PBLT20
480 AC only 50/60 Hz	755	Red	100T-PBLT4R	
		Green	100T-PBLT4G	
		None	100T-PBLT40	
Resistor	120 AC DC	60MB	Red	100T-PBLR1R
			Green	100T-PBLR1G
			None	100T-PBLR10
	240 AC DC	120MB	Red	100T-PBLR2R
			Green	100T-PBLR2G
			None	100T-PBLR20
Full Voltage	120 AC DC	120MB	Red	100T-PBLF1R
			Green	100T-PBLF1G
			None	100T-PBLF10
	6 AC DC	6MB	Red	100T-PBLF6R
			Green	100T-PBLF6G
			None	100T-PBLF60
	12 AC DC	12MB	Red	100T-PBLF7R
			Green	100T-PBLF7G
			None	100T-PBLF70
	24 AC DC	24MB	Red	100T-PBLF8R
			Green	100T-PBLF8G
			None	100T-PBLF80
Neon ²	120 AC DC	NE51	Yellow	100T-PBLN1Y
			Clear	100T-PBLN1C
			None	100T-PBLN10

Selection Guide

Select Illuminated push button operators from table at left and contact blocks from below. Units without lenses will accept either standard lens or mushroom lens. All units are provided with "unguarded" guard ring. Clear plastic guard 100T-PGR is available.

Select legend plates from page D16

For complete units, see page D13

All units on this page will accept a total of eight contact blocks.

Standard Contact Blocks

Type	Symbol	Rod Color	Catalog Number
Standard Contact Block	1-N.O.		Green 100T-CB10
	1-N.C.		Red 100T-CB01 100T-CBH01 ⁴
Standard Contact Block	1-N.O. & 1-N.C.		1-Green & 1-Red

3. Consists of one 100T-CB10 and one 100T-CB01 packaged together.

4. Additional spring pressure for resistance to vibration.

Standard Lenses and Mushroom Lenses

	Standard Lenses for Guarded or Unguarded Push Buttons or Press-to-Test Pilot Lights	1-3/8 inch Mushroom Lenses for Illuminated Push Buttons and Illuminated Push-Pull Units
Color	Catalog Number	Catalog Number
Red	100T-LBR	100T-LBMR
Green	100T-LBG	100T-LBMG
Yellow	100T-LBY	100T-LBMY
Amber	100T-LBA	100T-LBMA
Blue	100T-LBE	100T-LBME
White	100T-LBW	100T-LBMW
Clear	100T-LBC	100T-LBMC
Mixed	100T-LBM	100T-LBMM

5. Packaged one per carton except 100T-LBM contains seven lenses, one of each color.

6. Packaged one per carton except 100T-LBMM contains seven lenses, one of each color.

1. Catalog number with lens are for standard lens. For colors not listed, or for 1 3/8 inch mushroom lens, order with "none" and select desired standard or mushroom lens from table at right.

2. Yellow or clear lens only recommended for neon unit.

Item	Page
Accessories	D17
Legend Plates	D16
Ratings and Dimensions	D18
Assembled Units	D13

Replacement Lamps	
Voltage	Catalog #
6V	080 MB1
12V	080 MB2
24V	080 MB3
48V	080 MB5
120V	080 MB7

Ordering Information

Complete Control Unit Consists Of:

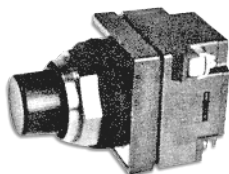

Operator
100T-PBLT1R

+



Contact Blocks
100T-CB01

+

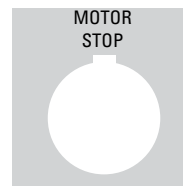

Legend Plate
100T-L92

=

Complete
Push Button
Unit



Illuminated Push-Pull Units

Illuminated Push-Pull Units (Maintained Position) Comes With and Without 1 3/8 inch Mushroom Head.
Legend Plate and Contact Blocks Not Included.

Type	Voltage	Lamp Number	Lens Color	Catalog Number ¹
Transformer	120 AC only 50/60 Hz	755	Red	100T-PPLT1R
			Green	100T-PPLT1G
			None	100T-PPLT10
	240 AC only 50/60 Hz	755	Red	100T-PPLT2R
			Green	100T-PPLT2G
			None	100T-PPLT20
480 AC only 50/60 Hz	755	Red	100T-PPLT4R	
		Green	100T-PPLT4G	
		None	100T-PPLT40	
Resistor	120 AC DC	60MB	Red	100T-PPLR1R
			Green	100T-PPLR1G
			None	100T-PPLR10
	240 AC DC	120MB	Red	100T-PPLR2R
			Green	100T-PPLR2G
			None	100T-PPLR20
Full Voltage	120 AC DC	120MB	Red	100T-PPLF1R
			Green	100T-PPLF1G
			None	100T-PPLF10
	6 AC DC	6MB	Red	100T-PPLF6R
			Green	100T-PPLF6G
			None	100T-PPLF60
	12 AC DC	12MB	Red	100T-PPLF7R
			Green	100T-PPLF7G
			None	100T-PPLF70
	24 AC DC	24MB	Red	100T-PPLF8R
			Green	100T-PPLF8G
			None	100T-PPLF80
Neon ²	120 AC DC	NE51	Yellow	100T-PPLN1Y
			Clear	100T-PPLN1C
			None	100T-PPLN10

1. For colors not listed, order with "none" and select desired mushroom lens form table at right.
2. Yellow or clear lens only recommended for neon unit.

Item	Page
Accessories	D17
Legend Plates	D16
Ratings and Dimensions	D18

Operator & Lenses
100T-PPLT1R

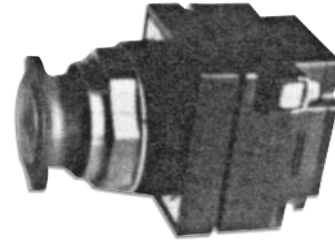

Selection Guide

Illuminated push-pull units are two position illuminated mushroom buttons which remain in the depressed position until manually released. Select the operator from table at left and contacts from below. Select legend plate from page D16.

All units on this page will accept a total of eight contact blocks.

Standard Contact Blocks

Type	Symbol	Rod		Catalog Number
		Color		
1-N.O.		Green		100T-CB10
1-N.C.		Red		100T-CB01 100T-CBH01 ⁴
1-N.O. & 1-N.C.		1-Green & 1-Red		100T-CB11 ³

3. Consists of one 100T-CB10 and one 100T-CB01 packaged together.
4. Additional spring pressure for resistance to vibration.

Mushroom Lenses for Illuminated Push-Pull Units

Color	1 3/8 inch Mushroom Lenses for Illuminated Push-Pull Units
	Catalog Number
Red	100T-LBMR
Green	100T-LBMG
Yellow	100T-LBMY
Amber	100T-LBMA
Blue	100T-LBME
White	100T-LBMW
Clear	100T-LBMC
Mixed	100T-LBMM

5. Packaged one per carton except 100T-LBMM contains seven lenses, one of each color.

Ordering Information

Complete Control Unit Consists Of:



Operator
100T-PPLT1R

+



Contact Blocks
100T-CB01

+

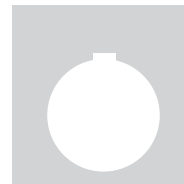

Legend Plate
100T-L30

=

Complete
Push Button
Unit



Pilot Lights and Press-To-Test Pilot Lights

				Pilot Lights ⁴	Press-To-Test ⁴	
Type	Voltage	Lamp Number	Lens Color	Catalog Number ¹	Catalog Number ³	
Transformer	120 AC only 50/60 Hz	755	Red Green None	100T-PLT1R 100T-PLT1G 100T-PLT10	100T-PTT1R 100T-PTT1G 100T-PTT10	
	240 AC only 50/60 Hz	755	Red Green None	100T-PLT2R 100T-PLT2G 100T-PLT20	100T-PTT2R 100T-PTT2G 100T-PTT20	
	480 AC only 50/60 Hz	755	Red Green None	100T-PLT4R 100T-PLT4G 100T-PLT40	100T-PTT4R 100T-PTT4G 100T-PTT40	
	Resistor	120 AC DC	60MB	Red Green None	100T-PLR1R 100T-PLR1G 100T-PLR10	100T-PTR1R 100T-PTR1G 100T-PTR10
		240 AC DC	120MB	Red Green None	100T-PLR2R 100T-PLR2G 100T-PLR20	100T-PTR2R 100T-PTR2G 100T-PTR20
		Full Voltage	120 AC DC	120MB	Red Green None	100T-PLF1R 100T-PLF1G 100T-PLF10
6 AC DC	6MB		Red Green None	100T-PLF6R 100T-PLF6G 100T-PLF60	100T-PTF6R 100T-PTF6G 100T-PTF60	
12 AC DC	12MB		Red Green None	100T-PLF7R 100T-PLF7G 100T-PLF70	100T-PTF7R 100T-PTF7G 100T-PTF70	
24 AC DC	24MB		Red Green None	100T-PLF8R 100T-PLF8G 100T-PLF80	100T-PTF8R 100T-PTF8G 100T-PTF80	
Neon ²	120 AC DC	NE51	Yellow	100T-PLN1Y	100T-PTN1Y	
			Clear	100T-PLN1C	100T-PTN1C	
			None	100T-PLN10	100T-PTN10	

- For colors not listed, order with "none" and select desired lens from table below.
- Yellow or clear lens only recommended for neon unit.
- Catalog number with lens are for standard lens. For colors not listed or for 1 3/8 inch mushroom lens order with "none" and select desired standard or mushroom lens from table below.
- Legend Plate Not Included.
- For Replacement Lamps see page D6.

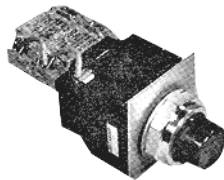

Press-To-Test Pilot Light
Operator & Lens
100T-PTT1R

Standard Lens

Pilot Light
Operator & Lens
100T-PLT1R

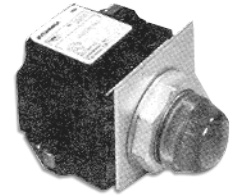

Pilot Light

Pilot Lights are available in four different power configurations - transformer, resistor, full voltage and neon types. Transformer types are available with 480, 240, and 120 volt primary voltages and all have a 6.3 volt secondary for long lamp life. They will withstand a considerable amount of shock and vibration. The resistor type is available in 240 and 120 volt varieties with the resistor dropping the voltage to 120 and 60 volts respectively. Full voltage units are available with 6, 12, 24, and 120 volt lamps. The neon bulbs burn less brightly therefore it is recommended that only yellow and clear lens be used for these units.

Press-To-Test Lights

Press-To-Test Lights are available in the same four power configurations as the standard pilot lights - Transformer, resistor, full voltage, and neon. They are furnished pre-wired with a normally open and a normally closed contact. As shown in the diagram below it will allow you to test the lamp without interfering with the normal operation of the pilot light.

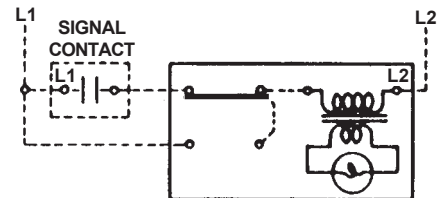

Standard Lenses and Mushroom Lenses

Color	Standard Lenses for Pilot Lights (Purchased after Jan. 1997)	Standard Lenses for Guarded or Unguarded Buttons or Press-To-Test Pilot Lights	1 3/8 inch Mushroom Lenses for Illuminated Press-To-Test Pilot Lights
	Catalog Number	Catalog Number	Catalog Number
Red	100T-LR	100T-LBR	100T-LBMR
Green	100T-LG	100T-LBG	100T-LBMG
Yellow	100T-LY	100T-LBY	100T-LBMY
Amber	100T-LA	100T-LBA	100T-LBMA
Blue	100T-LE	100T-LBE	100T-LBME
White	100T-LW	100T-LBW	100T-LBMW
Clear	100T-LC	100T-LBC	100T-LBMC
Mixed	100T-LM	100T-LBM	100T-LBMM

5. Packaged 1 per carton except 100T-LM contains seven lenses one of each color.
6. Packaged 1 per carton except 100T-LBM contains seven lenses one of each color.
7. Packaged 1 per carton except 100T-LBMM contains seven lenses one of each color.



Selector Switches 2-3-4 Position Non-Illuminated

Selector Switches

Legend Plate and Contact Blocks not included

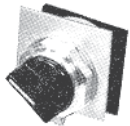

**Black Knob
100T-SS2MB1**

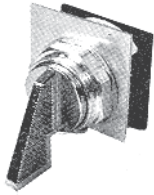

**Chrome Lever
100T-SL2MC1**

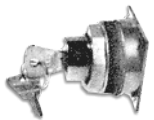

**Key Operated
100T-SK3M**

Type	Black Knob Operator ^{1,2}		Chrome Lever Operator		Key Operator		
	Catalog Number	Cam ³ Code	Catalog Number	Cam ³ Code	Catalog Number	Cam ³ Code	Key ⁴ Removal
2 Positioned Maintained	100T-SS2MB	1	100T-SL2MC	1	100T-SK2M	1	A
2 Position Spring Return Right To Center	100T-SS2RB	1	100T-SL2RC	1	100T-SK2R	1	C
3 Positioned Maintained	100T-SS3MB	3,4,5, 6, or 7	100T-SL3MC	3,4,5, 6, or 7	100T-SK3M	3,4,5, 6, or 7	A
3 Position Spring Return Right To Center	100T-SS3RB	3,4,5, 6, or 7	100T-SL3RC	3,4,5, 6, or 7	100T-SK3R	3,4,5, 6, or 7	C
3 Position Spring Return Left To Center	100T-SS3LB	3,4,5, 6, or 7	100T-SL3LC	3,4,5, 6, or 7	100T-SK3L	3,4,5, 6, or 7	C
3 Position Spring Return Rt. & Lt. to Ctr.	100T-SS3BB	3,4,5, 6, or 7	100T-SL3BC	3,4,5, 6, or 7	100T-SK3B	3,4,5, 6, or 7	C
4 Position Maintained	100T-SS4MB	8	100T-SL4MC	8	100T-SK4M	8	A

1. Available in other colors Change "B" in operator catalog number to "R" for Red, "G" for Green, "Y" for Yellow, or "E" for Blue.
2. Available without Knob Change "B" in operator Catalog number to "O" and select knob from table below.
3. Cam code is a part of catalog number: Example 100T-SS3MB3 See table of cam developments.
4. Key Removal code is part of catalog number. Example: 100T-SK3B3C See Key Removal table below.

Key Spare Parts

- For Standard Key Operator use 100T-3095
- For 501 Key Operator use 100T-CH501

Key Removal Codes

Key Removal Code	Two Position				Three Position			Four Position			
	Maintained		Spring Return		Left	Center	Right	Left	Left Center	Right Center	Right
	Left	Right	Center	Right							
L (Left)	Yes	No	-----	-----	Yes	No	No	Yes	No	No	No
R (Right)	No	Yes	No	Yes	No	No	Yes	No	No	No	Yes
C (Center)	-----	-----	Yes	No	No	Yes	No	-----	-----	-----	-----
A (All)	Yes	Yes	Yes	Yes	Yes	Yes	Yes	Yes	Yes	Yes	Yes

Notes: No 501 Key is available for above Key Operators Selector Switches. To order add "5" for 501 Key to the end of the catalog number. Example: 100T-SK2M1A5.

Color Plastic Knobs

Color	Standard Plastic Knob for Knob Operated Selector Switches
	Catalog Number
Black	100T-SB
Red	100T-SR
Green	100T-SG
Yellow	100T-SY
Blue	100T-SE
Mixed	100T-SM

Packaged one per carton except 100T-SM contains one of each color knob.

Ordering Information

Complete Control Unit Consists Of:

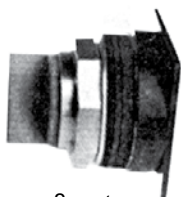

Operator
100T-SS2MB1

+



Contact Blocks
100T-CB01

+



Legend Plate
100T-L52

=

Complete
Push Button
Unit

100T

Push Buttons



Selector Switches Contact Block Switching Sequence and Selection

2 Position Selector Switch

Location of Contact Block (Front View)		Contact Block			Selector Position Cam Code 1			
					Maintained		Spring Return	
		Catalog Number 100T-	Symbol	Rod Color	Left	Right	Center	Right
Left	N.O.	CB10	<u>○, ○</u>	Green	○	X	○	X
	N.C.	CB01	<u>○ ○</u>	Red	X	○	X	○
Right	N.O.	CB10	<u>○, ○</u>	Green	○	X	○	X
	N.C.	CB01	<u>○ ○</u>	Red	X	○	X	○



Cam codes are same for maintained or spring return operation.

X = Contact Closed
○ = Contact Open

3 Position Selector Switch

Location of Contact Block (Front View)		Contact Block			Selector Position Cam Code 3			Selector Position Cam Code 4			Selector Position Cam Code 5			Selector Position Cam Code 6			Selector Position Cam Code 7			
					Left	Center	Right	Left	Center	Right	Left	Center	Right	Left	Center	Right	Left	Center	Right	
		Catalog Number 100T-	Symbol	Rod Color	↙	↑	↘	↙	↑	↘	↙	↑	↘	↙	↑	↘	↙	↑	↘	
Left	N.O.	CB10	<u>○, ○</u>	Green	○	○	X	○	○	X	X	○	○	○	○	○	X	○	○	X
	N.C.	CB01	<u>○ ○</u>	Red	X	○	○	○	X	○	○	X	○	X	X	○	X	○	○	○
Right	N.O.	CB10	<u>○, ○</u>	Green	○	○	X	○	○	X	X	○	○	X	○	○	○	○	○	X
	N.C.	CB01	<u>○ ○</u>	Red	X	○	○	○	X	○	○	X	○	○	X	X	○	X	○	○

Cam Codes are the same for maintained or spring return operation.

X = Contact Closed
○ = Contact Open

Item	Page
Accessories	D17
Legend Plates	D16
Ratings and Dimensions	D18
Assembled Units	D14

Standard Contact Blocks

Type	Symbol	Rod Color	Catalog Number
1-N.O.	<u>○, ○</u>	Green	100T-CB10
1-N.C.	<u>○ ○</u>	Red	100T-CB01 100T-CBH01 ²
1-N.O. & 1-N.C.	<u>○, ○</u> <u>○ ○</u>	1-Green & 1-Red	100T-CB11 ¹

1. Consists of one 100T-CB10 and one 100T-CB01 packaged together.
2. Additional spring pressure for resistance to vibration.

4 Position Selector Switch

Location of Contact Block (Front View)		Contact Block			Selector Position Cam Code 8			
					Left	Left Center	Right Center	Right
		Catalog Number 100T-	Symbol	Rod Color	←	↙	↘	→
Left	N.O.	CB10	<u>○, ○</u>	Green	○	○	X	○
	N.C.	CB01	<u>○ ○</u>	Red	X	○	○	○
Right	N.O.	CB10	<u>○, ○</u>	Green	○	X	○	○
	N.C.	CB01	<u>○ ○</u>	Red	○	○	○	X

Cam codes are same for maintained or spring return operation.

X = Contact Closed
○ = Contact Open



Assembled Push Buttons

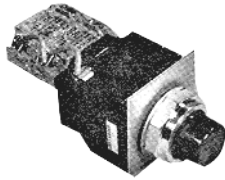

Assembled Push Buttons, including Contact Blocks as shown. (Does not include Legend Plate)				
Operator	Type	Symbol	Red Color	Catalog Number
Unguarded	1-N.O.		Black	100T-PB1B-10X
	1-N.C.		Red	100T-PB1R-01X
	1-N.C.		Black	100T-PB1B-11X
	1-N.O.		Red	100T-PB1R-11X
Guarded	1-N.O.		Black	100T-PB2B-10X
	1-N.C.		Black	100T-PB2B-11X
			Red	100T-PB2R-11X
1-N.O.		Green	100T-PB2G-11X	
1 3/8" Mushroom	1-N.C.		Black	100T-PB4B-11X
	1-N.O.		Red	100T-PB4R-11X
2 1/4" Mushroom	1-N.C.		Black	100T-PB5B-11X
	1-N.O.		Red	100T-PB5R-11X
Illuminated Push Button 120V Transformer Type	1-N.C.		Red	100T-PBLT1R-11X
	1-N.O.			
Illuminated Push Button 120V Resistor Type	1-N.C.		Red	100T-PBLR1R-11X
	1-N.O.			



Assembled 100T Push Button Stations

The most commonly used push button stations are available assembled in NEMA Type 13 (oiltight and dusttight) sheet steel and in NEMA 4 (watertight) stainless steel enclosures.

For custom control stations not listed, order operators, contact blocks, nameplates, and enclosures as separate items.

Assembled Push Buttons Stations

Assembled Push Buttons Stations In Surface mounted Enclosures		
Description of Elements	NEMA 13 ¹ Sheet Steel	NEMA 4 ² Stainless Steel
	Catalog Number	Catalog Number
Single element Stations START (black guarded push button)	100T-S1-1	100T-W1-1
START (black 2 1/4" mushroom push button)	100T-S1-2	100T-W1-2
STOP (red unguarded push button)	100T-S1-3	100T-W1-3
STOP (red Mushroom unguarded push button with lockdown)	100T-S1-4	100T-W1-4
STOP (red 2 1/4" mushroom push button)	100T-S1-5	100T-W1-5
OFF-ON (black knob selector switch)	100T-S1-6	100T-W1-6
HAND-OFF-AUTO (black knob selector switch)	100T-S1-7	100T-W1-7
FWD-OFF-REV (black knob selector switch)	100T-S1-8	100T-W1-8
Two Element Stations START-STOP (black guarded-red unguarded push buttons)	100T-S2-1	100T-W2-1
START-STOP (black guarded-red 1 3/8" mushroom push buttons)	100T-S2-2	100T-W2-2
FORWARD-REVERSE (black guarded-black guarded push buttons)	100T-S2-3	100T-W2-3
OPEN-CLOSE (black guarded-black guarded push buttons)	100T-S2-4	100T-W2-4
UP-DOWN (black guarded-black guarded push buttons)	100T-S2-5	100T-W2-5
Three Element Stations FORWARD-REVERSE-STOP (black guarded-black guarded-red unguarded push buttons)	100T-S3-1	100T-W3-1
OPEN-CLOSE-STOP (black guarded-black guarded-red unguarded push buttons)	100T-S3-2	100T-W3-2
UP-DOWN-STOP (black guarded-black guarded-red unguarded push buttons)	100T-S3-3	100T-W3-3
START-STOP-JOG (black guarded-red unguarded-black guarded push buttons)	100T-S3-4	100T-W3-4
START-STOP-MOTOR RUN (black guarded-red unguarded push buttons-red 120 volt transformer unguarded pilot light)	100T-S3-5	100T-W3-5

1. Use NEMA 13 enclosures for applications requiring NEMA 1.
2. Protective watertight boots are not required for indoor (non-freezing) applications. If for outdoor (freezing) use, order boots as separate items, from page D17.

100T

Push Buttons



Assembled Selector Switches

Assembled Selector Switches, Including Contact Blocks as shown

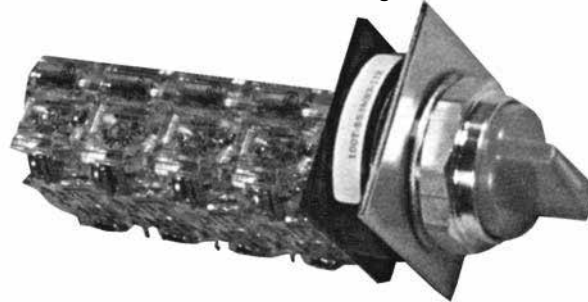

D

2 Position Selector Switch (Does not include Legend Plate)

Type	Location (Front View)	Contacts		Selector Position (Front View)			Complete Catalog No. and for Assembled Unit	
		Type and Symbol	Rod Color	Left	Center	Right	Black Knob Operator Catalog No.	Chrome Lever Operator Catalog No.
				←	↑	→		
2 Position Maintained	Left	N.O. ○ ○	Green	○	—	X	100T-	100T-
		N.C. ○ ○	Red	X	—	○	SS2MB1-11X	SL2MC1-11X
2 Position Spring Return Right to Center	Left	N.O. ○ ○	Green	—	○	X	100T-	100T-
		N.C. ○ ○	Red	—	X	○	SS2RB1-11X	SL2RC1-11X

3 Position Selector Switch (Does not include Legend Plate)

Type	Location (Front View)	Contacts		Selector Position (Front View)			Complete Catalog No. and for Assembled Unit	
		Type and Symbol	Rod Color	Left	Center	Right	Black Knob Operator Catalog No.	Chrome Lever Operator Catalog No.
				←	↑	→		
3 Position Maintained	Left	N.O. ○ ○	Green	○	○	X	100T-	100T-
		N.C. ○ ○	Red	X	○	○	SS3MB3-11X	SL3MC3-11X
3 Position Spring Return Right & Left to Center	Left	N.O. ○ ○	Green	○	○	X	100T-	100T-
		N.C. ○ ○	Red	X	○	○	SS3BB3-11X	SL3BC3-11X

4 Position Selector Switch (Does not include Legend Plate)

Type	Location (Front View)	Contacts		Selector Position (Front View)				Complete Catalog No. and for Assembled Unit	
		Type and Symbol	Rod Color	Left	Left Center	Right Center	Right	Black Knob Operator Catalog No.	Chrome Lever Operator Catalog No.
				←	↙	↘	→		
4 Position Maintained	Left	N.O. ○ ○	Green	○	○	X	○	100T- SS4MB8-22X	100T- SL4MC8-22X
		N.C. ○ ○	Red	X	○	○	○		
	Left	N.O. ○ ○	Green	○	X	○	○		
		N.C. ○ ○	Red	○	○	○	X		

Separate Enclosures

NEMA Type 13, and NEMA Type 4 Stainless Steel surface mounting enclosures are available with from one through sixteen element openings. All enclosures will accommodate non-illuminated operators with up to two contact blocks (1 per side). Consult factory for stations with 7 through 16 elements.

NEMA 13, Sheet Steel NEMA 4, Stainless Steel

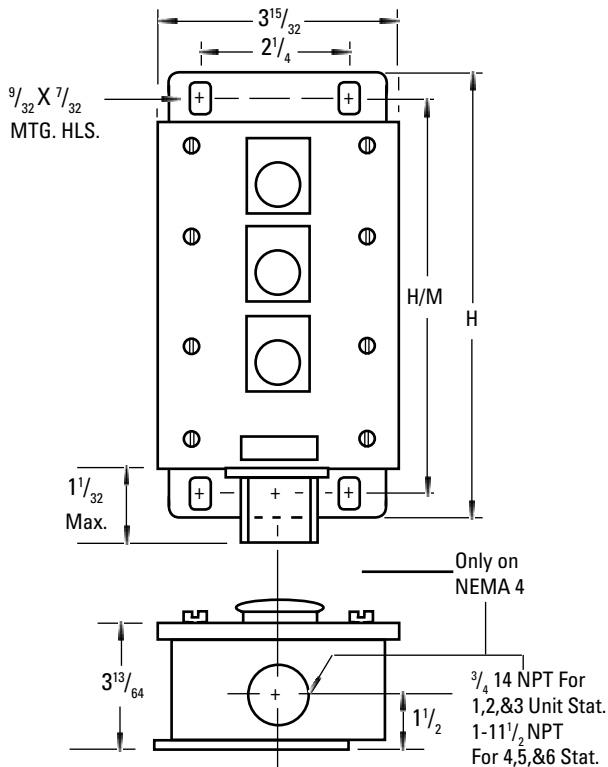

Separate Enclosures

Enclosures Only, Without Elements		
	NEMA 13 ¹ Sheet Steel Surface Mounted Enclosure	NEMA 4 ² Stainless Steel Surface Mounted Enclosure
Number Of Elements	Catalog Number	Catalog Number
1	100T-S1	100T-W1
2	100T-S2	100T-W2
3	100T-S3	100T-W3
4	100T-S4	100T-W4
5	100T-S5	100T-W5

1. Use NEMA 13 enclosures for applications requiring NEMA 1.
2. Protective watertight boots are not required for indoor (non-freezing) applications. If for outdoor (freezing) use, order boots as separate items from page D17.

NEMA 13, Sheet Steel					
Number of Elements	Surface Mounted Enclosure				
	W	H	D	W/M	H/M
1		6- ¹³ / ₁₆			6- ¹ / ₄
2		6- ¹³ / ₁₆			6- ¹ / ₄
3	3- ¹⁵ / ₃₂	9- ¹ / ₁₆	3- ¹³ / ₆₄	2- ¹ / ₄	8- ¹ / ₂
4		11- ⁵ / ₁₆			10- ³ / ₄
5		15- ¹ / ₁₆			14- ¹ / ₂

NEMA 4, Stainless Steel					
Number of Elements	Surface Mounted Enclosure				
	W	H	D	W/M	H/M
1		6- ¹³ / ₁₆			6- ¹ / ₄
2		9- ¹ / ₁₆			8- ¹ / ₂
3	3- ¹⁵ / ₃₂	11- ⁵ / ₁₆	3- ¹³ / ₆₄	2- ¹ / ₄	10- ³ / ₄
4		13- ³ / ₁₆			12- ⁵ / ₈
5		15- ¹ / ₁₆			14- ¹ / ₂

Ordering Information

- Select enclosure desired by catalog number.
- Select Pilot Devices from 100T section.

100T

Push Buttons

Legend Plates

Standard Legend Plates - Available with markings listed below.

Non-Standard Legend Plates - Can be provided with special markings.



D

Marking	Catalog No. Standard Size 1-7/8" Square ¹	Catalog No. Jumbo Size 2-1/2" Square ²
For Push Buttons and Pilot Devices		
Start	100T-L01	100HF-N701
Stop	100T-L02	100HF-N702
Fast	100T-L03	100HF-N703
Slow	100T-L04	100HF-N704
Open	100T-L05	100HF-N705
Close	100T-L06	100HF-N706
Off	100T-L07	100HF-N707
On	100T-L08	100HF-N708
Up	100T-L09	100HF-N709
Down	100T-L10	100HF-N710
Raise	100T-L11	100HF-N711
Lower	100T-L12	100HF-N712
Low	100T-L13	100HF-N713
High	100T-L14	100HF-N714
Out	100T-L15	100HF-N715
In	100T-L16	100HF-N716
Jog	100T-L17	100HF-N717
Inch	100T-L18	100HF-N718
Reset	100T-L19	100HF-N719
Run	100T-L20	100HF-N720
Forward	100T-L21	100HF-N721
Reverse	100T-L22	100HF-N722
Jog Forward	100T-L23	100HF-N723
Jog Reverse	100T-L24	100HF-N724
Emergency Stop	100T-L25	100HF-N725
Push Stop	100T-L41	100HF-N741
Pull Start		
Cycle Start	100T-L83	100HF-N783
Cycle Stop	100T-L84	100HF-N784
Power On	100T-L91	100HF-N791
Motor Run	100T-L92	100HF-N792
Motor Stop	100T-L93	100HF-N793
Light Indicates Motor Running	100T-L94	100HF-N794
(Blank)	100T-L30	100HF-N730

Marking	Catalog No. Standard Size 1-7/8" Square ¹	Catalog No. Jumbo Size 2-1/2" Square ²
For Two Position Selector Switches		
Man-Auto	100T-L51	100HF-N751
Off-On	100T-L52	100HF-N752
For-Rev	100T-L53	100HF-N753
Safe-Run	100T-L54	100HF-N754
Jog-Run	100T-L55	100HF-N755
High-Low	100T-L56	100HF-N756
Open-Close	100T-L57	100HF-N757
Up-Down	100T-L58	100HF-N758
Hand-Auto	100T-L59	100HF-N759
Start-Stop	100T-L60	100HF-N760
Run-Jog	100T-L61	100HF-N761
Start-Jog	100T-L62	100HF-N762
For Three Position Selector Switch		
Hand-Off-Auto	100T-L71	100HF-N771
Auto-Off-Hand	100T-L72	100HF-N772
For-Off-Rev	100T-L73	100HF-N773
Open-Off-Close	100T-L74	100HF-N774
Man-Off-Close	100T-L75	100HF-N775
For-Safe-Rev	100T-L76	100HF-N776
Run-Safe-Jog	100T-L77	100HF-N777
Jog-Safe-Run	100T-L78	100HF-N778
Up-Off-Down	100T-L79	100HF-N779
For Four Position Selector Switches		
1-2-3-4	100T-L31	100HF-N731
For Joy Stick Operator		
(Blank)	100T-L30	100HF-N730

1. Character height is 1/8 inch on Standard Legend Plate.

2. Character height is 1/4 inch on Jumbo Legend Plate.

Notes:

Use the trim washer if no legend plate is used. Discard the trim washer when using a legend plate.



Accessories

Description		Catalog Number
	Guard Rings for Push Buttons Unguarded Guarded Extended Guard Standard Mushroom Head Guard Jumbo Head Guard Half Guarded	100T-1GR 100T-2GR 100T-3GR 100T-4GR 100T-5GR 100T-7GR
	Lens Guard for Press-To-Test Pilot Lights Plastic Metal	100T-PGR 100T-MGR
	Water Resistant Boots for Push Buttons Black Red Green Yellow Translucent	100T-PBB 100T-PBR 100T-PBG 100T-PBY 100T-PBT
	Translucent Water Resistant Boots for Illuminated Push Buttons, Pilot Lights, and Press-To-Test Pilot Lights	100T-PLTB

D

100T

Push Buttons



Dimensions and Ratings

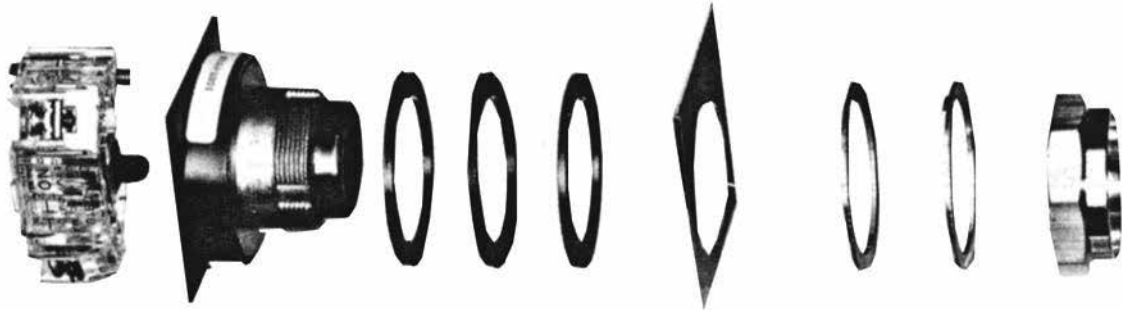

D

Minimum Centerline Clearance

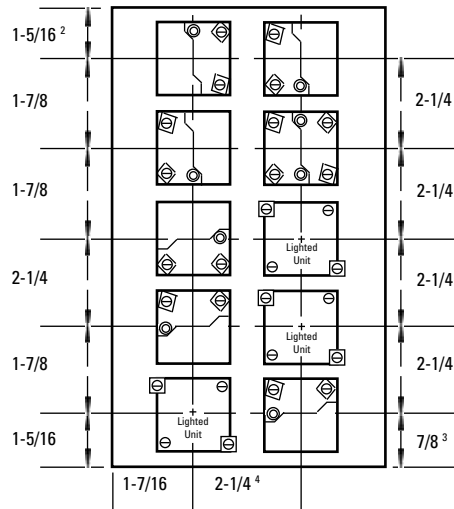

Enclosure or grounded metal part

Panel Drilling

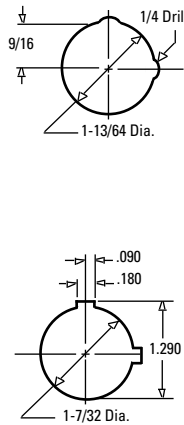

Contact Ratings

NEMA Rating	Max. Volts	Amp. Rating			VA.	
		Make	Break	Continuous	Make	Break
Maximum A-C Contact Rating Per Pole, 50 or 60 Hertz						
A600	120	60	6	10	7200	720
	240	30	3			
	480	15	1.5			
	600	12	1.2			
Maximum D-C Contact Rating Per Pole						
P600	125	1.1		5	138	
	250	0.55			138	
	301-600	0.2			120	

Max. Panel Thickness, In.	Spacers Required
1/16	3
1/8	2
3/16	1

Panels thicker than 3/16" must be Counter Bored

Depth Behind Panel	Push Buttons & Selector Switches	Push-Pull Units (Non-Illuminated)	Illuminated Units (all)
A ⁵	21/32	1-11/32	11/16
B	---	---	1-3/32
C ⁶	3/4	3/4	3/4

Notes:

1. Use the trim washer if no legend plate is used. Discard the trim washer when using a legend plate.
2. Must be 1-5/8" for 100-HF Legend Plate
3. Must be 1-1/8" for 2-1/4" Mushroom Head
4. When using 100-HF Legend Plate, both horizontal and vertical centerlines between operators must be 2-1/2" min.
5. When using either 2-1/4" mushroom head or lever selector switch, both horizontal and vertical centerlines between operators must be 2-1/4" min.
6. Depth when three neoprene spacers are used. Reduce depth by 1/16 inch for each spacer omitted.
7. Depth per contact block. Maximum contact stack depth is three (3) inches.

Rear of Mounting Panel

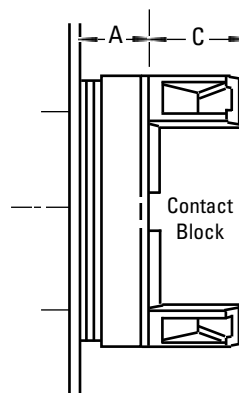

Rear of Mounting Panel

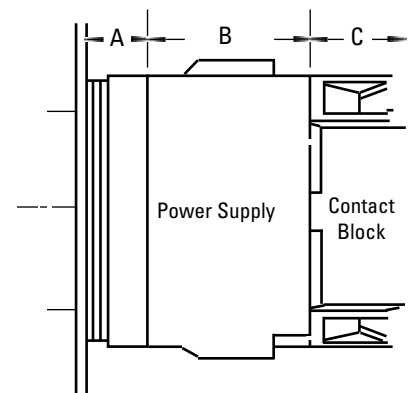

Catalog Numbering System

Push Button & Push-Pull

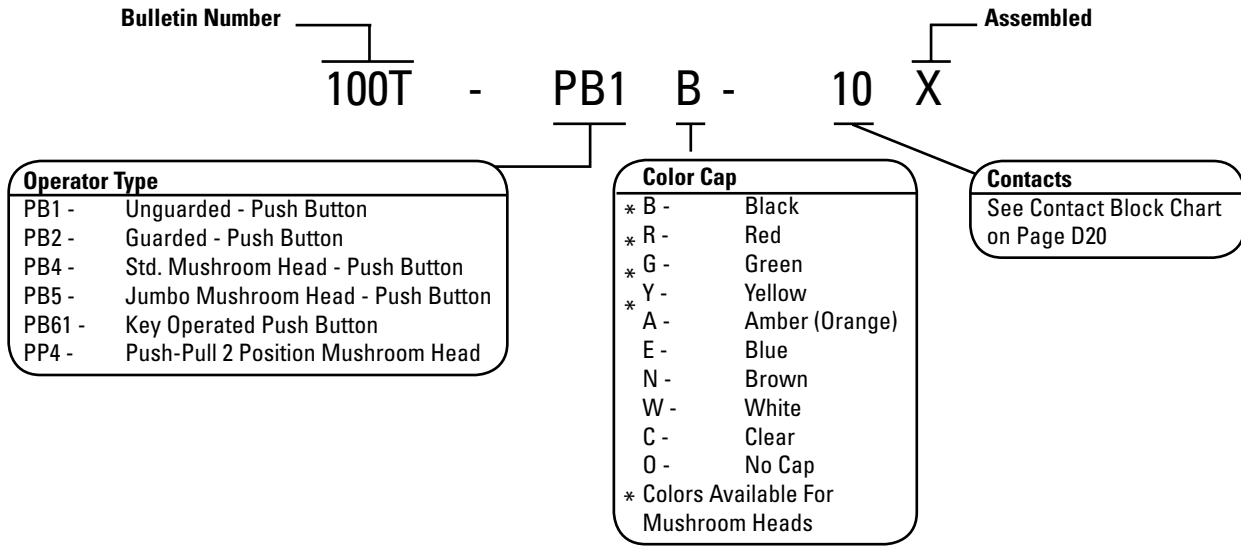

Selector Switch

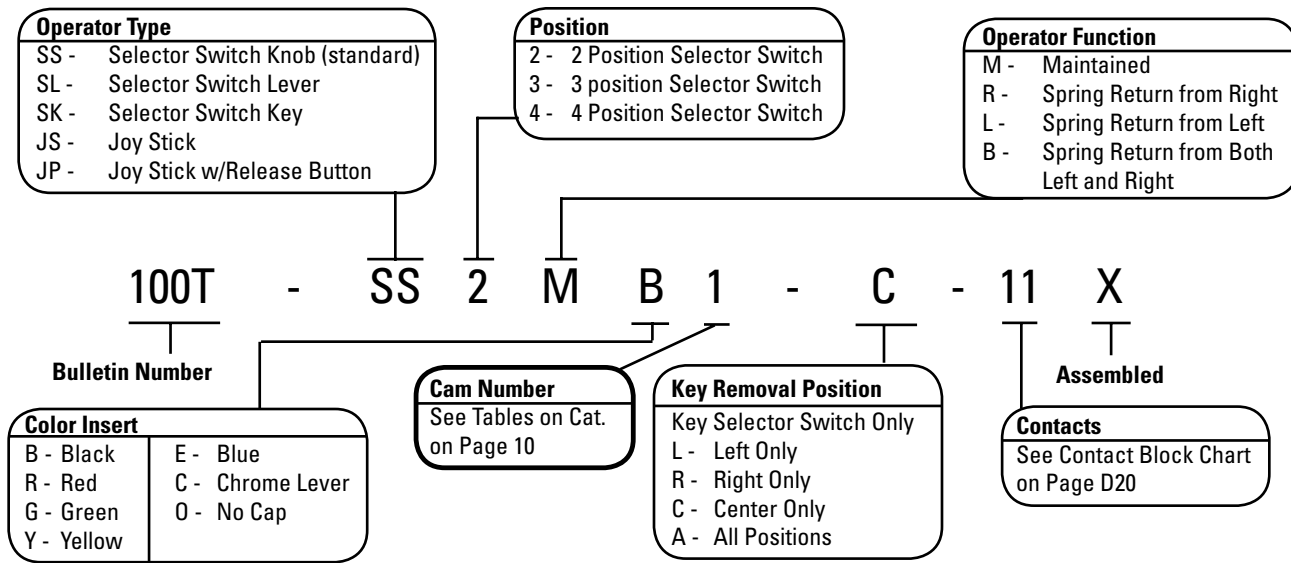

Pilot Lights & Press To Test Lights

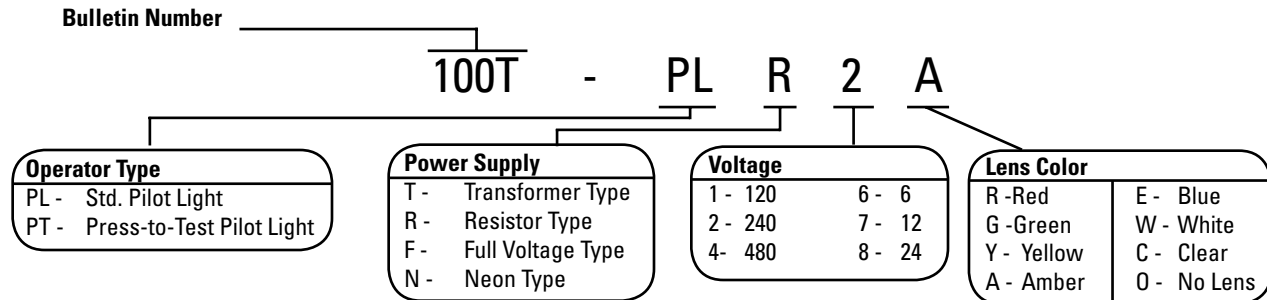

D

Catalog Numbering System

Illuminated Push Button & Push-Pull

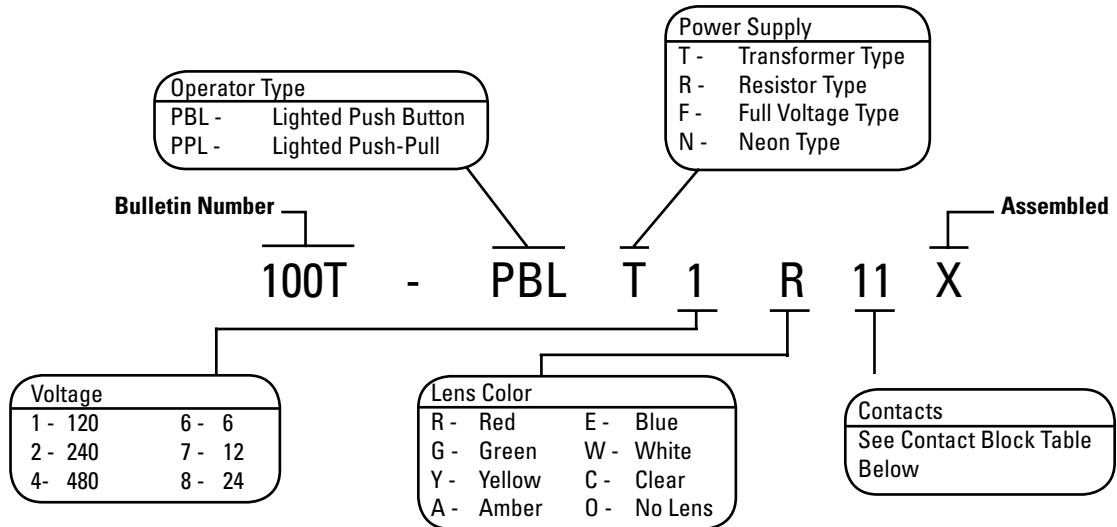

Illuminated Selector Switch

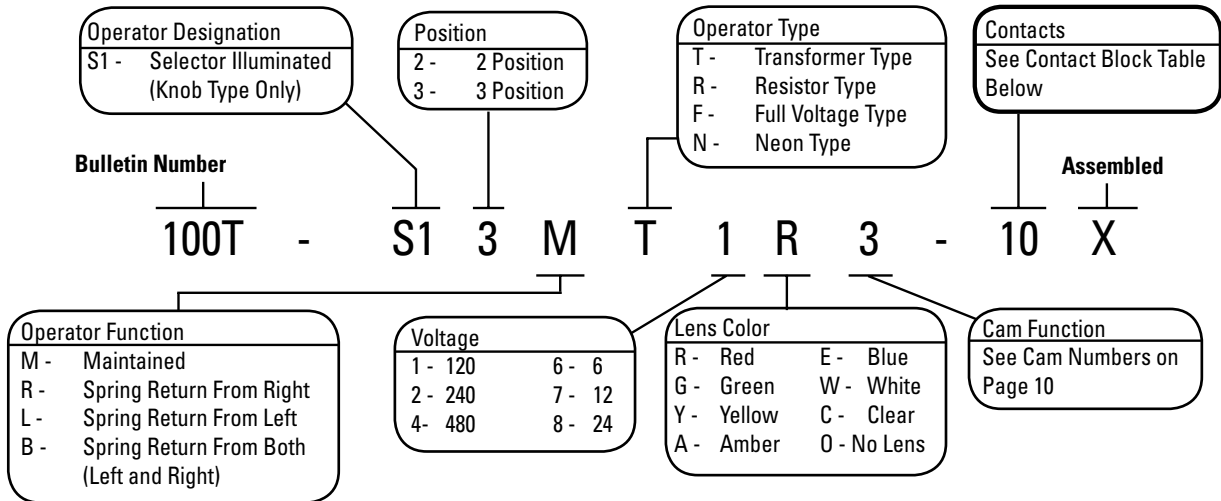

Contact Table

For This Contact Arrangement	Catalog Suffix Code	To Order These As Separate Units	
		Qty.	Catalog No.
1 N.O.	-10	1	100T-CB10
1 N.C.	-01	1	100T-CB01
2 N.O.	-20	2	100T-CB10
2 N.C.	-02	2	100T-CB01
1 N.O., 1 N.C.	-11	1	100T-CB11
2 N.O., 2 N.C.	-22	2	100T-CB11

Contact Ratings

NEMA Rating	Max. Volts	Amp. Rating		Va.		
		Make	Break	Continuous	Make	Break
Maximum A-C Contact Rating Per Pole, 50 or 60 Hertz						
A600	120	60	6	10	7200	720
	240	30	3			
	480	15	1.5			
	600	12	1.2			
Maximum D-C Contact Rating Per Pole						
P600	125	1.1	5			138
	250	0.55				138
	301-600	0.2				120

MILL DUTY PRODUCTS

Index



Description	Page Number
Limit Switches - Type	102HL E2, E3
	102TL..... E4, E5
	102RS E6
	102CHL..... E7
General Information.....	E8
Master Switch - Type	101FS E9, E10
	101SD..... E11
Palm Buttons - Type.....	100 RN E12

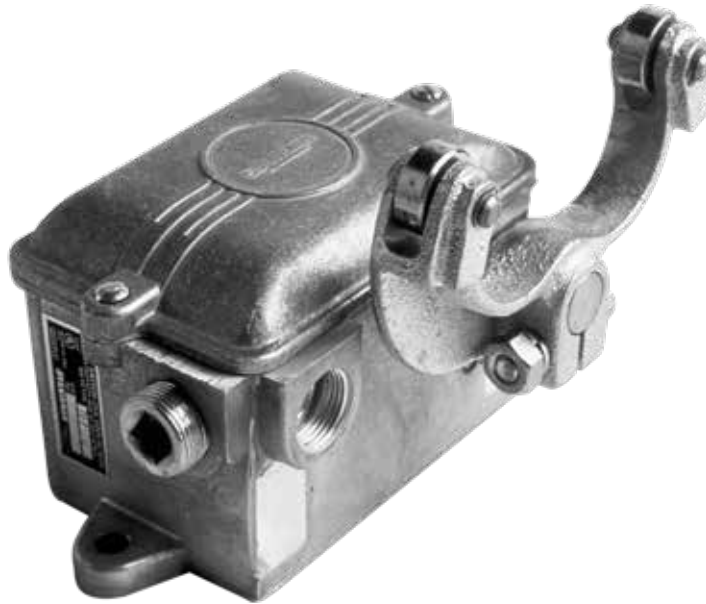

MILL DUTY PRODUCTS

Limit Switch



Right Hand Shown

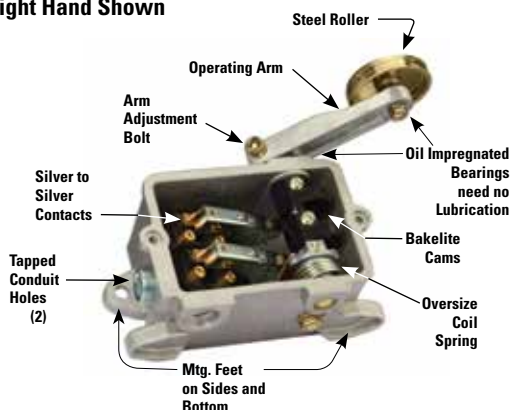

Application

Type 102HL and HLD Hatchway Limit Switches are designed as pilot circuit devices for all heavy duty applications to limit travel or set up function at predetermined positions. On Type HL single acting switches, the lever operates in one direction only; while on Type HLD double acting switches, it operates in two directions with a variety of contact sequences.

Features:

- Double Break removable Silver-to-Silver Contacts.
- Each contact may be independently changed from normally open to normally closed and vice versa without disassembly.
- Operating Arm on most models may be field changed to the other side by reversing the shaft.
- Oil impregnated bearings at contact finger pivot points.
- Oil impregnated shaft bearings need no lubrications.

Lever Travel is 50°
Each Direction

Type HL Single Acting Hatchway - Limit Switch

Right Hand²

Type	Contacts	Poles	Standard Enclosures	Dust-tight Enclosure	Watertight Enclosure
			Catalog No. ¹	Catalog No. ¹	Catalog No. ¹
HLA-1	NO or NC	1	A102-41252A-1	A102-231414A-1	A102-54634A-1
HLA-2	2 NO or 2 NC	2	A102-41251A-1	A102-231413A-1	A102-54635A-1
HLA-3	1 NO & 1 NC	2	A102-41251A-3	A102-231413A-3	A102-54635A-3
HLA-30	1 NO & 1 NC overlapping ⁴	2	A102-54268A-1	A102-273562A-1	A102-68866A-1
Left Hand²					
HLLA-1	NO or NC	1	A102-41252A-3	A102-231414A-3	A102-54634A-3
HLLA-2	2 NO or 2 NC	2	A102-41251A-4	A102-231413A-4	A102-54635A-4
HLLA-3	1 NO & 1 NC	2	A102-41251A-6	A102-231413A-6	A102-54635A-6
HLLA-30	1 NO & 1 NC overlapping ⁴	2	A102-54268A-2	A102-273562A-2	A102-68866A-2

Any 1 or 2 pole switch may be converted from right to left hand and vice versa using a screwdriver.

Note:

1. Includes operating lever and standard steel roller.
2. Type HLA-1, 2 & 44, HLLA-1 & 2 contacts are normally closed when shipped from the factory. To change to normally open, loosen cam and rotate 180°.
3. Any 1 or 2 pole switch may be converted from right to left hand and vice versa using a screwdriver.
4. Overlapping contacts are not convertible.

Limit Switch Electrical Ratings

25 Amp - 600V AC Maximum			
Heavy Pilot Duty 600V AC A600, 250V DC Maximum N300.			
Volts	Current - Amperes		
	Carry	Break	Inrush/ Make
110-120V AC	25	6.0	6.0
220-240V AC	25	3.0	3.0
440-480V AC	25	1.5	1.5
550-600V AC	25	1.2	1.2
115-125V DC	10	2.2	2.2
230-250V DC	10	1.1	1.1

Ordering Information

- Use complete catalog number when ordering. If modification is required, state in full detail on the order.

Modifications:

- Omit standard lever and roller.
- Phenolic composition roller, 2 1/2" dia., on standard lever in place of standard steel roller, A102-426105A
- Five-inch lever with standard steel roller, in place of standard lever and roller, A102-248096A
- Seven-inch dia., composition roller on 5" lever, in place of standard lever and roller, A102-75993A

Type HLD - Double Acting Hatchway - Limit Switch

Poles	Contacts Sequence ³		Standard Enclosure Catalog No.	Dust-tight Enclosure Catalog No.	Ship. Weight
	CCW	CW			
1			HLD-1	HLD-5	11 lbs.
2			HLD-2	HLD-6	
2			HLD-3	HLD-7	
2	as specified		HLD-4	HLD-8	
Poles	Contacts Sequence		Watertight Enclosure Catalog No.	Ship. Weight	12 lbs.
	CCW	CW			
1			HLD-9		
2			HLD-10		
2			HLD-11		
2	as specified		HLD-12		

Cams are included under JC80

HLA-1, 2, 3 & 30, HLLA-1, 2, 3 & 30,
Standard and Dust-tight Enclosures
12⁰ min. to operate std. 1 & 2 pole switches.
Switches with overlapping contacts require 22⁰ min.

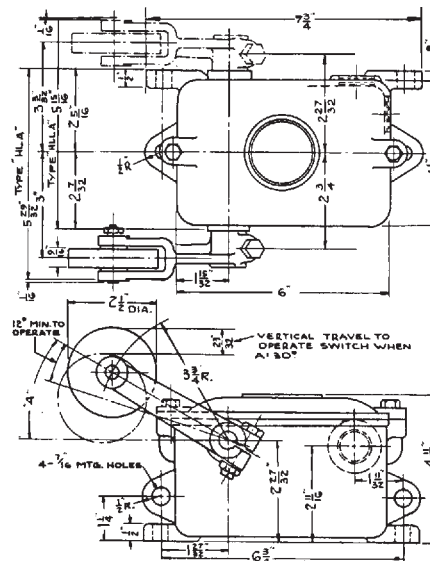

Contact Sequence

Cam No.	As Supplied		Converted To:	
	CCW	CW	CCW	CW
A102-277623				
A102-277624				
A102-277625				

Contact Closed Contact Open

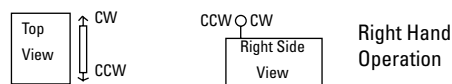

HLD-1, 2, 3 & 4 in Standard Enclosure HLD-5, 6, 7 & 8 in Dust-tight Enclosure

Spare Parts	JC 80
Movable Contact	A101-028965
Torsen Spring	A101-062988
1 Pole Base	A102-041256A
2 Pole Base	A102-041255A
Std. Arm & Roller	A102-302350A
JC32	
5" Lever with Steel Roller	A102-248096A
5" Lever with 7" Dia. Composition Roller	A102-075993A

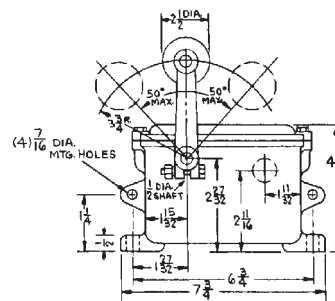
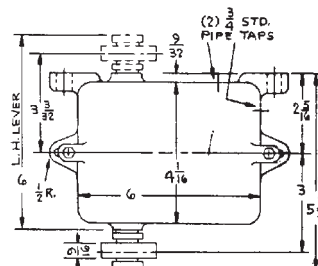

Limit Switch Electrical Ratings

25 Amp - 600V AC Maximum Heavy Pilot Duty 600V AC A600, 250V DC Maximum N300.			
Current - Amperes			
Volts	Carry	Break	Inrush/ Make
110-120V AC	25	6.0	6.0
220-240V AC	25	3.0	3.0
440-480V AC	25	1.5	1.5
550-600V AC	25	1.2	1.2
115-125V DC	10	2.2	2.2
230-250V DC	10	1.1	1.1

Ordering Information

- Use complete catalog number when ordering.
- Modifications on page G2. If modifications are required, state in full detail on the order.

Notes:

1. Includes operating lever and standard steel roller.
2. All contacts are NC when shipped from the factory. To change to NO, loosen cam and rotate 180°.
3. Any 1 or 2 pole switches may be converted from right to left hand and vice versa, using a screwdriver.

MILL DUTY PRODUCTS

Limit Switch



Application

Type 102TL Track Type Limit Switches are designed as pilot circuit devices for all heavy duty applications to limit travel or set up functions at predetermined positions.

Operation

The contacts of these switches make and break very quickly due to the snap action of the toggle type operating mechanism. The operating arm is secured to a hollow outer shaft that fits over the camshaft. When the arm is tripped, it turns the outer shaft which actuates the toggle mechanism. The toggle mechanism does not change position until the operating lever is past the midpoint of its travel; then it snaps over and turns the camshaft quickly. Since the cams are fastened rigidly to the camshaft, they in turn impart snap action opening and closing to the contacts. Force to operate switch is approximately 25 inch-pounds.

Angular Travel

Total angular travel of the arm from one tripped position to the other is 90°. However, the contacts are actuated when the arm moves 60°, the balance of the travel is to clear the arm so that the linear operator may pass over.



TLSF-11 or 22 with Straight Fork Lever

Features:

- Double Break removable Silver-to-Silver Contacts.
- Each contact may be independently changed from normally open to normally closed and vice versa without disassembly.
- Operating Arm adjustable on shaft.
- Oil impregnated bearings at contact finger pivot points.
- Cast weatherproof enclosure standard. Dust-tight and watertight enclosures are also available for all types.
- Contact wearing parts completely interchangeable with same parts in Type 101SD Master Switch, 101FS Foot Switch, and 102HL & CHL Limit Switch.

Available Levers:



Part # A102-054262
TLSF Straight
Fork Lever



Part # A102-054261
TLS Rod or
Chain Type Lever



A102-460805A-1
TLRS Straight Roller Lever



Part # 102-54260A
TLF Roller Fork
Lever

Left Hand Shown:

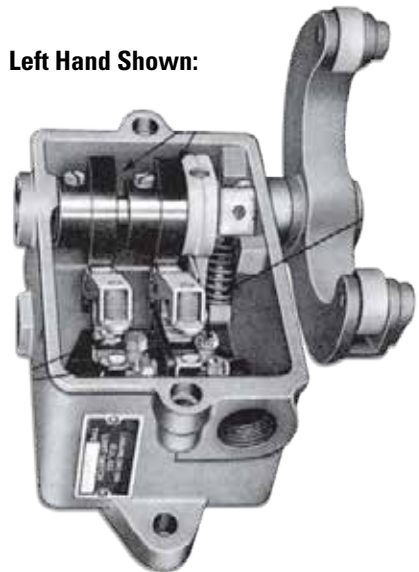

TLF-22, 2 Contacts, Cover Removed

Type TL Snap Action - Limit Switch

Type	Operating Lever	Contacts ²	Standard Enclosure Catalog No.	Dust-tight Enclosure Catalog No.	Watertight Enclosure Catalog No.
TLS-11	Rod or Chain	1	A102-80579A-1	A102-80579A-2	A102-80580A
TLS-22	Rod or Chain	2	A102-80581A-1	A102-80581A-2	A102-80582A
TLSR-11	Straight or Roller	1	A102-80591A-1	A102-80591A-2	A102-80592A
TLSR-22	Straight or Roller	2	A102-80593A-1	A102-80593A-2	A102-80594A
TLF-11	Roller Fork	1	A102-80575A-1	A102-80575A-2	A102-80576A
TLF-22	Roller Fork	2	A102-80577A-1	A102-80577A-2	A102-80578A
TLSF-11	Straight Fork	1	A102-80583A-1	A102-80583A-2	A102-80584A
TLSF-22	Straight Fork	2	A102-80585A-1	A102-80585A-2	A102-80586A

Note:

1. Includes limit switch complete with operating lever.
2. Contacts can be changed from open to close by rotating cam 180°.

Limit Switch Electrical Ratings

25 Amp - 600V AC Maximum Heavy Pilot Duty 600V AC A600, 250V DC Maximum N300.			
Volts	Current - Amperes		
	Carry	Break	Inrush/ Make
110-120V AC	25	6.0	6.0
220-240V AC	25	3.0	3.0
440-480V AC	25	1.5	1.5
550-600V AC	25	1.2	1.2
115-125V DC	10	2.2	2.2
230-250V DC	10	1.1	1.1

Ordering Information:

- Use complete catalog number when ordering.

Approximate Outline Dimensions

TLSR Straight Roller Lever

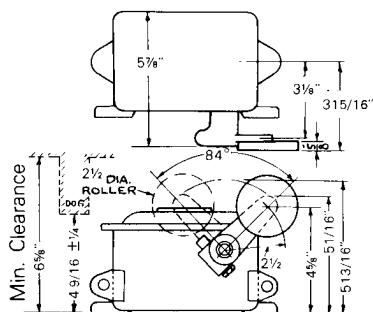

TLS Rod or Chain Type Lever

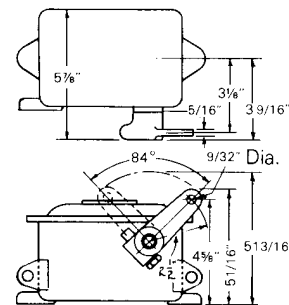

TLSF Straight Fork Lever

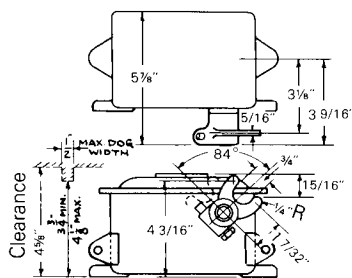

Enclosure Dimensions Only (Same for all types)

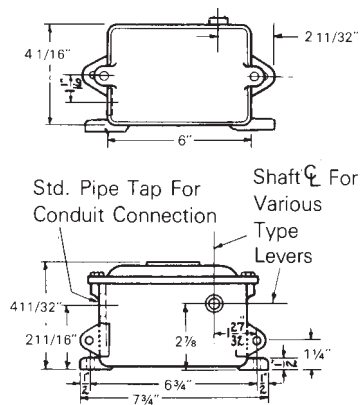

TLF Roller Fork Lever

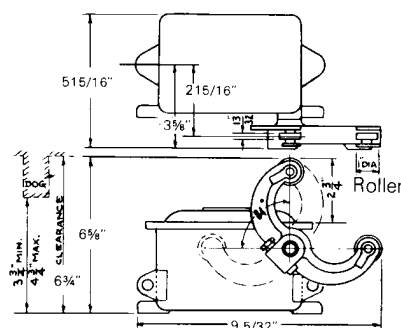

MILL DUTY PRODUCTS

Safety Switches

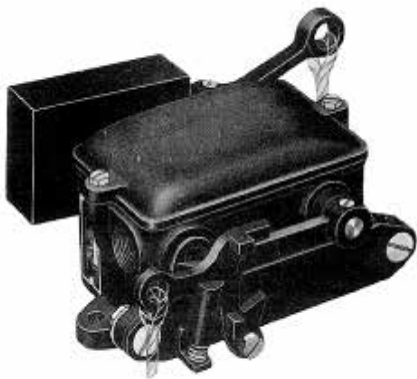

Application

Type 102RS Rubber Calender Safety Switch is a pilot circuit device used chiefly in the Rubber Industry as an emergency stop arrangement on Calenders, and similar motor driven machinery.

Features:

- Gravity Operated.
- Double break removable silver-to-silver contacts.
- Can be mounted horizontally or vertically.
- Oil impregnated shaft bearings need no lubrication.
- Contact wearing parts completely interchangeable with same parts in type 101SD Master Switches, type 101FS Foot Switches and type 102HL, CHL, TL Limit Switches.
- Dust-tight enclosure is standard.

Approximate Dimensions

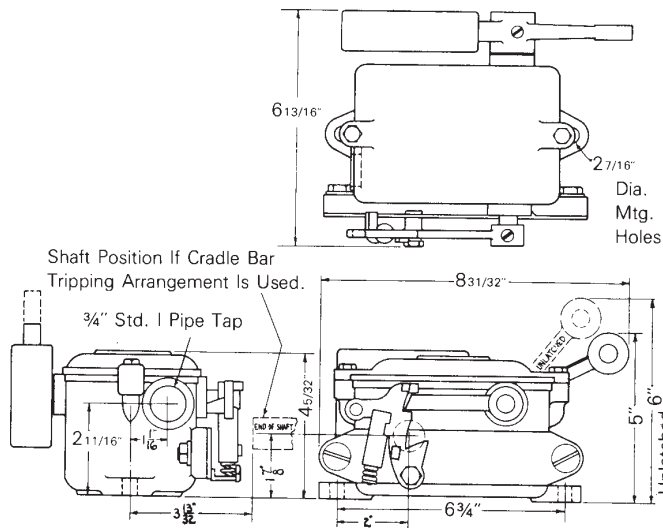

Limit Switch Electrical Ratings

25 Amp - 600V AC Maximum Heavy Pilot Duty 600V AC A600, 250V DC Maximum N300.			
Current - Amperes			
Volts	Carry	Break	Inrush/ Make
110-120V AC	25	6.0	6.0
220-240V AC	25	3.0	3.0
440-480V AC	25	1.5	1.5
550-600V AC	25	1.2	1.2
115-125V DC	10	2.2	2.2
230-250V DC	10	1.1	1.1

Rubber Calender

Type	Contacts	Poles	Dust-tight Enclosure Catalog No.
RS22	2 NC	2	A102-66750A

Note:

1. Includes limit switch complete with cable, cable weight and counterweight.

Ordering Information

- Use complete catalog number when ordering. If modification is required, state in full detail on the order.
Modifications:
- If cradle bar tripping arrangement is desired, add the following to the catalog number, "including part number A102-66747A tripping bar"



Application

The Type 102CHL pilot circuit limit switches are designed for mounting beneath the hoisting mechanism of electrically operated cranes to serve as upper limit safety stop switches. Such a safety device is necessary to prevent the hook from being raised into the hoisting mechanism where it would cause damage.

Enclosure - Standard die cast aluminum enclosures.

Dust-tight Enclosures - Dust-tight enclosures can be furnished at an additional charge for the dust seal gasket.

Watertight - Watertight enclosures are also available. The same heavy case is specially fitted with watertight bushings and seals to meet NEMA watertight tests.



- Cams A10252609
- 2 Pole Base A10241255A
- Weight 1 B102-80615
- Weight 2 A102-54265

Features:

- Toggle type snap action.
- Double break removable Silver-to-Silver Contacts.
- Contact wearing parts completely interchangeable with same parts in Type 101SD Master Switch, Type 101FS Foot Switches and Type 102HL and TL Limit Switches.
- Each contact may be independently changed from N.O. to N.C. and vice versa without disassembly, by turning cams on shaft 180°.
- Operating arm adjustable on shaft.
- Automatic reset when hook is lowered.
- Die cast aluminum enclosure standard.

E

Type 102CHL Crane Hook - Limit Switch

Type	Contacts	Poles	Standard Enclosure Catalog No.	Watertight Enclosure Catalog No.
CHL-22	2 NC	2	A102-80886A	A102-80887A

Limit Switch Electrical Ratings

25 Amp - 600V AC Maximum Heavy Pilot Duty 600V AC A600, 250V DC Maximum N300.				
Current - Amperes				
Volts	Carry	Break	Inrush/ Make	
110-120V AC	25	6.0	6.0	
220-240V AC	25	3.0	3.0	
440-480V AC	25	1.5	1.5	
550-600V AC	25	1.2	1.2	
115-125V DC	10	2.2	2.2	
230-250V DC	10	1.1	1.1	

Note:

1. Includes limit switch complete with cable, cable weight and counterweight. Approximate shipping weight is 45 lbs.

Ordering Information

Use complete catalog number.
If dust-tight enclosure is desired, use the same catalog number as for standard enclosure and specify "Dust-tight" on the order.

Approximate Dimensions

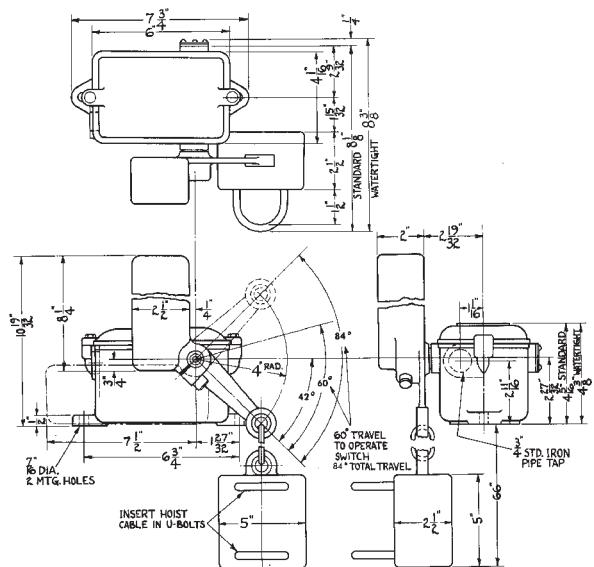

MILL DUTY PRODUCTS

General Information



Application

Type 101 FS Foot Operated Master Switches are used on applications requiring a rugged foot operated pilot circuit device.

Weatherproof enclosures are standard on all types.

Dust tight enclosures can be furnished at an additional charge for the dust seal gasket.

Enclosures

Two pole foot switches have cast aluminum enclosures.

Watertight enclosures are available for all types except Type FWLSA-22. The same heavy case is specially fitted with watertight bushings and seals to meet NEMA watertight tests.

Features

- Double Break removable Silver-to-Silver Contacts.
- Contact wearing parts completely interchangeable with the same parts in Type 101SD Master Switch, and Type 102HL, TL and CHL Limit Switch.
- Each contact may be independently changed from NO to NC and vice versa without disassembly.
- Oil impregnated bearings at contact finger pivot points.
- Oil impregnated shaft bearings need no lubrications
- Malleable iron operating pedal.
- Spring return standard.
- Cast Weatherproof enclosure standard.

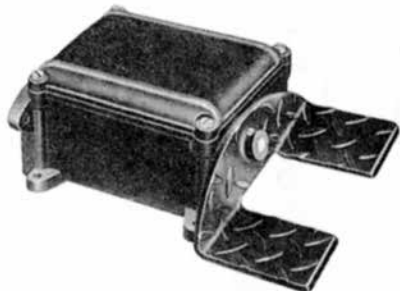

FRSA-22, 2 Pole 3 Position

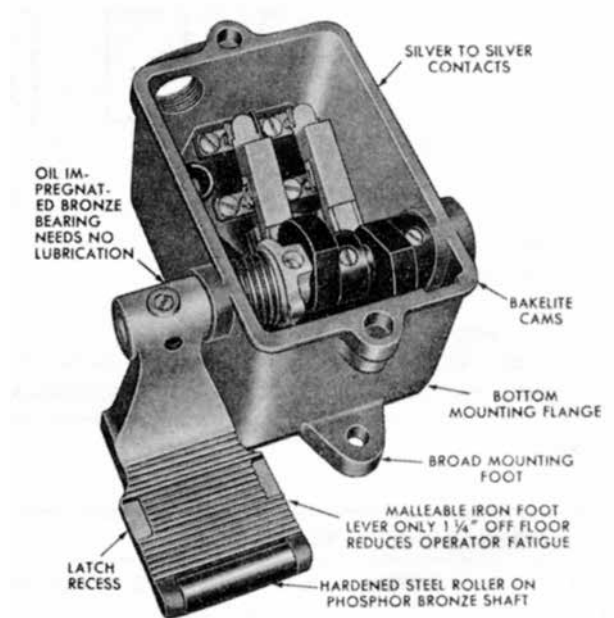

**FSA-22, 2 Pole
Horizontal Mounting, Left Hand, Open View**



Type 101FS - Foot Operated

Standard NEMA 1 Enclosure

Type	Poles	Contact Arrangement	Contact Symbol	Special Features	Mounting Arrangement	Pedal Arrangement	Catalog No.	Dim. Ref & Ship Weight
FSA-11	1	NO or NC	A or B	-----	Horizontal Only	R.H. or L.H.	A101-55171A-2	1 & 2
FSA-22	2	Both NO or NC	C or D	-----			A101-55172A-2	
FSA-33	2	1 NO & 1 NC	E	-----			A101-55172A-2	
FRSA-22	2	1 forward, 1 reverse and an off point	---	Double treadle foot pedal for reverse operating			A101-62266A	3

Type 101FS - Foot Operated

NEMA 4 Enclosure

Type	Poles	Contact Arrangement	Contact Symbol	Special Features	Mounting Arrangement	Pedal Arrangement	Catalog No.	Dim. Ref & Ship Weight
FSA-11	1	NO or NC	A or B	-----	Horizontal or Vertical	R.H. only	A101-60224A	1 & 2
FSA-22	2	Both NO or NC	C or D	-----			A101-60225A	
FSA-33	2	1 NO & 1 NC	E	-----			A101-60225A	
FRSA-22	2	1 forward, 1 reverse and an off point	---	Double treadle foot pedal for reverse operating	Horizontal Only	R.H. or L.H.	A101-62267A	3

Contact Symbols



A

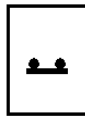

B

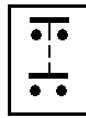

C

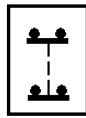

D

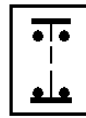

E

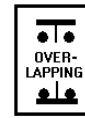

F

Note:

- Includes switch complete with operating pedal.
- Page G12 for Dimension reference and shipping weight.
- Overlapping Contacts:
Standard switches provide for only one contact closed at a time. If overlapping is required, one contact must close before the other contact opens.
Type FSA-330 switches have overlapping contacts. If the degree and/or point of overlap is not specified.

Ordering Information

- Use complete catalog number when ordering. If modifications are required, state in full detail on the order.

Note:

- Type 101FS does not meet the safety standards for press applications.

Modifications

For Dust tight use same catalog number as for a standard enclosure and specify "Dust tight" on order.
Floor plate.

MILL DUTY PRODUCTS

Master Switch

Dimensional Information

Reference No. 1 - Horizontal

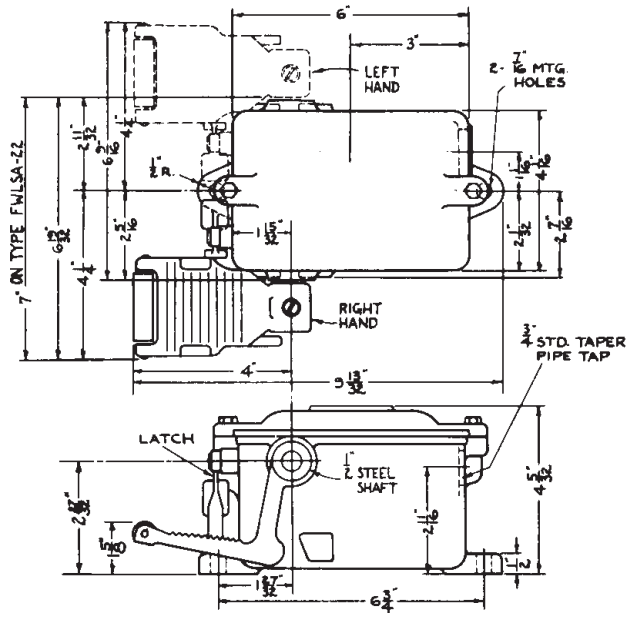

Reference No. 3- Double Treadle

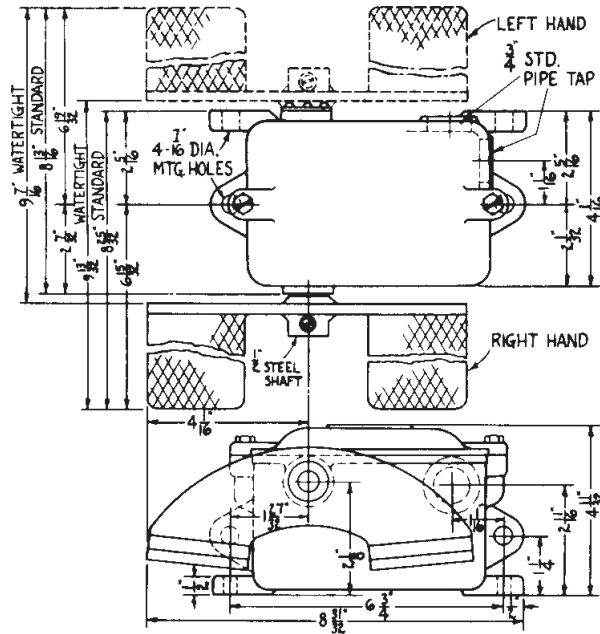

Shipping Weight (approx.)

Reference	Weight
No. 1	12 lbs.
No. 2	12 lbs.
No. 3	15 lbs.

E



Type 101SD Master Switches are designed as pilot circuit devices for frequent operation with minimum maintenance on heavy duty application in all industries. The type SD units are sturdy devices constructed for heavy duty service where few control circuits are required. Type SD Switches are made in two frame sizes:

Type SD-2 is a single point device, one point either side of the off point, and there are two isolated contacts which can be opened or closed in various combinations.

For the usual circuit arrangements refer to page G14.

Type SD Master Switches are supplied in watertight enclosures; panel mounted units have angle brackets for back of panel mounting. Spring return to the off point is available.

Master Switch, Enclosed Type SD-2 Two Circuit

Mill Master Jr. - Master Switch

Spring Return Operation

Type	Number of Operating Points	No. of Circuits	Reversing	Surface Mounting Catalog No.	Dim. Ref.
SD-2-S	1 (each direction)	2	yes	A101-88361A	A
	1 (one direction only)		no	A101-88365A	

Notes:

1. Includes master switch in watertight enclosure complete with operating handle.
 2. Includes master switch in watertight enclosure complete with metal pistol grip handle, steel mounting plate and standard anular name plate. Specify nameplate markings; standard nameplate provides one marking for each point of the switch.
- Advise detailed cam development for each switch. Refer to page G14 for diagram of standard cam development.

Ordering Information:

- Use complete catalog number when ordering.
- Dimensional reference on page G14

MILL DUTY PRODUCTS

100 Series



Mill Type Push Buttons (Heavy Duty) Type H Assembled



Type H Form RN
Unprotected



Type H Form RNG
With Guard Ring for
Palm Operation

Features:

- Heavy cast enclosure and mushroom operating head.
- Oil impregnated bushing.
- Heavy duty Type H push button element with double break silver-to-silver wipe action contacts.
- Large electrical clearance.
- Push button stop independent of contacts. All shock absorbed by the cast case.
- All parts removable and replaceable with a screwdriver.

E

Type H - Momentary Contact

			Form RN - Without Guard Ring	Form RNG - With Guard Ring
Name Plate ² Marking	Contacts Available	Contact Symbol	Catalog Number	Catalog Number
None	1 N.O. and 1 N.C.	1	1RN-1	1RNG-1
None	2 N.O. and 2 N.C.	4	1RN-2	1RNG-2

Note:

1. Includes assembled push button station complete with element.
2. With Name Plate at top, case may be turned so that Conduit Opening is at top or bottom.

Contact Blocks

1NO & 1NC	BA	JC80
2NO & 2NC	BB	Discount Scheule

Dimensions

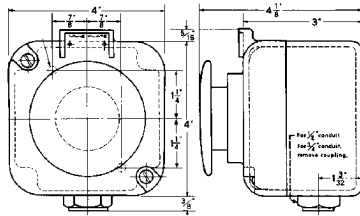

Form RN
Unprotected

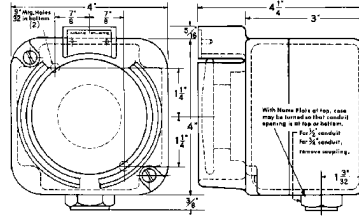

Form RNG
With Guard Ring for
Palm Operation

Volts	AC (50 or 60 Hz)		DC (Inductive)
	Normal	Inrush	Normal
110-120	6.0	60	2.2
220-240	3.0	30	1.1
440-480	1.5	15	----
550-600	1.2	12	0.4

Contact Symbols

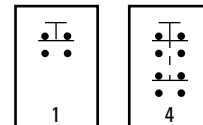

E

DC CONTROL

Index

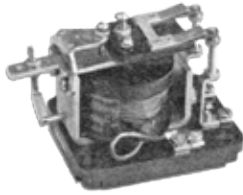

Description	Page Number
Index.....	F1
146 Field Loss Relay.....	F2
5 DP Series - General Information.....	F3
Contactors - 1, 2, 3 Pole.....	F4
Accessories.....	F5
Coils & Contact Kits.....	F6
Dimensions Data.....	F7
7400 Contactors.....	F8
7400 Accessories & Dimensions Data.....	F9
RHEOSTATS.....	F10

F

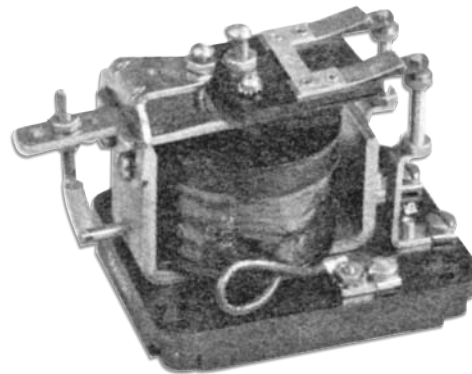
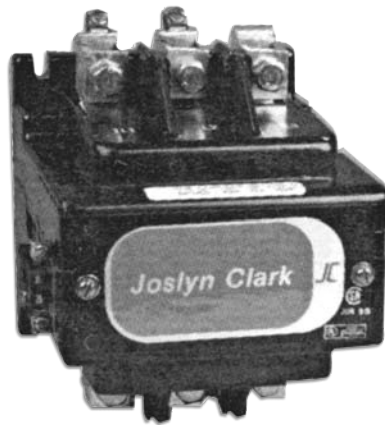

DC CONTROL

146 Field Loss Relay



Series 146 Relays provide excellent protection against over speeding on DC shunt or compound wound motors in the event of an open circuit in the field. The relay coil is connected in series with the shunt field while the re-lay motor contacts are in the motor control circuit. The relay coil is de-energized if the field opens and the relay contacts open to disconnect the motor from line. Where shunt or compound wound motors are operated at light loads or not rigidly connected to the load, field loss relays provide protection against motor and load damage from over speeding. The Series 146 Relay is a UL recognized component.

Coils are designed to carry maximum field current continuously. Relays are factory adjusted to pick-up at one tenth of the maximum field current amps. listed. Drop-out is approximately 62% of the pick-up value. Other pick-up values on special order.

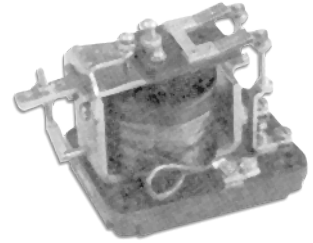

Field Loss Relays (DC) - 146 300V DC Max.

Max. Field Current Amps	Relay Pick-Up Amps	Relay Drop-Out Amps	Catalog No.	Max. Field Current Amps	Relay Pick-Up Amps	Relay Drop-Out Amps	Catalog No.
.25	.025	.0155	146-25	8.0	.800	.496	146-800
.5	.050	.031	146-50	9.0	.900	.559	146-900
1.0	.100	.062	146-100	10.5	1.050	.651	146-1050
1.5	.150	.093	146-150	12.0	1.200	.744	146-1200
2.0	.200	.124	146-200	13.5	1.350	.836	146-1350
2.5	.250	.155	146-250	15.0	1.500	.930	146-1500
3.0	.300	.186	146-300	22	2.200	1.320	146-2200
4.0	.400	.248	146-400	27	2.700	1.620	146-2700
5.0	.500	.310	146-500	35	3.500	2.100	146-3500
6.0	.600	.372	146-600	65	6.500	4.000	146-6500
7.0	.700	.434	146-700	80	8	4.96	146-8000

F

Engineering Data:

Dimensions -Approximate

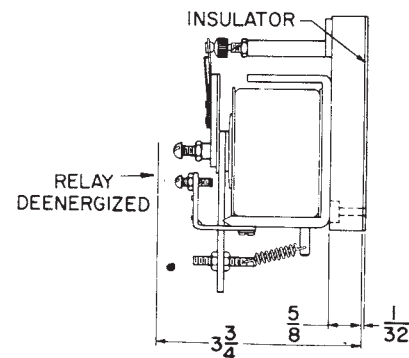
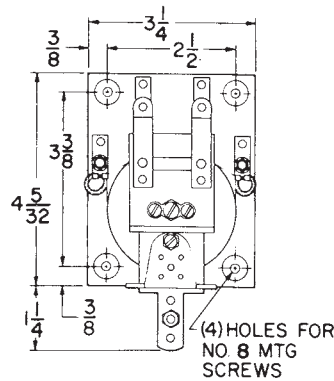
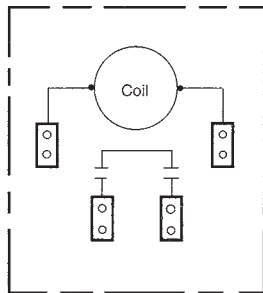

Ordering Information

- Use complete catalog number when ordering.
- Contact Rating: Single pole double break normally open contacts, rated at 0.7 amps., 250 V DC Max.



5DP Definite Purpose Contactors are designed for DC adjustable speed drive circuits using silicon controlled rectifier switching and other controls where a combination of normally open and normally closed power contacts are required. In all applications, reduced panel space for contactor mounting is made possible through a compact design and the built-in N.C. dynamic brake power contact feature.

In silicon controlled rectifier switching circuits, the SCR is normally phased back prior to contactor opening. Therefore, the N.O. contacts are not required to interrupt any appreciable current. Under abnormal conditions such as failure of the SCR or the control circuit, the contactor may be required to interrupt up to 200% current. The N.O. contacts are equipped with permanent magnet blowouts to meet this requirement.

The dynamic brake N.C. contact is required to insert the dynamic brake resistor and therefore must make up to 200% of rated current each time the contactor is de energized.

Jogging is accomplished at low voltage and current. Therefore, the dynamic brake contact is rated at 1/3 of rated voltage and dynamic brake current. The permanent magnet blowouts provide this interrupting ability.

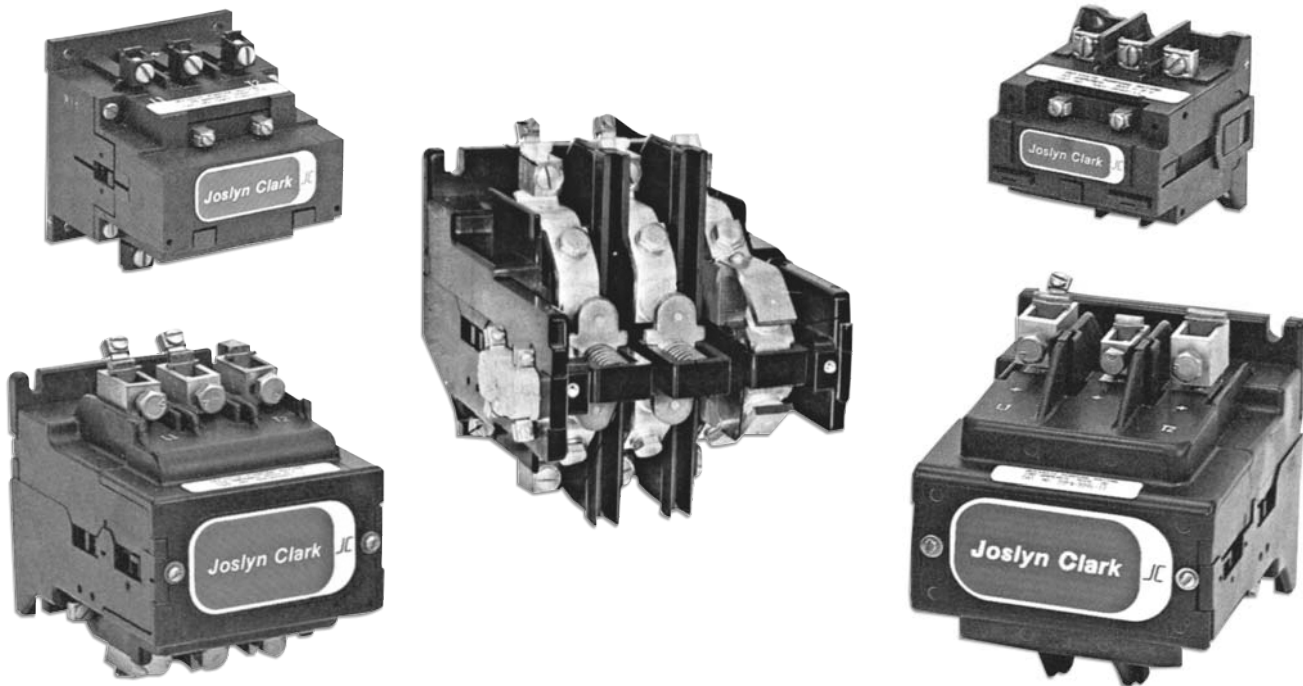

- 1. Normally Closed Double Break Power Contacts** - made of silver cadmium oxide furnish "anti-weld" protection under overload conditions. Generous size contacts are long lasting, and maintenance-free. All N.C. power contacts supplied with permanent magnet blowouts to lengthen contact life.
- 2. Normally Open Double Break Power Contacts** - incorporate the same design features as the normally closed power poles. Permanent magnet blowouts are also furnished on d.c. load applications.
- 3. Permanent Magnet Blowouts** - mounted to surround the power contacts, function to quickly quench the arc when breaking loads, thereby increasing contact life and assuring positive load circuit interruption. All normally closed poles are furnished with permanent magnet blowouts. Normally open poles can be supplied with or without blowouts as indicated in the circuit symbols shown on page J6.
- 4. Stainless Steel Springs** - maintain exact contact pressure and assure fast contact break (N.O.) and make (N.C.).
- 5. Molded Housing** - constructed of hot-molded, high impact, high arc resistant insulating material. This design totally encloses the contacts and operating magnet in separate compartments and functions to eliminate internal phase-to-phase short circuits.
- 6. Molded Coil** - is layer wound, designed for continuous duty service. Coil construction resists moisture; thermal and mechanical stress. Coil connections are made to pressure type terminals.
- 7. Free-Floating Armature-Magnet Frame** - provide quiet, low vibration, low friction operation. Precision ground pole faces achieve an absolute air gap which prevents "hanging-up". Magnet frame is sized for fast, powerful operation and self-seating extends operational life.
- 8. Auxiliary Contacts** - for 10/40 amp. contactors are available with either the front mounted snap action type with quick connect terminals or the side mounted type with pressure terminals. Contacts for larger sizes in standard or special make-before-break contact combinations feature either standard double break silver-to-silver contacts or low power gold alloy contacts.
- 9. Pressure Type Terminals** - accessible, up-front location permits modern straight-thru wiring. Terminals accept stripped, un-lugged wires.

F

DC CONTROL

5DP Contactors

SCR Drive Contactors - N.O. or N.C. Power Poles

Drive Contactors Preferred Style 500 VDC Max

Type & Rating	Poles			Open Type Catalog No.
	N.O.	N.C.	Fig.No.	
7001 40 amp.	0	1	7A	7001-5150- **
	0	2	9	7001-5230- **
	1	0	1	7001-6050- **
	2	0	3	7001-7030- **
	2	1	10	7001-7140- **
5DP7 75 amp.	0	1	7A	5DP7-5150- **
	0	2	9	5DP7-5230- **
	1	0	1	5DP7-6050- **
	2	0	3	5DP7-7030- **
	2	1	10	5DP7-7140- **
5DP3A 110 amp.	0	1	8	5DP3A4001- **
	0	2	9	5DP3A3071- **
	1	0	1	5DP3A4011- **
	2	0	3	5DP3A5021- **
	2	1	15	5DP3A5091- **
5DP4 180 amp.	0	1	8	5DP4-4001- **
	0	2	9	5DP4-3071- **
	1	0	1	5DP4-4011- **
	2	0	3	5DP4-5021- **
	2	1	15	5DP4-5091- **
5DP9 260 amp.	0	1	8	5DP9-4001- **
	0	2	9	5DP9-3071- **
	1	0	1	5DP9-4011- **
	2	0	3	5DP9-5021- **
	2	1	15	5DP9-5091- **
5DP5 360 amp.	0	1	8	5DP5-4001- **
	0	2	9	5DP5-3071- **
	1	0	1	5DP5-4011- **
	2	0	3	5DP5-5021- **
	2	1	15	5DP5-5091- **
5DP8 535 amp.	0	1	8	5DP8-4001- **
	0	2	9	5DP8-3071- **
	1	0	1	5DP8-4011- **
	2	0	3	5DP8-5021- **
	2	1	15	5DP8-5091- **

* Coil Table #1 Replace * with appropriate coil voltage digit.

60 Hz/Voltage	(*)	DC/Voltage	(*)
120	1	115	8
240	2	230	9

** Coil Table #2 Replace ** with appropriate coil voltage suffix

60 Hz/Voltage	Suffix	DC/Voltage	Suffix
120	11	12	72
208/240	21	24	82
208	90	48	32
240	21	120	12
480	41	240	22
600	51		

Drive Contactors - Old Style

For New Installations Use Preferred Style

Type & Rating	Poles			Open Type Catalog No.
	N.O.	N.C.	Fig.No.	
7000 10/40 amp.	0	1	7A	7000-5150- **
	2	0	3	7000-7030- **
	2	1	10	7000-7140- **
5DP1 30 amp.	0	1	8	5DP1-01()00 *
	0	2	9	5DP1-02()00 *
	1	0	1	5DP1-10()00 *
	1	1	5	5DP1-11()00 *
	2	0	2	5DP1-20()00 *
	2	1	6	5DP1-21()00 *
	2	0	3	5DP1-5021- **
5DP2 56 amp.	2	1	7	5DP1-5051- **
	0	1	8	5DP2-01()00 *
	0	2	9	5DP2-02()00 *
	1	0	1	5DP2-10()00 *
	1	1	5	5DP2-11()00 *
	2	0	2	5DP2-20()00 *
	2	1	6	5DP2-21()00 *
5DP3 110 amp.	2	0	3	5DP2-5021- **
	2	1	7	5DP2-5051- **
	0	1	8	5DP3-01()00 *
	0	2	9	5DP3-02()00 *
	1	0	1	5DP3-10()00 *
	1	1	5	5DP3-11()00 *
	2	0	2	5DP3-20()00 *
5DP4 180 amp.	2	1	6	5DP3-21()00 *
	2	0	3	5DP3-5021- **
	2	1	7	5DP3-5051- **
	0	1	8	5DP4-01()00 *
	0	2	9	5DP4-02()00 *
	1	0	1	5DP4-10()00 *
	1	1	5	5DP4-11()00 *
5DP9 260 amp.	2	0	2	5DP4-20()00 *
	2	1	6	5DP4-21()00 *
	2	1	7	5DP4-5051- **
	0	1	8	5DP9-01()00 *
	0	2	9	5DP9-02()00 *
	1	0	1	5DP9-10()00 *
	1	1	5	5DP9-11()00 *
5DP5 360 amp.	2	0	2	5DP9-20()00 *
	2	1	6	5DP9-21()00 *
	2	1	7	5DP9-5051- **
	0	1	8	5DP5-01()00 *
	0	2	9	5DP5-02()00 *
	1	0	1	5DP5-10()00 *
	1	1	5	5DP5-11()00 *
5DP8 535 amp.	2	0	2	5DP5-20()00 *
	2	1	6	5DP5-21()00 *
	2	1	7	5DP5-5051- **
	0	1	8	5DP8-01()00 *
	0	2	9	5DP8-02()00 *
	1	1	5	5DP8-11()00 *
	2	0	2	5DP8-20()00 *
535 amp.	2	1	6	5DP8-21()00 *
	2	1	7	5DP8-5051- **

The N.C. contact is short time rated for Dynamic Braking applications. Refer to table on page J7 for N.C. contact ratings.

F

Auxiliary Contact Blocks

Field Installation Kit	Kit No.
Front mtd. aux. 10/40 amp. Old Style & 40A.	
N.O. - N.C. right hand front mtg.	5999-3504
N.O. - N.C. left hand front mtg.	5999-3604
N.O. - N.C. for multiple front mtg.	5999-3704 ¹
For 10/40 amp. Old Style & 40-535 Amp.	
N.O.	5M63
N.C.	5M64
N.O. & N.C.	5M65
N.O. low power .	5M63L
N.C. low power.	5M64L
N.O. & N.C. low power.	5M65L
N.O. Standard & N.C. low power.	5M66
N.O. low power & N.C. standard.	5M65L0
N.C. late break.	5M64E
N.O. & N.C. late break.	5M68 ⁴
N.C. lower power late break.	5M64LE
N.O. & N.C. low power late break.	5M67 ⁴
N.O. low power & N.C. low power late break.	5M69 ⁴
Tandem mounting auxiliary. **	5M60DA

**** NOT for 10/40A or 40A**

Reversing Kits

Description	Kit No
Mechanical interlock 30-260 amps. contactors except 75 amp.	5999-4737
Mechanical interlock 75 amp. contactors	5999-4717
Mechanical interlock 360 & 535 amp.	5999-4757
Mechanical interlock for two 3-pole 700 amp. contactors	5999-4767
Mechanical interlock for two 700 amp. contactors (1 Pole & 2-Pole)	5M96
Reversing baseplate for 30, 56 & 75 amp.	5999-8569
Reversing baseplate for 110,180 & 260 amp. contactors	5999-8570
Reversing baseplate for 360 & 535 amp. contactors	5999-8571
Reversing baseplate for two 3-Pole 700 amp. contactors	5999-8572
Reversing baseplate for one 2-Pole 700 amp. & one 3-Pole 700 amp. contactors	5999-8573
For 2, 2 Pole 700 Amp	5999-8580

Notes:

- Kit includes one N.O. - N.C. auxiliary plus mounting hardware for installing 3rd and 4th auxiliary.
- Contains mounting hardware only. Order auxiliary separately.
- Without mounting bracket. Bracket required for mounting more than one extra auxiliary interlock.
- Not for use on 10/40, 40 & 75 Amp.
- If DC coil required then front Mtd Auxiliaries not available & contact blocks restricted to 2 & max. aux. contacts 4. 1 contact listed also used to economise coil when DC operated.

Auxiliary Contact Blocks contain 1 or 2 contacts depending on the type ordered, the table below lists max. # of contact blocks for each contactor rating.

Amps	Front Mtd		Side Mtd		Maximum Aux. Contacts	N.O.	N.C.	Amps	Front Mtd		Side Mtd		Maximum Aux. Contacts	N.O.	N.C.	
	LHS	RHS	LHS	RHS					LHS	RHS	LHS	RHS				
10/40 A	1 ⁵	1 ⁵	or	1	1	4=	2	2	180 A	0	0	2	2	8=	4	4
30 A	0	0		1	1	4=	2	2	260 A	0	0	2	2	8=	4	4
40 A	1 ⁵	1 ⁵	or	1	1	4=	2	2	360 A	0	0	2	2	8=	4	4
56 A	0	0		2	2	8=	4	4	535 A	0	0	2	2	8=	4	4
75 A	0	0		2	2	8=	4	4								
110 A	0	0		2	2	8=	4	4								

Terminal Polarity and Wiring Figures:

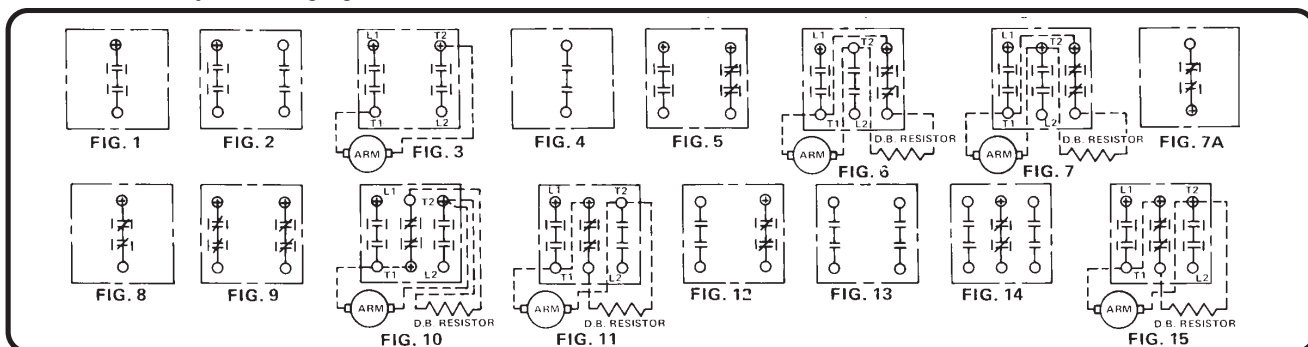

Symbols: \perp N.O. Contact $\perp/$ Contact with Blowout \diagup N.C. Contact \oplus Positive Polarity

Contacts without blowouts do not have any interrupting rating. Contactors with 2 N.O. contacts and blowouts will interrupt 200% current under abnormal conditions.

DC CONTROL

5DP Contactors

Contact Kits¹ - 5DP

Contactor Type	Rating	N.O. Contact Kit No.	N.C. Contact Kit No.
7000, 7001	10/40A 40A	5M19	5M20
5DP1	30A	5M55	5M57
5DP2	56A	5M52	5M58
5DP7	75A	5999-2521	5M48
5DP3A	110A	5M80A	5M58
5DP3	110A	5M53	5M49
5DP4	180A	5M54	5M49
5DP9	260A	5M56	5M49
5DP5	360A	5M-045	5999-2461
5DP8	535A	5999-2371	5999-2461
5DP6	700A	² 5999-2381	5999-2481

Coil Kits - 5DP (AC)

Rating	Volts 50/60Hz	V.A.-60Hz(Approx)		Kit No. ³
		Inrush	Sealed	
7000	120	120	28	5ML25
10/40A	208	120	28	5ML26
7001	240	120	28	5ML29
40A	480	120	28	5ML27
	600	120	28	5ML28
5DP1 30A	120	234	36	5ML21
5DP2 56A	240	264	41	5ML22
5DP3A	480	245	37	5ML23
110A	600	246	36.6	5ML24
5DP7 75A	120	290	48	5999-1801
	208	290	48	5999-1805
	240	290	48	5999-1802
	480	290	48	5999-1803
	600	290	48	5999-1804
5DP3 110A	120	672	62.4	5ML41
5DP4 180A	208/240	672	69.6	5ML42
5DP9 260A	480	672	67.2	5ML43
	600	683	72	5ML44
5DP5 360A	120	1725	151	5ML51
	208/240	1750	138	5ML52
5DP8 535A	480	1776	144	5ML53
	600	1782	145	5ML54

Auxiliary Contact Rating

AC Volts	10/40 Thru 100A Amperes	
	Continuous	Inrush
120	6	60
280	3	30
480	1.5	15
600	1.2	12

DC Power Pack Kits⁵ - AC Coils

Rating	Volts 60Hz	Kit No.
5DP6	120	5999-8061
700 amp.	240	5999-8062
	480	5999-8063

Contact Ratings

DC Contact Rating - Amperes											
Type & Rating	Poles	N.O. Contacts		N.C. Contacts (intermittent duty)		Type & Rating	Poles	N.O. Contacts		N.C. Contacts (intermittent duty)	
		240V	500V	Dynamic Brake Make Only- 500V Max.	Jogging Break Only 160V Max.			240V	500V	Dynamic Brake Make Only- 500V Max.	Jogging Break Only 160V Max.
7000	2	110	----	20	7	5DP4	1	----	10	315	105
10/40 amp.	2	110	110	80(240V)	27(80V)	180 amp.	2	40	----	----	----
7001	2	180	----	70	23	5DP9	1	40	40	387	135
40 amp.	2	180	180	----	----	260 amp.	2	----	----	----	----
5DP1	1	----	----	54	20	5DP5	1	30	30	720	240
30 amp.	2	260	260	----	----	360 amp.	2	30	30	----	----
5DP2	1	360	360	105	35	5DP8	1	56	56	1070	356
56 amp.	2	360	360	----	----	535 amp.	2	56	56	----	----
5DP7	2	----	----	150	50						
75 amp.		535	535								
5DP3	1	700	700	315	105						
5DP3A	2	700	700	----	----						
110 amp.											

Notes:

- Contact Kits for 1-pole include stationary contacts, movable contacts and contact spring except as noted for 700 amp. size.
- Assembled kit for 1-pole including yoke with movable contacts and springs; stationary contacts.
- For all pole combinations except 2-pole N.C.
- These coils are for exact replacement at operating voltage and frequency listed.
- Power pack assembly kit includes rectifier, economizing resistor and terminal block.
- Values measured at rectifier power pack input.
- It is necessary to phase back the SCR's so that contactor normally does not interrupt appreciable current. Contactors with blowouts and 2 N.O. contacts will interrupt 200% current under abnormal conditions.

Dimensions - Approximate
(Contactor base mounted vertically)

For side mounted auxiliary contact blocks add 1/2" per side to width dimension for all contactor sizes.

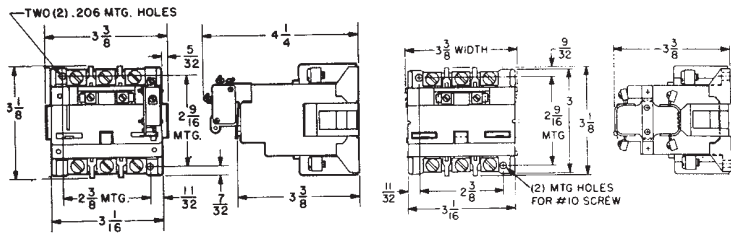

10/40 amp. contactor - 7000
40 amp. contactor - 7001
with front mounted auxiliary

10/40 amp. contactor - 7000
40 amp. contactor - 7001
with side mounted auxiliary

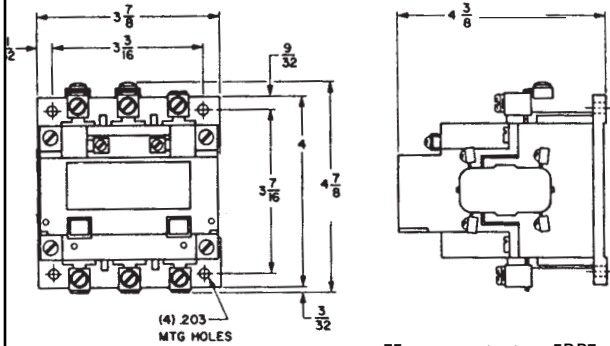

75 amp. contactor - 5DP7

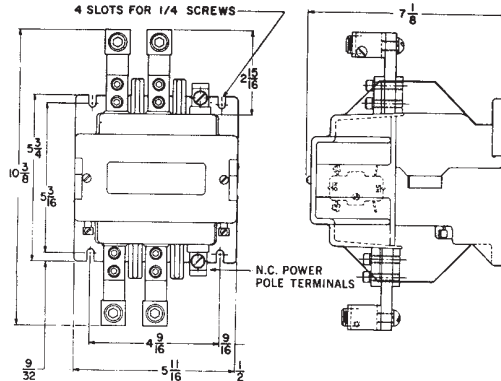

260 amp. contactor - 5DP9

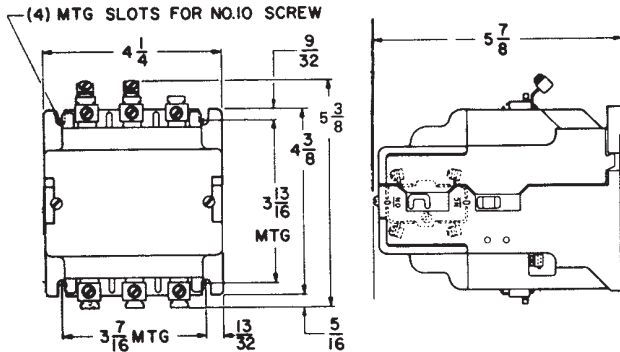

110 amp. contactor - 5DP3A
30 & 56 amp. contactor - 5DP1 & 5DP2

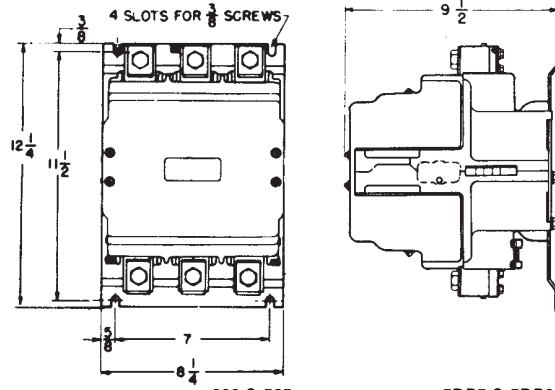

360 & 535 amp. contactor - 5DP5 & 5DP8

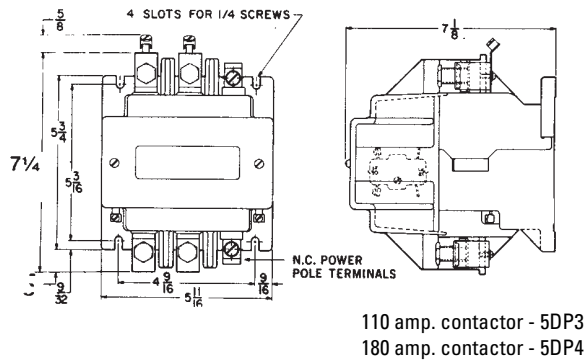

110 amp. contactor - 5DP3
180 amp. contactor - 5DP4

F

DC CONTROL - 7400

General Information

DC Contactors in sizes 1 Thru 5 are for use as main line, reversing or accelerating contactors in DC motor starters and controllers. Other applications include switching resistive heating and battery loads.

Description

All DC Contactors are solenoid operated for fast, constant, long-life performance. Generous size double break silver cadmium oxide contacts in combination with built-in permanent magnet blowouts assure long contact life and positive circuit interruption. Terminal location makes the contactors ideal for straight-through wiring and for wire channel layouts.

Accessible up-front pressure-type terminals are furnished as standard.

Auxiliary Contacts

All contactors can be furnished with N.O., N.C. or N.O. & N.C. auxiliary contact blocks. Each contactor can be supplied with a maximum of four auxiliary contact blocks. Kits are also available for field installation.

Operating Coils

Standard coils for DC operation are molded and equipped with pressure type terminals.

The DC coils are furnished with late break auxiliary and economizing resistors as standard.

AC coils can be furnished for applications requiring an AC control circuit.

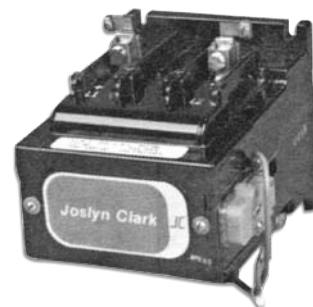

250 Volts DC Max

Size	8-Hour Rating in Amps.		Open Type DC Coil 1 Pole N.O.	Open Type DC Coil 2 Pole N.O.	Open Type DC Coil 2 Pole N.O. & 1 Pole N.C.
	Open	Enclosed	Catalog No. ²	Catalog No. ²	Catalog No. ²
1	25	22.5	74014010- *	7401-1020- *	7401-3050- *
2	50	45	74024010- *	7402-1020- *	7402-3050- *
3	100	90	-----	7403-1020- *	7403-3050- *
4	150	135	-----	7404-1020- *	7404-3050- *
5	300	270	7405-4010- *	7405-1020- *	7405-3050- *
Size	Open	Enclosed	1 Pole N.O. - AC Coil	2 Pole N.O. - AC Coil	2 Pole N.O. - 1 N.C. - AC Coil
1	25	22.5	7441-4010- *	7441-1020- *	7441-3050- *
2	50	45	7442-4010- *	7442-1020- *	7442-3050- *
3	100	90	-----	7443-1020- *	7443-3050- *
4	150	135	-----	7444-1020- *	7444-3050- *
5	300	270	7445-4010- *	7445-1020- *	7445-3050- *

Auxiliary Contact Ratings

DC Volts	Amperes Normal	AC Volts	Amperes	
			Normal	nrush
125	1.1	120	6.0	60
250	0.55	240	3.0	30
		480	1.5	15
		600	1.2	12

Notes:

1. On Sizes 3 & 4 only for single pole applications use two poles in series and for two pole applications use one pole in each line.
2. Contactor furnished without auxiliary contact. See Modifications & Accessories.

Ordering Information

Use complete catalog number. Replace the (*) with the suffix from the coil table.

Coil Table

AC 60Hz/Voltage	Suffix	DC Voltage	Suffix
120	11	24	82
208/240	21	48	32
480	41	120	12
600	51	240	22

RHEOSTATS



Vitrohm plate type 100-2000 WATTS 600 VOLT SERVICE

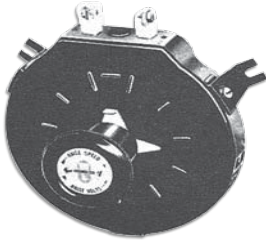

Fig. 1. Vitrohm pressed steel rheostat for front-of-board mounting.

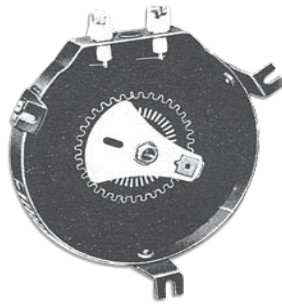

Fig. 2. 8" Vitrohm rheostat, Type S standard contacts, front-of-board mounting.



Fig. 3. 8" Vitrohm rheostat, Type M multi-step contacts, front-of-board mounting.

STANDARD SIZE RHEOSTATS - 6", 8", 13" TYPES S and M

APPLICATION

Vitrohm pressed steel rheostats furnish a simple, accurate and economical method of field control. They are universally applied for adjusting generator, alternator and exciter field currents to obtain variations in output voltage and for field control of adjustable speed D.C. and synchronous motors. Other typical applications include heater, furnace, battery charging and other controls.

4" RHEOSTATS-300 Volt Max. Service

APPLICATION

Vitrohm 4" rheostats for 300 volt max. service are specially designed for field and other control applications.

DANCER ROLL RHEOSTATS- 6, 8, 13 inch Types S and M

APPLICATION

Series 60DR rheostats are for dancer roll service on multi-motor drives where relative speeds between the motors must be maintained within specified limits. Typical applications of these field control rheostats include textile, paper, steel mills and others in the process machinery field.

**Consult Factory for all
Requirements**

MOTOR DRIVE ACCESSORIES-Type SMD

APPLICATION

Type SMD Accessories are for use with 8" or 13" rheostats where motor driven operation is required. Standard assemblies can be applied to drive up to four plates simultaneously. For larger 15 1/2" and 18" rheostats as well as the 13" size, a Type LMD large motor drive is available on order.

TO ORDER RHEOSTATS

- * Consult Factory for price and availability
- * If replacing and existing unit have the "K" number or serial number available.

FOR GENERATOR FIELD CONTROL SPECIFY:

1. Whether self-or separately-excited. If separately excited give voltage, field resistance (hot or cold) and minimum field current. If self-excited state maximum field current and field resistance (cold) under no load conditions, or peak generator voltage and field current at peak voltage and minimum generator voltage with field current at minimum voltage. For special control requirements supply saturation curve.
2. Open or enclosed
3. Type contacts
4. Type accessory.
5. Manual or motor drive
6. Optional or special

FOR OTHER APPLICATIONS SPECIFY:

1. Maximum and minimum current
2. Rheostat resistance.
3. Open or enclosed
4. Type contacts
5. Type accessory. If back-of-board mounting, state panel thickness
6. Manual or motor drive.
7. Optional or special features required.

F

RELAYS

Index

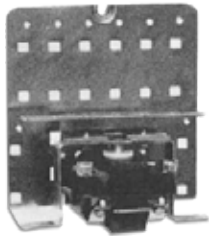
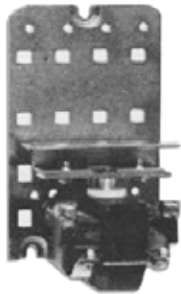
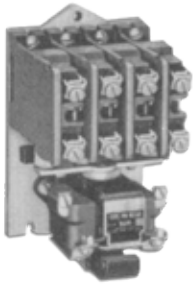

Description.....	Page Number
General Information.....	G2
<u>PM AC Relays</u>	
PM Convertible, PMA, PMF, AC Relays.....	G4
PM Latching, PML, PMAL, AC Relays.....	G5
Pole Arrangement, Diagrams, PM, PMA, PMF.....	G6
Dimensional Data, PM, PML, PMA, PMAL, PMF.....	G7
PMS, Slim Jim AC Relays.....	G8
PMT, AC Pneumatic Timing Relays.....	G10
PM Relay Parts and Modification Kits.....	G11
<u>PM DC Relays</u>	
PM Convertible DC Relays.....	G12
PML Latching DC Relays.....	G13
PMT DC Pneumatic Timing Relays.....	G14
Dimensional Data DC Relays.....	G16
Engineering Data.....	G17
Series 447 Relays.....	G18

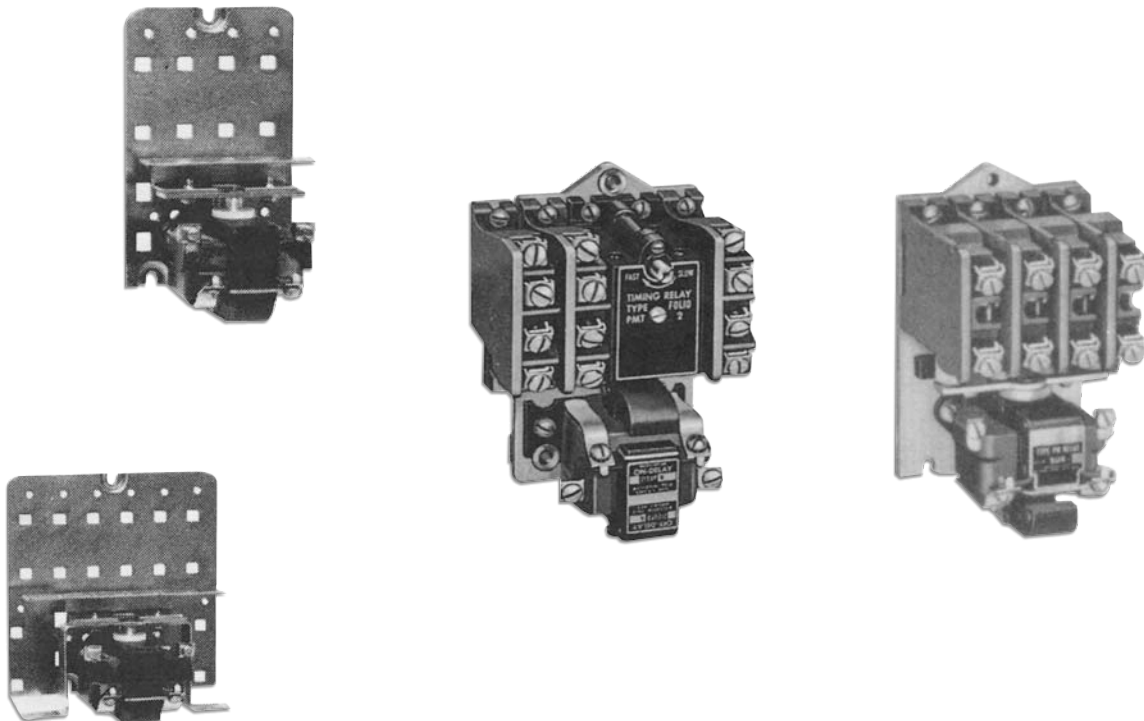

RELAYS - PM

General Information

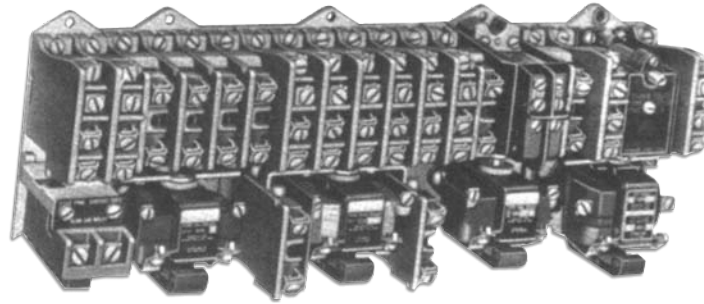

The Joslyn Clark PM Family of control relays provides flexibility, versatility and reliability. The exclusive design concept and rugged construction of the PM line offers many advantages for the designer and builder of today's complex control panels.

Features:

- Modular Construction -allows field addition, replacement or conversion of poles for unlimited flexibility.
- Uniformity of Design -simplifies engineering, installation and maintenance.
- Interchangeability of Parts - reduces inventory requirements. Flexibility of Application - provided by many modifications including noble metal, gold bonded, anti-weld and overlapping contacts.

G

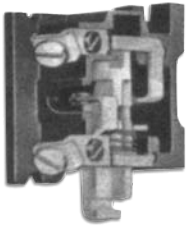

Convertible Poles contain one contact, either NO or NC and can be easily field converted from one to the other. Identified by WHITE operating rod.

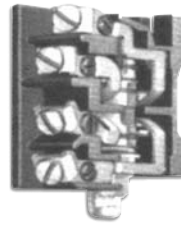

Universal Poles contain two independent isolated contacts, one NO and one NC. Identified by RED operating rod.

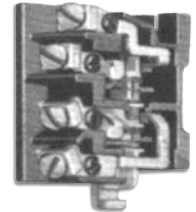

Duplex Poles contain two independent isolated contacts, both NO. Identified by GREEN operating rod.

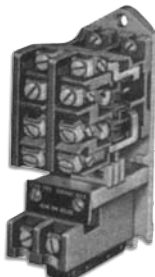

PMS Slim Jim Relays are 1 - 1/2" wide. They are the smallest members of the PM Family. Available with up to 4 contacts; they provide the reliability of heavy duty 600 Volt relays in the smallest possible space.

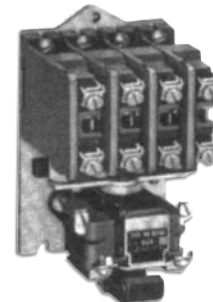

PM Convertible Pole Relays use white rod poles and are offered with up to 8 contacts in any combination of NO and NC contacts. Relays with up to 12 contacts using double deck bases can be supplied.

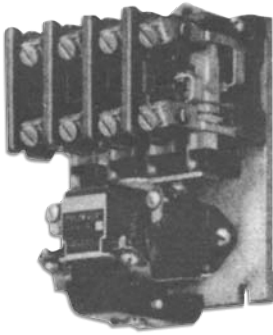

Type Relays, using universal poles have up to 12 contacts. Relays with up to 14 contacts are available, using some convertible poles. Type PMF Relays, combining several types of poles can have up to 14 contacts.

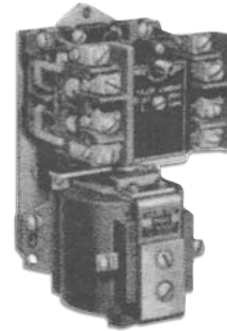
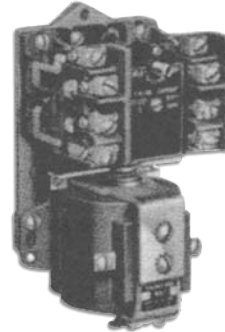

Type PMT Pneumatic Timing Relays, these relays are available for either "on-delay" operation (time delay after energization) or "off-delay" (time delay after de-energization). They may also be field converted from on to "off-delay" and vice versa, by merely inverting the operating magnet. Type PMT Time Delay relays are adjustable over a timing range from 0.2 seconds to 3 minutes with repetitive accuracy of $\pm 10\%$.

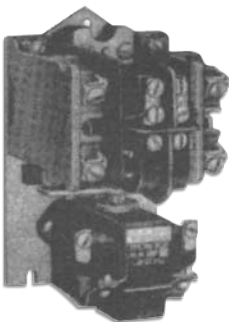

Latch Relays are available with either white rod convertible poles or red rod universal poles. The latching unit with continuous duty trip coil replaces the two pole modules directly above the relay magnet.

G

RELAYS - PM

AC Relays



Type PM Convertible, PMA Universal, PMF Duplex (Type 7305)

Total No. of Contacts ⁴	Normally Open Contacts	Normally Closed Contacts	Type PM Relays		Type PMA Relays		Type PMF Relays	
			Convertible Pole White Operating Rod		Universal Pole Red Operating Rod ¹		Duplex Pole Green Operating Rod ²	
			Catalog Number		Catalog Number		Catalog Number	
2	2	0	5U2	*	—	—	—	—
	1	1	5U2-1	*	—	—	—	—
	0	2	5U2-2	*	—	—	—	—
3	3	0	5U3	*	—	—	—	—
	2	1	5U3-1	*	—	—	—	—
	1	2	5U3-2	*	—	—	—	—
4	0	3	5U3-3	*	—	—	—	—
	4	0	5U4	*	—	—	5UFK4	*
	3	1	5U4-1	*	—	—	5UFK4-1	*
6	2	2	5U4-2	*	5UU2	*	—	—
	1	3	5U4-3	*	—	—	—	—
	0	4	5U4-4	*	—	—	—	—
	6	0	5U6	*	—	—	5UF6	*
	5	1	5U6-1	*	—	—	5UF6-1	*
8	4	2	5U6-2	*	—	—	5UF6-2	*
	3	3	5U6-3	*	5UU3	*	—	—
	2	4	5U6-4	*	—	—	—	—
	1	5	5U6-5	*	—	—	—	—
	0	6	5U6-6	*	—	—	—	—
	8	0	5U8	*	—	—	5UF8	*
10	7	1	5U8-1	*	—	—	5UF8-1	*
	6	2	5U8-2	*	—	—	5UF8-2	*
	5	3	5U8-3	*	—	—	5UF8-3	*
	4	4	5U8-4	*	5UU4	*	—	—
	3	5	5U8-5	*	—	—	—	—
	2	6	5U8-6	*	—	—	—	—
	1	7	5U8-7	*	—	—	—	—
	0	8	5U8-8	*	—	—	—	—
12	10	0	—	—	—	—	5UF10	*
	9	1	—	—	—	—	5UF10-1	*
	8	2	—	—	—	—	5UF10-2	*
	7	3	—	—	—	—	5UF10-3	*
14	12	0	—	—	—	—	5UF12	*
	11	1	—	—	—	—	5UF12-1	*
	10	2	—	—	—	—	5UF12-2	*
	9	3	—	—	—	—	5UF12-3	*
14	6	6	—	—	5UU6	*	—	—
	14	0	—	—	—	—	5UF14	*
	13	1	—	—	—	—	5UF14-1	*
	12	2	—	—	—	—	5UF14-2	*
	11	3	—	—	—	—	5UF14-3	*
	10	4	—	—	—	—	5UF14-4	*
	9	5	—	—	—	—	5UF14-5	*
	8	6	—	—	5UU86	*	—	—
7	7	—	—	5UU77	*	—	—	
6	8	—	—	5UU68	*	—	—	

¹ See notes 3,5 and 6 page G5 & G7 ² See note 2 page G5

Ordering Information

- Use complete catalog no. replace the (*) with suffix from coil Table, (Located on Page G5)



Type PM Latch Relays, PML Convertible, PMAL Universal (Type 7305)

Total No. of Contacts ⁴	Normally Open Contacts	Normally Closed Contacts	Type PML	Type PMAL
			Convertible Pole White Operating Rod	Universal Pole Red Operating Rod
			Catalog Number	Catalog Number
2	2	0	5UH2 *	—
	1	1	5UH2-1 *	—
	0	2	5UH2-2 *	—
3	3	0	5UH3 *	—
	2	1	5UH3-1 *	—
	1	2	5UH3-2 *	—
	0	3	5UH3-3 *	—
4	4	0	5UH4 *	—
	3	1	5UH4-1 *	—
	2	2	5UH4-2 *	5UUH2 *
	1	3	5UH4-3 *	—
	0	4	5UH4-4 *	—
6	6	0	5UH6 *	—
	5	1	5UH6-1 *	—
	4	2	5UH6-2 *	—
	3	3	5UH6-3 *	5UUH3 *
	2	4	5UH6-4 *	—
	1	5	5UH6-5 *	—
	0	6	5UH6-6 *	—
8	4	4	—	5UUH4 *
10	6	4	—	5UUH64 *
	5	5	—	5UUH55 *
	4	6	—	5UUH46 *

Latch Relays

The latch unit occupies the space of two poles directly above the magnet, and provides a means of holding the relay in the energized position after the coil of the main operating magnet is

de-energized. Momentarily energizing the continuous duty coil of the latch unit allows the relay to return to the normal, de-energized position.

Relay Enclosure P6E-01

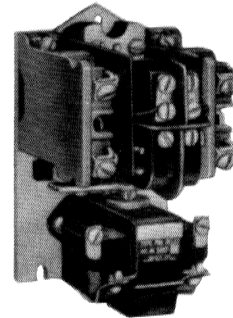

5U4B - * 4 pole base only
5U8B - * 8 pole base only

G

- 1 Maximum of 8 contacts only.
- 2 PMF relays with N.C. contacts have universal red rod & duplex green rod poles. Maximum of 8 contacts only on 25 hz.
- 3 Includes open type relay complete with operating coil. Latching relays include latch unit with continuous duty trip coil.
- 4 Overlapping contacts are available. Specify when ordering.
- 5 For Dimensions, refer to page G7 For modification Kits, refer to page G11.
- 6 Additional relays with alternate pole configurations available.

Ordering Information

- Use complete catalog number. Replace the (*) with suffix coil table.
- Ex. 4 Pole Relay with 120V, 60Hz. coil; 5UH4-76.
- Latch Relays are supplied with main coil and latch coil of the same voltage. For variations, consult factory.

* Suffix Coil Table

Volts	Hertz	
	60	50
24	—96	—95
110-120	—76	—75
220-240	—26	—25
380	—36	—35
440-480	—46	—45
550-600	—56	—55

RELAYS - PM

AC Relays



Contact Arrangement Type PM Convertible Pole Relays

Numbers in pole locations indicate the sequence in which normally closed poles are mounted when required.

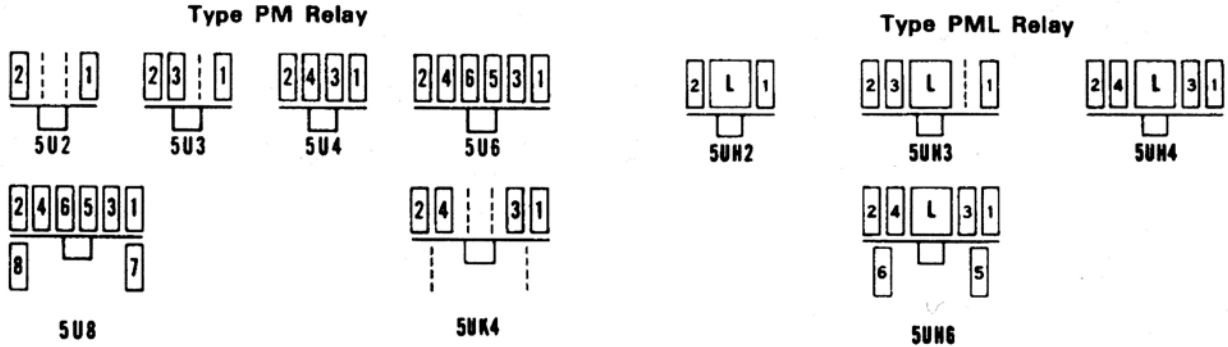

Type PMA Universal Pole Relays

Numbers in pole locations indicate the sequence in which normally closed convertible poles are mounted when required.

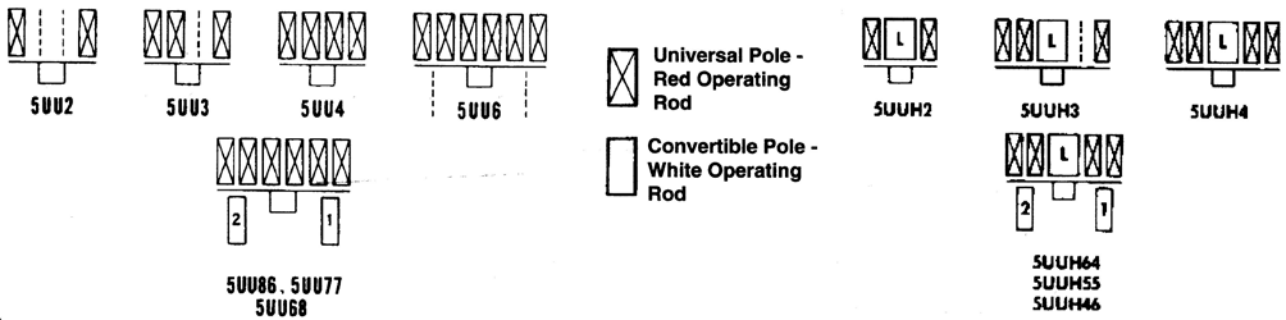

Type PMF Duplex Pole Relays

Numbers in pole locations indicate the sequence in which Universal poles are mounted when required.

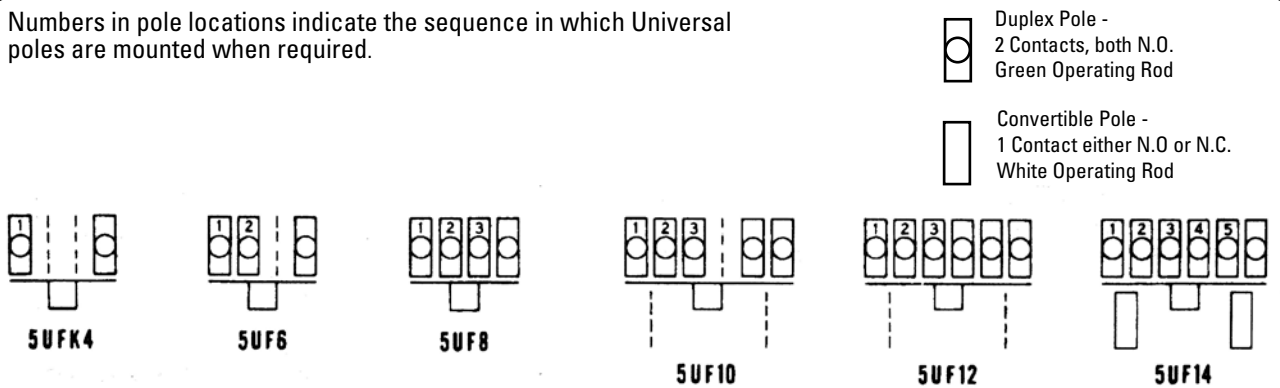

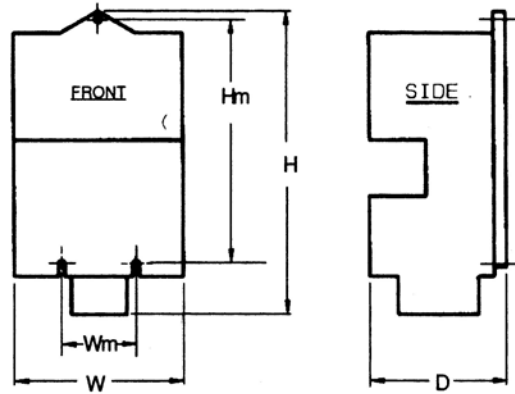

All relays require a minimum of 7/8" clearance below magnet for coil change 1/8" horizontal spacing between relay is recommended.

Mounting Holes for #10 Screws

Relay Type	Open Relay Cat. Number	H	W	D	Hm	Wm
PM	5U2, 5U3, 5U4	5 ⁵ / ₁₆	3	3	4 ¹ / ₂	2
	5U6	5 ⁷ / ₁₆	4 ¹ / ₂	3	4 ¹ / ₂	2
	5U8, 5UK4	5 ⁷ / ₁₆	4 ¹ / ₂	3	4 ¹ / ₂	2
PML	5UH2	5 ⁵ / ₁₆	3	3 ⁵ / ₈	4 ¹ / ₂	2
	5UH3, 5UH4	5 ⁵ / ₁₆	4 ¹ / ₂	3 ⁵ / ₈	4 ¹ / ₂	2
	5UH6	5 ⁷ / ₁₆	4 ¹ / ₂	3 ⁵ / ₈	4 ¹ / ₂	2
PMA	5UU2, 5UU3, 5UU4	5 ⁵ / ₁₆	3	3 ¹ / ₄	4 ¹ / ₂	2
PMF	5UFK4, 5UF6	5 ⁵ / ₁₆	4 ¹ / ₂	3 ¹ / ₄	4 ¹ / ₂	2
	5UU6, FUF10, 5UF12	5 ⁵ / ₁₆	4 ¹ / ₂	3 ¹ / ₄	4 ¹ / ₂	2
	5UU86, 5UU77, 5UU68, 5UF14	5 ⁷ / ₁₆	4 ¹ / ₂	3 ¹ / ₄	4 ¹ / ₂	2
PMAL	5UUH2	5 ⁵ / ₁₆	3	3 ⁵ / ₈	4 ¹ / ₂	2
	5UUH3, 5UUH4	5 ⁵ / ₁₆	4 ¹ / ₂	3 ⁵ / ₈	4 ¹ / ₂	2
	5UUH64, 5UUH55, 5UUH46	5 ⁷ / ₁₆	4 ¹ / ₂	3 ⁵ / ₈	4 ¹ / ₂	2
	713UP; 1-2 Pole	5 ¹ / ₂	3	3 ³ / ₈	4 ¹ / ₂	2
	713UP; 3 Pole	5 ¹ / ₂	3 ³ / ₄	3 ³ / ₈	4 ¹ / ₂	2
	713UP; 4 Pole	5 ¹ / ₂	4 ¹ / ₂	3 ³ / ₈	4 ¹ / ₂	2
	713UPD; 1-2 Pole	5 ⁵ / ₈	3	3 ³ / ₈	4 ¹ / ₂	2
	713UPD; 3 Pole	5 ⁵ / ₈	3 ³ / ₄	3 ³ / ₈	4 ¹ / ₂	2
	713UPD; 4 Pole	5 ⁵ / ₈	4 ¹ / ₂	3 ³ / ₈	4 ¹ / ₂	2

RELAYS - PMS

AC Relays



AC Relays - Slim Jim Type PMS - Bulletin 7305

Pole ‡ Arrangement	Contacts		Description	Rod Color	Open Type Cat. No.
	N.O.	N.C.			
	1	0	1 Convertible Pole	White	5SW *
	2	0	2 Convertible Poles	White	5SWW *
	2	0	1 Duplex Pole	Green	5SG *
	4	0	2 Duplex Poles	Green	5SGG *
	1	1	1 Universal Pole	Red	5SR *
	2	2	2 Universal Poles	Red	5SRR *
	3	1	1 Universal Pole and 1 Duplex Pole	Red Green	5SRG *

Relay Enclosure P6E-01

G

Approximate Dimensions In Inches

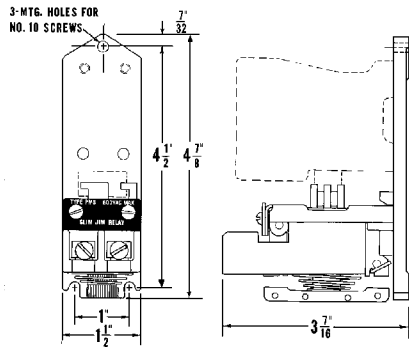

‡ Pole Symbols

- Represents one Convertible Pole, which includes one normally open contact.
- Represents one Duplex Pole, which includes two normally open contacts.
- Represents one Universal Pole, which includes two contacts, one normally open and one normally closed.
- Represents one space where a Convertible, Duplex or Universal Pole may be added.

Ordering Information

- Use complete catalog number. Replace the (*) with the suffix from Coil Table.
- Example: Cat. No. 5SRR-76 (110-120 Volt, 60 Hertz).
- Engineering Data
- Modification page K9

* Coil Table

60Hz Voltage	Suffix	60 Hz Voltage	Suffix
24 Separate Control	-96	200-240	-26
120 Separate Control	-76	440-480	-46
		550-600	-56



Pole Assemblies

Contacts		Rod	Pole	Kit
N.O.	N.C.	Color	Description	Cat. No.
1	0	White	Convertible Pole	KPM-1A
0	1	White	Convertible Pole	KPM-2A
1	1	Red	Universal Pole	KPMA-1
2	0	Green	Duplex Pole	KPMF-1
1	0	White	Convertible Pole — Anti-Weld Contacts	KPM-31A
0	1	White	Convertible Pole — Anti-Weld Contacts	KPM-32A
1	1	Orange	Overlap Contact	KPMA-21
1	1	Red	Universal Pole — Anti-Weld Contacts	KPMA-2
2	0	Green	Duplex Pole — Anti-Weld Contacts	KPMF-2
1	1	Orange	Overlap. Anti- Weld Contacts	KPMA-22



KPMA - 1



KPMF - 1



KPM - 1A

Relay Bases Only

Coil		Base
Voltage	Hertz	Catalog Number
24	60	5S-96
110-120	60	5S-76
110	50	5S-75
220-240	60	5S-26
220	50	5S-25
380	50	5S-46
440-480	60	5S-46
550-600	60	5S-56

Ordering Information

Coil Data

Coil Table

• Use complete catalog number.	Inrush volt-amperes (at 60 hertz) <u>61</u>	60Hz Voltage	Suffix	60 Hz Voltage	Suffix
	Holding volt-amperes (at 60 hertz) <u>16</u>	24 Separate Control	-96	200-240	-26
		120 Separate Control	-76	440-480	-46
				550-600	-56

G

RELAYS - PMT

Delay Relays



AC Pneumatic Time Delay Relays - Type PMT Bulletin 7313

Timing Range Adjustable From 0.2 Second To 3 Minutes - Accuracy + 10%

Oper'ng Mode	No. of Univ. Poles	Contacts				Universal Pole ⁶ Arrangement	Open Type Relays
		Time Delay		Instan.Aux.			Catalog No
		N.O.	N.C.	N.O.	N.C.		
On Delay Off Delay	1	1	1	None	None		713UP *
		1	1	None	None		713UPD *
On Delay Off Delay	2	1	1	1	1		713UPA *
		1	1	1	1		713UPDA *
On Delay Off Delay	2	2	2	None	None		713UPE *
		2	2	None	None		713UPDE *
On Delay Off Delay	3	1	1	2	2		713UPB *
		1	1	2	2		713UPDB *
On Delay Off Delay	3	2	2	1	1		713UPF *
		2	2	1	1		713UPDF *
On Delay Off Delay	4	1	1	3	3		713UPC *
		1	1	3	3		713UPDC *
On Delay Off Delay	4	2	2	2	2		713UPG *
		2	2	2	2		713UPDG *

Notes

1. Includes open type relay complete with timing head and operating coil. To complete Cat. No., add coil suffix.
2. On Delay - Timed interval occurs between energization of the coil and actuation of timed contact.
3. Off Delay - Timed interval occurs between de-energization of the coil and actuation of timed contact.
4. Each universal pole consists of two independent isolated contacts suitable for 600 volts at opposite polarity.
5. Relays may be converted in the field from On Delay to Off Delay and vice versa, using only a screwdriver. When this conversion is made, normally open contacts become normally closed contacts and vice versa.
6. On sketches showing universal pole arrangements: Letters T indicate locations of time delay poles. Letters I indicate locations of instantaneous poles. Dotted lines indicated locations where universal poles may be added. Class A relays may have two timed poles maximum.

Ordering Information

- Use complete catalog number. Replace the (*) with the suffix from Coil Table.
- Example: Cat. No. 713UPA (110-120 Volt, 60 Hertz).
- Overlapping contacts are available in the same contact block.

- Engineering Data
- Modification page K11

Coil Table

60Hz Voltage	Suffix	60 Hz Voltage	Suffix
24 Separate Control	-96	200-240	-26
120 Separate Control	-76	440-480	-46
		550-600	-56

Modification Kits for Type PM Family - Discount Schedule JC55

Description	Catalog Number
Kits for BUL. 7305 Type PM Convertible Pole Relays	
Pole Kits (All are convertible)	
N.O. Non-Overlap Contacts, Closed Top	KPM-1A
N.C. Non-Overlap Contacts, Closed Top	KPM-2A
N.O. Non-Overlap Contacts, Open Top	KPM-3A
N.C. Non-Overlap Contacts, Open Top	KPM-4A
N.O. Non-Overlap Anti-Weld Contacts, Closed Top	KPM-31A
N.C. Non-Overlap Anti-Weld Contacts, Closed Top	KPM-32A
N.O. Non-Overlap Anti-Weld Contacts, Open Top	KPM-33A
N.C. Non-Overlap Anti-Weld Contacts, Open Top	KPM-34A
N.O. Non-Overlap Gold Bonded Contacts, Closed Top	KPM-41
N.C. Non-Overlap Gold Bonded Contacts, Closed Top	KPM-42
N.O. Non-Overlap Gold Bonded Contacts, Open Top	KPM-43
N.C. Non-Overlap Gold Bonded Contacts, Open Top	KPM-44
Kits for BUL. 7305 Type PMA Universal Pole Relays	
Pole Kit -	
N.O. & N.C. Non-Overlap Contacts, Closed Top	KPMA-1
N.O. & N.C. Non-Overlap Anti-Weld Contacts, Closed Top	KPMA-2
N.O. & N.C. Overlapping Contacts, Closed Top	KPMA-21
N.O. & N.C. Overlapping Anti-Weld Contacts, Closed Top	KPMA-22
Kits for BUL. 7305 Type PMF Duplex-Pole Relays	
Pole Kits -	
2 N.O. Non-Overlap Contacts, Closed Top	KPMF-1
2 N.O. Non-Overlap Anti-Weld Contacts, Closed Top	KPMF-2
Kit for BUL. 7305 Type PML or PMAL Latch Relays	
Latch Kit, with coil - Specify trip coil voltage suffix: - 76 (110-120v 60hz). —26 (220-240v 60hz), - 46 (440-480v 60hz). Specify other voltages	KPMH-12
Kits for BUL. 7313 Type PMT Timing Relays	
Contact Operating Link for R.H. Timed Pole	KPMT-1
Contact Operating Link for Instantaneous Pole	KPMT-2
Contact Mounting Bracket and Arm Assembly (R.H.)	KPMT-3
Contact Mounting Bracket and Arm Assembly (L.H.)	KPMT-4



KPM - 1A



KPMF - 1



KPMA - 1

Renewal Parts Kits - Discount Schedule JC80

Renewal Parts Kits for BUL. 7305 Type PM Convertible Pole Relays	Cat. No.
Contact Arm, Short (4 Pole) with screws	KPM-7
Contact Arm, Long (6 Pole) with screws	KPM-8
Assembled Magnet and Rod (Straight-End Bracket) A-c Relays	KPM-9
Assembled Magnet and Rod (Hooked-End Bracket) A-c Relays	KPM-10
Assembled Magnet and Core. 2,3 & 4 Pole D-c Relays (Includes Rod, Bracket & Contact Arm)	KPM-16
Assembled Magnet and Core, 6 & 8 Pole D-c Relays (Includes Rod, Bracket & Contact Arm)	KPM-17
Renewal Parts for BUL. 7313 Type PMT Timing Relays	
Assembled Magnet and Rod (Folio 2 Relays)	KPMT-10
Timing Head (without dial) (Folio 2 Relays)	KPMT-12

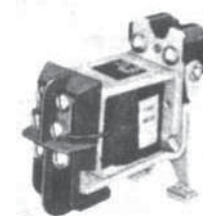

Kit KPMH - 12



Kit KPMT - 12

G

RELAYS - PMS

DC Relays



DC Relays - Type PM Bulletin 7304

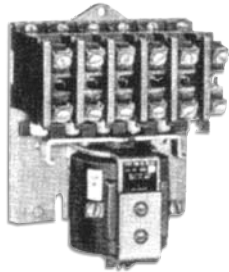

General Description

Bulletin 7304, Type PM, D-C Convertible Pole Relays feature many of the same time-proven advantages offered by the highly successful Bulletin 7305 Type PM A-C Relay. For example, normally open poles are quickly and easily convertible to normally closed and vice versa. Each pole is contained in its own molded housing mounted by a single screw. Thus, each pole may be removed, installed or replaced individually without disturbing the others. The large double-break contacts are made of fine silver alloy, and are rated for both inductive and resistive loads. The contacts are designed with wipe action to assure maximum reliability.

For long trouble-free relay life, the D-C coil on Bulletin 7304 Relays is molded with tough epoxy resin to keep out dirt and moisture, and to prevent physical damage. The magnet used is a vertical lift type with no springs that require adjustment. It is designed with pull-in characteristics that keep magnet slam to a minimum. Extra wide pressure terminals are front mounted for ready accessibility. As many as three lugs for No. 12 wire can be connected to each terminal.

Bulletin 7304 Relays are available in 2,3,4,6 and 8-pole arrangements.

Total Number Of Poles	Contact Arrangement	Poles ² Normally Open	Normally Closed	Open Type Catalog Number
2		2	0	4U2 *
		1	1	4U2-1 *
		0	2	4U2-2 *
3		3	0	4U3 *
		2	1	4U3-1 *
		1	2	4U3-2 *
		0	3	4U3-3 *
4		4	0	4U4 *
		3	1	4U4-1 *
		2	2	4U4-2 *
		1	3	4U4-3 *
		0	4	4U4-4 *
6		6	0	4U6 *
		5	1	4U6-1 *
		4	2	4U6-2 *
		3	3	4U6-3 *
		2	4	4U6-4 *
		1	5	4U6-5 *
		0	6	4U6-6 *
8		8	0	4U8 *
		7	1	4U8-1 *
		6	2	4U8-2 *
		5	3	4U8-3 *
		4	4	4U8-4 *
		3	5	4U8-5 *
		2	6	4U8-6 *

Contact Ratings - 10 Amps Continuous

D-C Applications			
Volts	Ampere Interrupting Rating		
	Resistive Load		
	Non-Inductive		Inductive Load
	N.O.	N.C.	N.O. or N.C.
64 or less	10	10	2.2
120	8	6	1.1
240	2	1	.55
A-C Applications			
Volts	Make	Break	
110	60	6	
220	30	3	
440	15	1.5	
550	12	1.2	

Notes:

- Numbers in pole locations shown in sketches indicate the sequence in which normally closed poles are mounted when required.
- Normally open contacts may be changed in the field to normally closed and vice versa, using only a screw driver.

Spare Parts Page G11

Ordering Information

- Use complete catalog number. Replace the (*) with the suffix from Coil Table.
- Overlapping contacts are available in the same contact block.
- Enclosures supplied separately
- For 32 & 64 volt coils, use coil suffix 32 or 64.
- 10 Piece Min

* Coil Table DC Voltage

DC Voltage	Suffix	DC Voltage	Suffix
12	012	95	095
24	024	120	120
48	048	240	240



DC Latch Relays - Type PML Bulletin 7305

Bulletin 7305, Type PML, D-C Latch Relays are identical in design, construction and dimension to the Type PML, A-C Convertible Pole Latch Relays except they incorporate the use of one "universal" pole on the relay to permit continuous application of voltage to the relay "Close" coil and latch "Trip" coil. The schematic diagram below illustrates how this is accomplished.

Up to 8 convertible poles in any combination of N.O. and N.C. contact arrangement are available for circuit use. The contracts can be readily converted in the field from N.O. to N.C. operation, and vice versa. The latch mechanism is the same rugged unit used on Type PML-A-C latch relays.

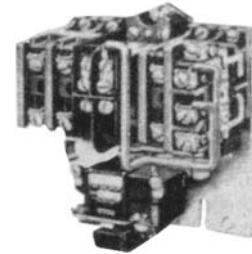

Contact Ratings - 10 Amps Continuous

D-C Applications			
Volts	Amperes Interrupting Rating		
	Resistive Load		
	Non-Inductive		Inductive Load
	N.O.	N.C.	N.O. or N.C.
64 or less	10	10	2.2
120	8	6	1.1
240	2	1	.55
A-C Applications			
Volts	Make	Break	
110	60	6	
220	30	3	
440	15	1.5	
550	12	1.2	

Typical Circuit



Universal Pole (Kit Catalog No. KPMA-21). Normally closed contact connected in series with relay "Close" coil. Normally open contact connected in series with relay "Trip" coil as shown below. Permits continuous application of voltage to the coil circuits.

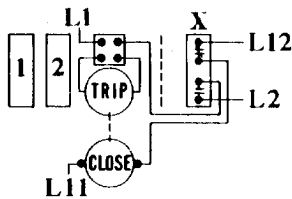

Total Number Of Poles	Contact Arrangement	Poles ²		Open Type Catalog Number
		Normally Open	Normally Closed	
2		2	0	5UHD2 *
		1	1	5UHD2-1 *
		0	2	5UHD2-2 *
3		3	0	5UHD3 *
		2	1	5UHD3-1 *
		1	2	5UHD3-2 *
		0	3	5UHD3-3 *
4		4	0	5UHD4 *
		3	1	5UHD4-1 *
		2	2	5UHD4-2 *
		1	3	5UHD4-3 *
		0	4	5UHD4-4 *
6		6	0	5UHD6 *
		5	1	5UHD6-1 *
		4	2	5UHD6-2 *
		3	3	5UHD6-3 *
		2	4	5UHD6-4 *
		1	5	5UHD6-5 *
8		8	0	5UHD8 *
		7	1	5UHD8-1 *
		6	2	5UHD8-2 *
		5	3	5UHD8-3 *
		4	4	5UHD8-4 *
		3	5	5UHD8-5 *

Notes:

- Numbers in pole locations shown in sketches indicate the sequence in which normally closed poles are mounted when required.
 - Normally open contacts may be changed in the field to normally closed and vice versa, using only a screw driver.
- ± Relay pole cannot be located here.

Ordering Information

- Use complete catalog number. Replace the (*) with the suffix from Coil Table.
- Overlapping contacts are available in the same contact block.
- Enclosures supplied separately

Coil Table DC Voltage

DC Voltage	Suffix
120	120
240	240

RELAYS - PMT

DC Time Delay Relays



DC Pneumatic Time Delay Relays - Type PMT Bulletin 7314 (.2 seconds to 3minutes)

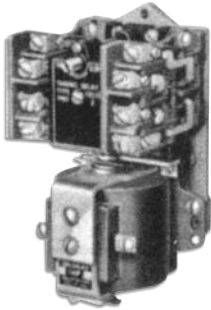

"On-Delay"
Operation

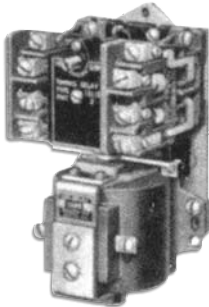

"Off-Delay"
Operation

Bulletin 7314 D-C Time Delay Relays are identical in construction to the Bulletin 7313 Timing Relays except for the use of a conventional 2 lead operating coil rather than a tapped (3-lead) coil. They feature the same accurate piston-type timing head as used on all other timing relays in the PM family.

Universal poles, with two electrically isolated contacts per pole-one normally open and one normally closed-are also used. These timing relays are available for either On Delay or Off Delay operation in three basic models: (1) with timed pole; (2) with one timed and one instantaneous pole or (3) with two timed poles.

Timing range adjustable from 0.2 seconds to 3 minutes Accuracy + 10%

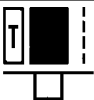
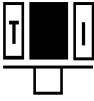
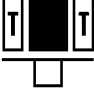
Type Oper'n Plus Delay	No. of Univ. Poles	Contacts				Universal Pole Arrangement	Open Type Relays Without Dial Catalog No
		Time Delay		Instan.Aux.			
		N.O.	N.C.	N.O.	N.C.		
On Delay	1	1	1			 714UP 714UPD	
Off Delay		1	1				
On Delay	2	1	1	1	1	 714UPA 714UPDA	
Off Delay		1	1	1	1		
On Delay	2	2	2			 714UPE 714UPDE	
Off Delay		2	2				

Coil Burden 17.2 watts

Notes:

- 1 On Delay - timed interval occurs between energization of the coil and actuation of timed contact.
Off Delay - timed interval occurs between de-energization of the coil and actuation of timed contact. Field conversion of relays from On Delay to Off Delay operation, or vice-versa, is not recommended because a special technique is required.
- 2 Each universal pole consists of 1 N.O. & 1 N.C. independent isolated contacts suitable for 600 volts at opposite polarity, a-c or d-c.
- 3 Letter T on relay sketches indicated location of time delay poles. Letter I on relay sketches indicates location of instantaneous poles. Dotted lines indicate where universal poles may be added.

Spare Parts Page G11

Contact Ratings - 10 Amps Continuous

D-C Applications			
Volts	Amperes Interrupting Rating Resistive Load		
	Non-Inductive N.O.	N.C.	Inductive Load N.O. or N.C.
64 or less	10	10	2.2
120	8	6	1.1
240	2	1	.55
A-C Applications			
Volts	Make	Break	
110	60	6	
220	30	3	
440	15	1.5	
550	12	1.2	

Ordering Information

- Use complete catalog number. Replace the (*) with the suffix from Coil Table.
- Overlapping contacts are available in the same contact block.
- For timer with dial, specify "with dial".

Coil Table DC Voltage

DC Voltage	Suffix
120	120
240	240

DC Pneumatic Time Delay Relays - Type PMT Bulletin 7313 (.2 seconds to 3minutes)

Bulletin 7313, Type PMT, D-C Time Delay Relays are identical in construction and size to the A-C timing relays except they incorporate a tapped (3-lead) d-c operating coil and, hence, require the use of one N.C. contact in a universal pole to economize the coil (see sketches below. However, the N.O. contact in that pole remains available for customer use. Timing relays with conventional 2-lead coils can also be supplied. Refer to Bulletin 7314-PMT.

Timing Range Adjustable From 0.2 Second to 3 Minutes - Accuracy $\pm 10\%$

Oper'ng Mode	No. of Univ. Poles	Contacts				Universal Pole Arrangement	Open Type Relays	
		Time Delay		Instan.Aux.			Without Dial	
		N.O.	N.C.	N.O.	N.C.		Catalog No	
On Delay	1	1	1	None	None		713UP-DC *	
Off Delay		1	1	None	None		713UPD-DC *	
On Delay	2	1	1	1	1		713UPA-DC *	
Off Delay		1	1	1	1		713UPDA-DC *	
On Delay	2	2	2	None	None		713UPE-DC *	
Off Delay		2	2	None	None		713UPDE-DC *	
On Delay	3	1	1	2	2		713UPB-DC *	
Off Delay		1	1	2	2		713UPDB-DC *	
On Delay	3	2	2	1	1		713UPF-DC *	
Off Delay		2	2	1	1		713UPDF-DC *	

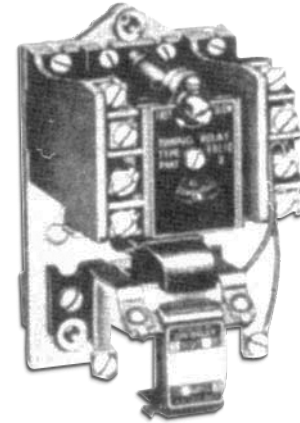

Coil Burden: Inrush 350 Watts
Sealed 5 Watts

G

Contact Ratings - 10 Amps Continuous

D-C Applications			
Volts	Amperes Interrupting Rating Resistive Load		
	Non-Inductive		Inductive Load
	N.O.	N.C.	N.O. or N.C.
64 or less	10	10	2.2
120	8	6	1.1
240	2	1	.55
A-C Applications			
Volts	Make	Break	
110	60	6	
220	30	3	
440	15	1.5	
550	12	1.2	

Functioning of Economizing Interlock Pole On D-C Relays

X - Economizing electrical interlock (used in coil circuit) is one contact of standard universal pole. Typical connection of three terminal coil is shown.

Spare Parts Page G11

"ON-DELAY"

(Time Delay after energization)

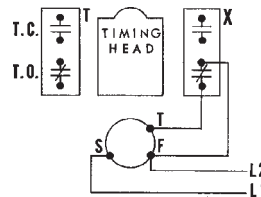

"OFF-DELAY"

(Time Delay after deenergization)

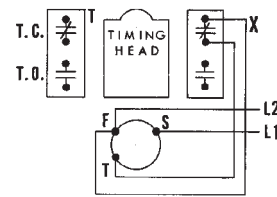

Ordering Information

- Use complete catalog number. Replace the (*) with the suffix from Coil Table.
- Overlapping contacts are available in the same contact block.
- For timer with dial, specify "with dial".

Coil Table DC Voltage

DC Voltage	Suffix
120	120
240	240

RELAYS - PM

Engineering Data

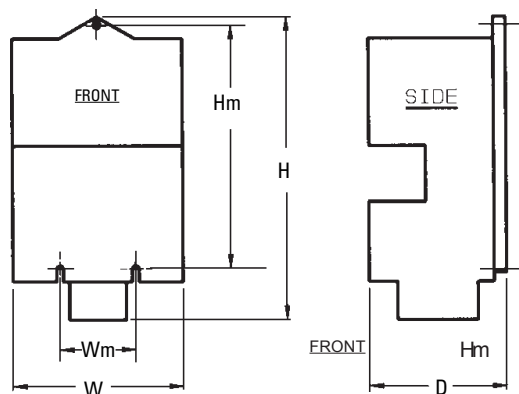

DC Contact Rating - P600

Volts	Amperes		Volt Amperes ²		Continuous
	Make	Break	Make	Break	Amperes
125	1.1	1.1	138	138	5
250	0.55	0.55	138	138	5
600	0.20	0.20	138 ²	138 ²	5

² 300 Volts or Less

All relays require a minimum of 7/8 in. clearance below magnet for coil change.

A horizontal space of 1/8 in. between relays is recommended.

Mounting Holes For #10 Screws

Relay Type	Open Relay Cat. Number	H	W	D	Hm	Wm
PM-DC	4U2,4U3,4U4	6 1/8	3	3 1/4	4 1/2	2
	4U6,4U8	6 1/8	4 1/2	3 1/4	4 1/2	2
PML-DC	5UHD2	5 5/16	3	3 5/8	4 1/2	2
	5UHD3, 5UHD4	5 5/16	4 1/2	3 5/8	4 1/2	2
PMT-DC	714UP	6 1/8	3	3 1/8	4 1/2	2 1/2
	713UP-DC 1,2-Pole	5 1/2	3	3 3/8	4 1/2	2
	713UP-DC 3 Pole	5 1/2	3 1/4	3 3/8	4 1/2	2
	713UP-DC 4 Pole	5 1/2	4 1/2	3 3/8	4 1/2	2

G

Standard catalog listed AC relays ordered will have the proper coils as determined by the voltage and frequency suffix to the catalog number. Changing the circuit arrangement on a relay also changes the mechanical load on the magnet and may require a change of operating coil to assure proper operation. The information on this page will enable you to select the correct operating coil for any circuit arrangement required. Voltage-ampere requirements are provided to help in designing your panels.

To select the proper operating coil for all basic and latch relays **except** the Slim Jim, first determine the mechanical load on the magnet simply by totalling the load represented by the individual components operated by the magnet, using the mechanical load factors shown below. Select the proper coil from Table 1. When selecting the proper coil for Slim Jim Relays and Time Delay Relays, it is not necessary to determine the mechanical load factor.

As shown in Table 1, one coil for each voltage and frequency will operate all pole combinations.

Mechanical Load Factors:	
Convertible Pole - Normally Open	10
Convertible Pole - Normally Closed	12
Double Contact Pole - Universal or Duplex	36
Latch Mechanism	20
Example:	
A relay with 1 N.O. and 9 N.C. convertible poles and a latch mechanism will have a mechanical load factor as follows:	
1 N.O. Convertible Pole	10
9 N.C. Convertible Poles	108
Accumulation Factor ¹	30
1 Latch Mechanism	20
Total Mechanical Load Factor	168

¹ For relays with 9 or more normally closed convertible poles, an accumulation factor of 30 must be added to the total mechanical load factor for the relay

For Example:
Table 1 indicates that the proper coil number for 110 volts, 60 hertz application is TB113-61, since the load factor of 168 falls within the Mechanical Load Range of 145 to 192.



Coil Application Tables - Type PM Relay Family **Table 1**

AC Volts	Hertz	Basic And Latch Relays				Slim Jim Relays All Pole Combinations	Trip Coil on Latch Relays, All Pole Combinations	Time Delay Relays
		Mechanical Load Range (Does Not Apply To Slim Jim Relays)						Class A All Pole Combinations
		20-72	73-144	145-192	193-240			
Coil Catalog Numbers - Bulletin 7303 & 7305 PM & PML								
24	60	TB113-36	TB113-37	TB113-60	---	TB139-10	TB127-14	TB135-16
110-120	60	TB113-1	TB113-3	TB113-61	TB130-13	TB139-1	TB127-20	TB135-1
110	50							
220-240	60	TB113-4	TB113-6	TB113-62	TB130-14	TB139-2	TB127-21	TB135-2
220	50							
380	60	TB113-65	TB113-64	TB113-63	TB130-3	TB139-3	TB127-3	TB135-3
	50	TB113-7	TB113-28	TB113-64	TB130-9	TB139-4	TB127-4	TB135-9
440-480	60	TB113-7	TB113-9	TB113-64	TB130-9	TB139-4	TB127-11	TB135-4
440	50							
550-600	60	TB113-16	TB113-11	TB113-66	TB130-6	TB139-6	TB127-6	TB135-6
550	50							
Volt -Amperes								
INRUSH	60	67	108	141	161	61	16	215
SEALED		23	36	47	53	16	8	35
INRUSH	50	51	93	124	180	51	Refer to Sales Office	180
SEALED		18	33	45	49	13		

RELAYS - 447

Control Relays

Description

Series 447 relays are designed for AC and DC circuits where high reliability, versatility of contact and operating coil combinations, compact size, and high speed operation are required. The 447 relays are available up to 8 convertible poles, current ratings to 30 amps AC and 20 amps DC.

Components (Table 1)

Baseand Coil Voltage		Cat. No.
4 Pole Base-	120 VAC Coil ¹	447-9402-11
	208 VAC Coil	447-9402-21
	240 VAC Coil	447-9402-31
	480 VAC Coil	447-9402-31
8 Pole Base-	120 VAC Coil ²	447-9801-11
	208 VAC Coil	447-9801-21
	240 VAC Coil	447-9801-21
4 Pole Base-	115 VDC Coil ¹	447-9405-13
	230 VDC Coil	447-9405-23
8 Pole Base-	115 VDC Coil ²	447-9805-13
	230 VDC Coil	447-9805-23

- 1 Heavy Duty Coil, Suitable For Up To 4 Circuits
 2 Heavy Duty Coil, Suitable For Up To 8 Circuits

Notes:

Other AC and DC coil voltages are available.
 Please contact factory.



4-Pole Base

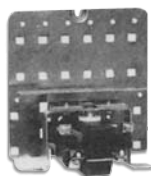

8-Pole Base

Unit Poles - AC Load (Table 2) 460VAC Max

Description	Cat. No.
10A, N.O.	447-9046
10A, N.C.	447-9047
20A, N.O.	447-9048
20A, N.C.	447-9049
30A ³ N.O.	447-9071
30A ³ N.C.	447-9072

³ Tungsten or Resistive Loads,
 277 VAC Max.

Unit Poles - DC Load (Table 3) 250VDC Max

Description ⁴	Cat. No.
20A, N.O. 1-Blowout	447-9019
20A, N.O. 2-Blowout	447-9020
20A, N.C. 1-Blowout	447-9021
20A, N.C. 2-Blowout	447-9022

⁴ All DC contacts require a "Blowout Mechanism" to extinguish the "arc" during contact opening. See Rule "B" below.

Rules to Select and Install Contacts

A. When installing "AC" or "DC" contacts you should balance the mechanical load on the coil magnet preferably by placing the contacts together in the center and working your way out.

- For a 4-pole contact install the contacts in sequence per the diagram listed below.

3 2 1 4

- For an 8-pole contact install the contacts per this diagram.

5 3 2 1 4 6 8 7

B. When installing DC contacts, using the contact sequence above, the last contact on the left must have two blowouts.

All others will have only one.

Example:

If you have four contacts on the 4-pole base (table 1), number 3 must have two blowouts. If you have only two contacts, then number 2 must have two blowouts.

If you have six contacts on the 8-pole base (table 1), number 5 must have two blowouts.

Contacts seven and eight on the 8-pole base must have two blowouts.

Ordering Information

Select and Price Base and Power Plant and Unit Poles Separately.

1 - 447-9402-11

Example: 120 VAC 4 Pole relay with 2 N.O., 2 N.C., 10 Amp Poles.

2 - 447-9046

Dimensions: See Section H Page 6.

2 - 447-9047

LIGHTING CONTACTORS

Index

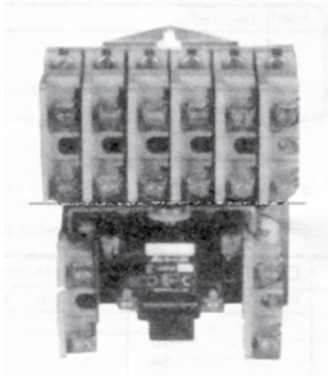

A

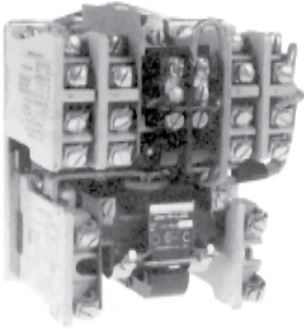

B



Description	Type	Page
20 Amp Electrically Held	PM	H2
30 Amp Electrically Held	PM	H3
20 Amp Electrically Held	447	H4
30 Amp Electrically Held	447	H4
30, 60, 100, 200 Amp Electrically Held	TM	H5
20 Amp Mechanically Held	PM	H2
30 Amp Mechanically Held	PM	H3
20 Amp Mechanically Held	447	H4
30 Amp Mechanically Held	447	H4
Dimensional Data - All		H6

Application

The Joslyn Clark Type PM - LC and LCL are magnetically operated lighting contactors designed to switch filament and ballast lighting loads as well as general purpose non-motor loads. Contactors are available in both electrically held and mechanically held versions. Coil-clearing contacts are furnished as standard on the mechanically held version to conserve energy, reduce heat, and eliminate AC hum.

The contactors are fully rated and are available in 20 amp and 30 amp ratings. The 20 amp is available up to 14 poles in electrically held and up to 10 poles mechanically held. The 30 amp is available up to 8 poles in both the electrically held and mechanically held versions. All power contacts are anti-weld type.

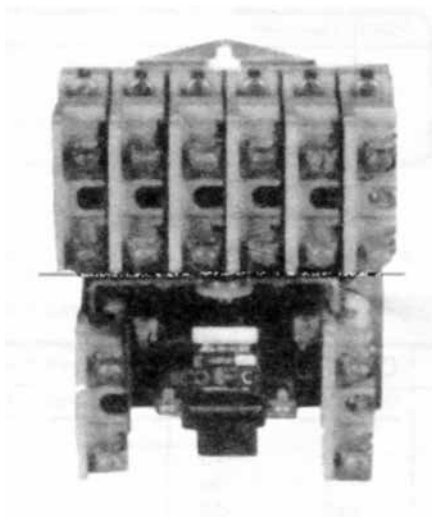

A



B

LIGHTING CONTACTORS

Type PM - LC & LCL

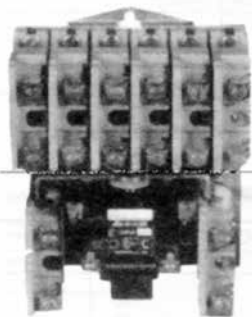

Typical 20 Ampere
Electrically Held Lighting
Contactor, 8-Pole

*** Notes:**

Only the KPM-33A (N.O.) and KPM-34A (N.C.) can be located on the bottom of the contactor beside the coil. All other contacts are above.

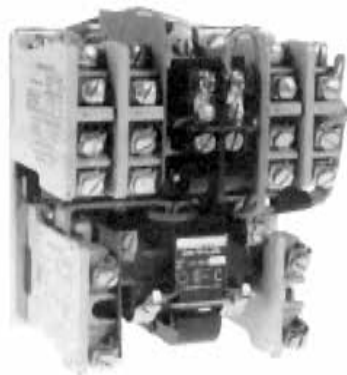

Typical 20 Ampere
Mechanically Held
Lighting Contactor, 8-Pole

Lighting Contactors - LC & LCL 20 Ampere - Bulletin 7707LC

Poles	N.O.	N.C.	Electrically Held - 20 Ampere			Mechanically Held - 20 Ampere		
			NEMA Type 1 General Purpose	Dim.	Open Catalog No.	NEMA Type 1 General Purpose Catalog No.	Dim.	Open Catalog No.
2	2	0	LC20A0020 - *	A	LC20U0020 - *	LCL20A0020 - *	B	LCL20U0020 -
2	1	1	LC20A0011 - *	A	LC20U0011 - *	LCL20A0011 - *	B	LCL20U0011 -
3	3	0	LC20A0030 - *	A	LC20U0030 - *	LCL20A0030 - *	B	LCL20U0030 -
3	2	1	LC20A0021 - *	A	LC20U0021 - *	LCL20A0021 - *	B	LCL20U0021 -
3	1	2	LC20A0012 - *	A	LC20U0012 - *	LCL20A0012 - *	B	LCL20U0012 -
4	4	0	LC20A0040 - *	A	LC20U0040 - *	LCL20A0040 - *	B	LCL20U0040 -
4	3	1	LC20A0031 - *	A	LC20U0031 - *	LCL20A0031 - *	B	LCL20U0031 -
4	2	2	LC20A0022 - *	A	LC20U0022 - *	LCL20A0022 - *	B	LCL20U0022 -
6	6	0	LC20A0060 - *	A	LC20U0060 - *	LCL20A0060 - *	C	LCL20U0060 -
6	5	1	LC20A0051 - *	A	LC20U0051 - *	LCL20A0051 - *	C	LCL20U0051 -
6	4	2	LC20A0042 - *	A	LC20U0042 - *	LCL20A0042 - *	C	LCL20U0042 -
6	3	3	LC20A0033 - *	A	LC20U0033 - *	LCL20A0033 - *	C	LCL20U0033 -
8	8	0	LC20A0080 - *	B	LC20U0080 - *	LCL20A0080 - *	C	LCL20U0080 -
8	7	1	LC20A0071 - *	B	LC20U0071 - *	LCL20A0071 - *	C	LCL20U0071 -
8	6	2	LC20A0062 - *	B	LC20U0062 - *	LCL20A0062 - *	C	LCL20U0062 -
8	5	3	LC20A0053 - *	B	LC20U0053 - *	LCL20A0053 - *	C	LCL20U0053 -
8	4	4	LC20A0044 - *	B	LC20U0044 - *	LCL20A0044 - *	C	LCL20U0044 -
10	0-10		LC20A0100 - *	B	LC20U0100 - *	LCL20A0100 - *	C	Contact Factory
12	0-12		LC20A0120 - *	C	LC20U0120 - *	Not Available		Not Available
14	0-14		LC20A0140 - *	C	LC20U0140 - *	Not Available		Not Available

Contact Kits - Discount Schedule JC 55

Type of Operation	Type of Contact	Operating Rod Color	N.O. or N.C. Contacts	Kit Catalog No.	Location
Non-Overlap	Anti-Weld	White	1-NO	KPM-31A	Top
Non-Overlap	Anti-Weld	White	1-NC	KPM-32A	Top
Non-Overlap	Anti-Weld	White	1-NO	KPM-33A	*Bottom
Non-Overlap	Anti-Weld	Red	1-NO/1-NC	KPMA-2	Top
Overlapping	Std. Silver	Orange	1-NO/1-NC	KPMA-21	Top
Non-Overlap	Anti-Weld	Green	2-NO	KPMF-2	Top
Non-Overlap	Anti-Weld	White	1-NC	KPM-34A	*Bottom

Factory Modifications - NEMA Type 1

Form	Description
B	3 position selector switch
K	2 position selector switch
C	On/Off Pushbuttons - uses one pole space for holding circuit.

Accessories

- Enclosures - NEMA 1 and NEMA 3R - see Page L6
- * See note at top of page for location of contacts

Ordering Information

- Use complete catalog number. Replace the (*) with the suffix from Coil Table.
- For a NEMA 3R, (2 to 8 Poles Only) replace the "A" or "U" with an "R".
Example: LCL20 R 0040
- For cover mounted operators, replace letter "O" with form letter.
Example: 3 Pos. sel. sw., LC20A B 040 -*.

Coil Table

60 Hz Voltage	Suffix	DC Voltage	Suffix
24	-96	24	-024
120	-76	120	-120
208	-86	240	-240
240	-26	12	-012
277	-277	32	-032
480	-46	64	-064
600	-56		

LIGHTING CONTACTORS

Type PM - LC & LCL

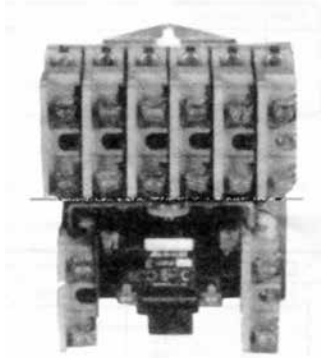

Typical 30 Ampere
Mechanically Held Lighting
Contactor, 8-Pole

* Notes: Only the KLC-33A (N.O.) and KLC-34A (N.C.) can be located on the bottom of the contactor beside the coil. All other contacts are above.

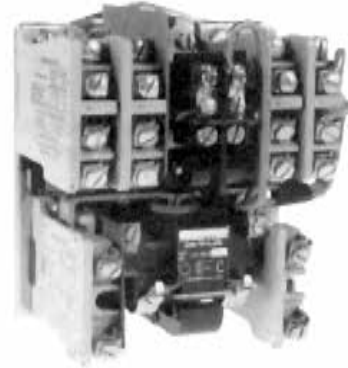

Typical 30 Ampere
Electrically Held Lighting
Contactor, 8-Pole

Lighting Contactors - LC & LCL 30 Ampere - Bulletin 7707LC

Poles	N.O.	N.C.	Electrically Held - 30 Ampere			Mechanically Held - 30 Ampere		
			NEMA Type 1 General Purpose	Dim.	Open Catalog No.	NEMA Type 1 General Purpose Catalog No.	Dim.	Open Catalog No.
2	2	0	LC30A0020 - * A	A	LC30U0020 - *	LCL30A0020 - * B	B	LCL30U0020 -
2	1	1	LC30A0011 - * A	A	LC30U0011 - *	LCL30A0011 - * B	B	LCL30U0011 -
3	3	0	LC30A0030 - * A	A	LC30U0030 - *	LCL30A0030 - * B	B	LCL30U0030 -
3	2	1	LC30A0021 - * A	A	LC30U0021 - *	LCL30A0021 - * B	B	LCL30U0021 -
3	1	2	LC30A0012 - * A	A	LC30U0012 - *	LCL30A0012 - * B	B	LCL30U0012 -
4	4	0	LC30A0040 - * A	A	LC30U0040 - *	LCL30A0040 - * B	B	LCL30U0040 -
4	3	1	LC30A0031 - * A	A	LC30U0031 - *	LCL30A0031 - * B	B	LCL30U0031 -
4	2	2	LC30A0022 - * A	A	LC30U0022 - *	LCL30A0022 - * B	B	LCL30U0022 -
6	6	0	LC30A0060 - * A	A	LC30U0060 - *	LCL30A0060 - * C	C	LCL30U0060 -
6	5	1	LC30A0051 - * A	A	LC30U0051 - *	LCL30A0051 - * C	C	LCL30U0051 -
6	4	2	LC30A0042 - * A	A	LC30U0042 - *	LCL30A0042 - * C	C	LCL30U0042 -
6	3	3	LC30A0033 - * A	A	LC30U0033 - *	LCL30A0033 - * C	C	LCL30U0033 -
8	8	0	LC30A0080 - * B	B	LC30U0080 - *	LCL30A0080 - * C	C	LCL30U0080 -
8	7	1	LC30A0071 - * B	B	LC30U0071 - *	LCL30A0071 - * C	C	LCL30U0071 -
8	6	2	LC30A0062 - * B	B	LC30U0062 - *	LCL30A0062 - * C	C	LCL30U0062 -
8	5	3	LC30A0053 - * B	B	LC30U0053 - *	LCL30A0053 - * C	C	LCL30U0053 -
8	4	4	LC30A0044 - * B	B	LC30U0044 - *	LCL30A0044 - * C	C	LCL30U0044 -

Factory Modifications - NEMA Type 1

Form	Description
B	3 position selector switch
K	2 position selector switch
C	On/Off Pushbuttons - uses one pole space for holding circuit.

Contact Kits - Discount Schedule JC 55

Type of Operation	Type of Contact	Operating Rod Color	N.O. or N.C. Contacts	Kit Catalog No.	Location
Non-Overlap	Anti-Weld	White	1-NO	KLC-31A	Top
Non-Overlap	Anti-Weld	White	1-NC	KLC-32A	Top
Non-Overlap	Anti-Weld	White	1-NO	KLC-33A	*Bottom
Non-Overlap	Anti-Weld	Red	1-NO/1-NC	KLCA-2	Top
Overlapping	Std. Silver	Orange	1-NO/1-NC	KPMA-21	Top
Non-Overlap	Anti-Weld	Green	2-NO	KLCF-2	Top
Non-Overlap	Anti-Weld	White	1-NC	KLC-34A	*Bottom

Accessories

- Enclosures - NEMA 1 and NEMA 3R - see Page L6
- * See note at top of page for location of contacts

Ordering Information

- Use complete catalog number. Replace the (*) with the suffix from Coil Table.
- For a NEMA 3R, (2 to 8 Poles Only) replace the "A" or "U" with an "R".
Example: LCL20 R 0040
- For cover mounted operators, replace letter "O" with form letter.
Example: 3 Pos. sel. sw., LC30A B 044 -*

Coil Table

60 Hz Voltage	Suffix	DC Voltage	Suffix
24	-96	24	-024
120	-76	120	-120
208	-86	240	-240
240	-26	12	-012
277	-277	32	-032
480	-46	64	-064
600	-56		

LIGHTING CONTACTORS

447 Series

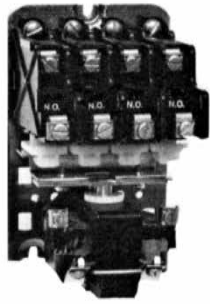

Typical 30 Amp.
Electrically Held Lighting
Contactor, 4-Pole

Application

Series 447, 20 & 30 Ampere contactors are engineered for a wide variety of lighting circuit switching where long-life, compact size and versatility of contact combinations are prime application requirements. The 20 Ampere and 30 Ampere contactors are available as electrically held types, and do not require coil clearing contacts. Both sizes are City of L.A. approved.

Description

These Lighting Contactors are magnetically operated with contact poles electrically held. Parts are compactly arranged on a steel mounting plate - one size plate accommodates 4 poles or less and another for 5 poles or more. The N.O. unit poles, with the same basic construction on all sizes, have a molded insulating housing enclosing the contacts for environmental protection. Wiping action, double break silver alloy contacts for positive make, fast break are standard. A single screw fastens each unit pole to the base plate.

All terminals are accessible and are equipped with pressure connectors (accommodating two No. 12 or 14 solid or stranded wires) for reliable, shakeproof connections.

Sub-Assemblies

In addition to the contactors listed in the table below, sub-assemblies are available allowing fast, easy assembly of complete contactors by the customer to meet job requirements.

For Sub-Assemblies please see page G18

H

Lighting Contactors - Series 447 - 20 & 30 Ampere

Poles	20 Ampere		30 Ampere	
	Amperes Open or Encl. 277V/60Hz	Electrically Held Open Catalog No.	Amperes Open or Encl. 277V/60Hz	Electrically Held Open Catalog No.
2	20	447-5200 - *	30	447-6200 - *
3		447-5300 - *		447-6300 - *
4		447-5400 - *		447-6400 - *
6		447-5600 - *		447-6600 - *
8		447-5800 - *		447-6800 - *

Ordering Information

To order use complete catalog number. Replace the (*) with the suffix from the coil table.

Coil Table

60 Hz/Voltage	Suffix
120	11
208-240	21

LIGHTING CONTACTORS

Type TM - LC

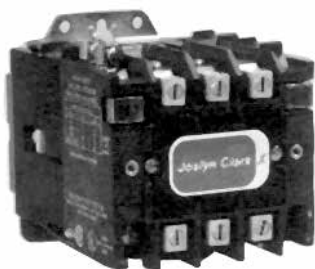

Open Type Lighting Contactor

Application

The Joslyn Clark Type TM-LC Lighting Contactors are electrically held and specifically designed for use on filament and ballast (fluorescent and mercury) lamp loads. For such loads, all 770LC Lighting Contactors may be used at their full ampere ratings.

Factory Modifications - NEMA Type 1

Form	Description
B	3 position selector switch
K	2 position selector switch
C	On/Off Pushbuttons - uses one pole space for holding circuit.

Accessories

- Enclosures - NEMA 1 and NEMA 3R

Lighting Contactors - Type TM - LC

Full Load Ampere Rating ^{2,3}	No. of Poles	Open Type Catalog No. ¹	NEMA Type 1 General Purpose Catalog No. ¹
30	2	T77U02B	T77A02B
	3	T77U03B	T77A03B
60	2	T77U02C	T77A02C
	3	T77U03C	T77A03C
200 ³	2	T77U02E	T77A02E
	3	T77U03E	T77A03E

Auxiliary Contacts:
KTM-10 N.O. x JC14
KTM-11 N.C. x JC14



- Includes contactor without control-circuit contact.
- Maximum a-c voltage ratings, single or polyphase:
Tungsten load - 480V, Ballast load - 600V.
For use of aluminum wire on other sizes, refer to sales office.
- 200 Ampere Contactor is UL Listed for Ballast Lamp Loads only.

Ordering Information

- To order use complete catalog number. Replace the (*) with the suffix from the coil table.
- For a NEMA 3R, replace the "A" or "U" with an "R".
- For cover mounted operators, replace letter "0" with form letter.
Example: 3 Pos. sel. sw., T77A B 3B -*.

Coil Table

60 Hz/Voltage	Suffix
24	-96
120	-76
208	-86
240	-26
277	-277
480	-46

LIGHTING CONTACTORS

447 Series

Approximate Dimensions In Inches Type PM-LC & LCL & TM-LC Contactors

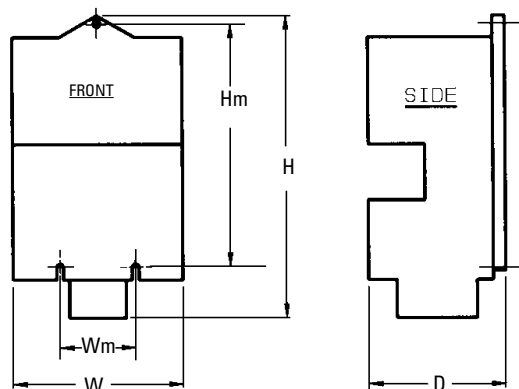

Open - Series 447

¹ Contactor Type	Max. Poles	H	W	D	Hm	Wm
447	4	5 1/16	3 1/4	3 1/8	4 3/4	2 1/8
Elec. Held	8	5 11/16	5 1/8	3 1/8	4 3/4	2 1/8

Open - Type PM - LC & LCL

¹ Contactor Type	Ref Dim	H	W	LC D	LCL D	Hm	Wm
LC & LCL	A	5 5/16	3	3 1/4	3 5/8	4 1/2	2
LC & LCL	B	5 5/16	4 1/2	3 1/4	3 5/8	4 1/2	2
LC & LCL	C	5 7/16	4 1/2	3 1/4	3 5/8	4 1/2	2

Open - Type TM - LC

Contactor Type	No. of Poles	H	W	D	Hm	Wm
¹ 30A, 60A	2, 3	4 1/4	3 7/8	4 3/4	3 3/4	1 1/2
² 200A	2, 3	8 1/8	5 7/16	7 1/16	6 7/8	3 1/2

H

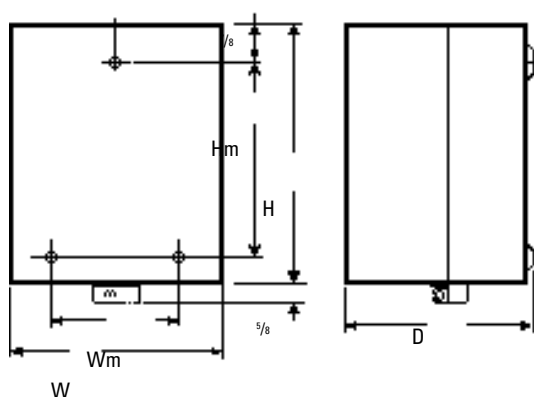

NEMA Type 1 Enclosure

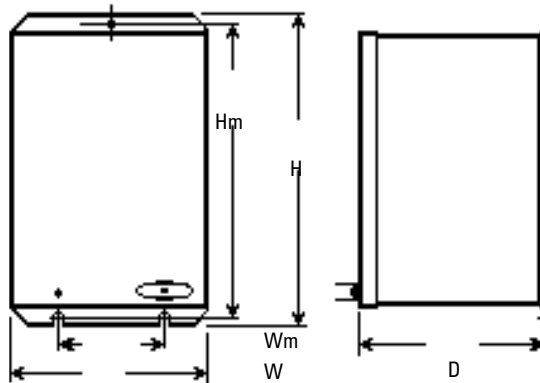

NEMA Type 3R Enclosure

Enclosed- Type PM - LC & LCL & Type TM - LC

Enclosure NEMA Type	Maximum number of poles					Enclosure Dimensions				
	LC20	LCL20	LC,LCL30	TM 30, 60	TM 100, 200	H	W	D	Hm	Wm
¹ Type 1	8	8	4	4	---	9 1/2	6 3/4	6 1/4	7 3/4	5
¹ Type 1	14	10	8	---	---	14 1/2	12 5/8	6 1/4	12 3/4	11
² Type 1	---	---	---	---	4	20	12	9	17	9
² Type 3R	8	8	4	4	---	11	7 1/4	6 7/8	10 1/2	4

Notes:

1. Provisions for #10 Mounting Screws.
2. Provisions for 1/4" Mounting Screws.

REPLACEMENT COILS

Index

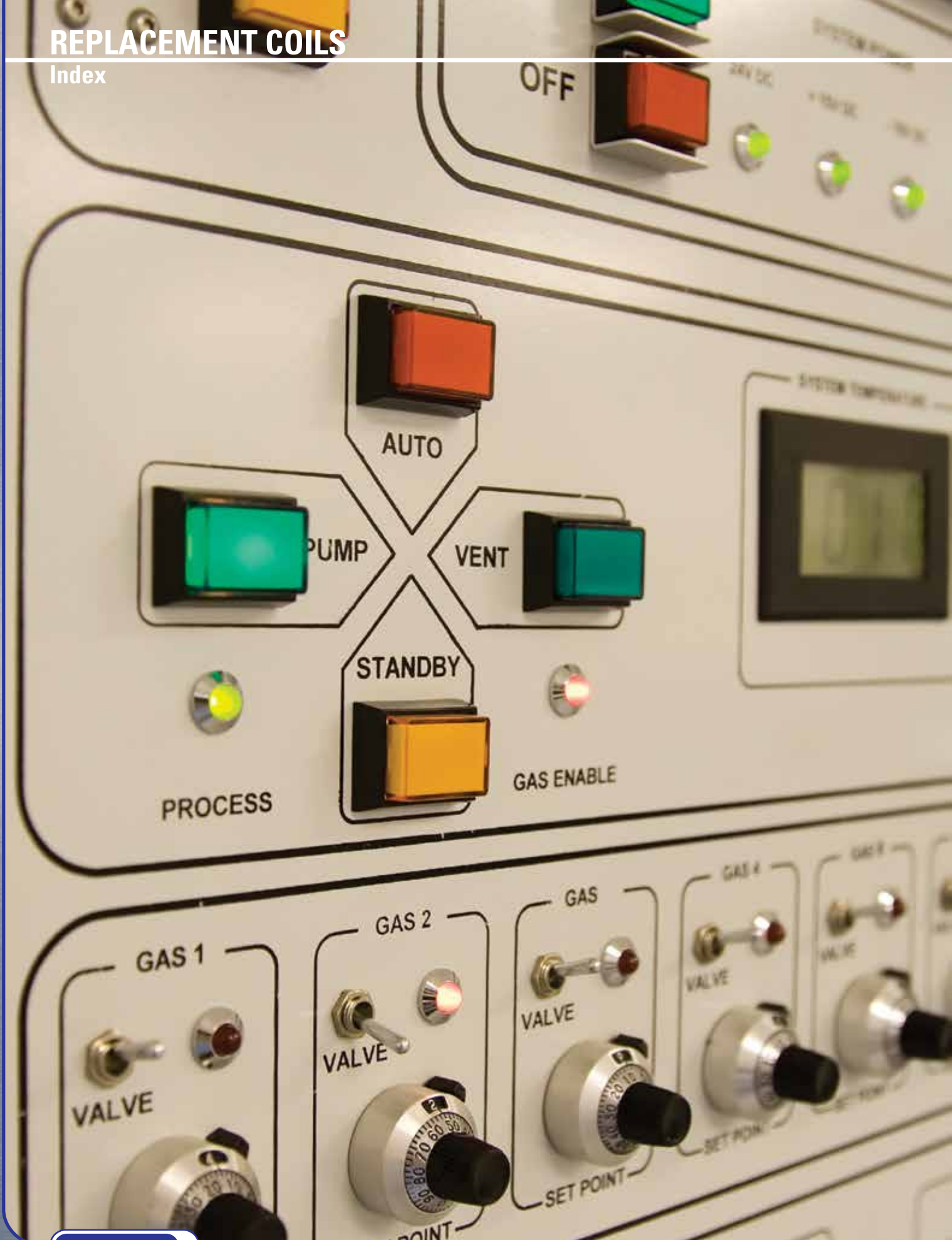

Description	Coil Prefix.....	Page Number
PM Magnetic Relays, DC Operated	TB137-	3
PM, PMA, PMF, PML, PMAL Magnetic Relays	TB113-	2
PMA, PMF, PMAL Magnetic Relays	TB130-	2
PMS Magnetic Relays.....	TB139-	3
PML, PMAL Magnetic Latch Relays	TB127-	2
PMT Pneumatic Timing Relays, Class A, Folio 2.....	TB135-	3
PMT Pneumatic Timing Relays, Class A,..... (non-Folio 2) and Class B	TB130-	2
PMT Pneumatic Timing Relays, DC Operated	TB140-	3
(3 Lead)		
PMT Pneumatic Timing Relays, DC Operated	TB137-	3
(2 Lead)		
TM-00-2 Magnetic Magnetic	TB159-	4
Starters & Contactors		
HP & HPF-00-2 & 1 Magnetic Starters & Contactors	TB174-	3
TM-3 & TM-4 Magnetic Starters & Contactors	TB162-	4
U-5 Magnetic Starters & Contactors.....	335L-	4
447 Magnetic Relays, DC Operated	TB137-	3
447 Magnetic Relays, AC Operated	TB113-	2
LC20, LC30, Lighting Contactors.....	TB113-	2
LCL20, LCL30, Lighting Contactors.....	TB113 (Main), TB127 (Trip)....	2
5000A, Size 00-1 Contactor & Starters	344L.....	5
5000A, Size 2 Contactor & Starters	343L.....	5
5000A, Size 3 Contactor & Starters	319L.....	5
5000-, Size 4 Contactor & Starters	320L.....	5
5000-, Size 5 Contactor & Starters	335L.....	5
5000-, Size 2 Contactor & Starters	319L.....	5
5000-, Size 3 Contactor & Starters	320L.....	5
7000, 7001 DC Contactor, AC Operation.....	344L.....	5
5DP1, 5DP2, 5DP3A DC Contactors AC Operated	319L.....	5
5DP7 DC Contactors AC Operation	343L.....	5
5DP3-, 5DP4, 5DP9 DC Contactors AC Operation	320L.....	5
5DP5-5DP8 DC Contactor AC Operated	335L.....	5

REPLACEMENT COILS

Numerical Coil Data

Description	Coil	Volts	Hertz	Load Factor
For Use With Series: 447, LC20, LC30, PM, PMA, PMF, PMAL	TB113-1	110-120	60	20-72
	TB113-3	110-120	60	73-144
	TB113-3	110-120	50	145-192
	TB113-4	220-240	60	20-72
	TB113.4	277	60	73-144
	TB113-6	277	60	145-192
	TB113-6	220-240	60	73-144
	TB113-6	220-240	50	145-192
	TB113-7	380	50	20-72
	TB113-7	440-480	60	20-72
	TB113-7	550	60	73-144
	TB113-7	550	50	145-192
	TB113-9	440-480	60	73-144
	TB113-9	440-480	50	145-192
	TB113-11	600	60	73-144
	TB113-11	600	50	145-192
	TB113-15	277	60	20-72
	TB113-16	600	60	20-72
	TB113-36	24	60	20-72
	TB113-37	24	60	73-144
	TB113-39	12	60	20-72
	TB113-40	12	60	73-144
	TB113-60	24	60	145-192
	TB113-61	110-120	60	145-192
	TB113-62	220-240	60	145-192
	TB113-64	380	60	73-144
	TB113-64	380	50	145-192
	TB113-64	440-480	60	145-192

Description	Coil	Volts	Hertz
For Use With Series: LCL20, LCL30, PML, PMAL (Trip Coil)	TB127-1	110	60
	TB127-2	220	60
	TB127-2	115-230	DC
	TB127-2	180	DC
	TB127-4	440	60
	TB127-5	550	60
	TB127-6	550-600	60
	TB127-11	440-480	60
	TB127-14	24	60
	TB127-15	12	60
	TB127-20	110-120	60
TB127-21	220-240	60	

Description	Coil	Volts	Hertz	Load Factor
For Use With Series: PMT *, PMA, PMF, PMAL	TB130-1	110	60	
	TB130-2	208-220	60	
	TB130-6	600	60	193-240
	TB130-9	440-480	60	193-240
	TB130-12	24	60	
	TB130-13	120	60	
	TB130-13	110-120	60	193-240
	TB130-14	240	60	
	TB130-14	220-240	60	193-240

Notes:

TB130 coils are used on Bul. 7313 Timing Relays not marked "Folio 2". This includes original Class A timers and all Class B timers. See TB135 coils for Class A, Folio 2 timers.

J

REPLACEMENT COILS

Numerical Coil Data

Description	Coil	Volts	Hertz
For Use With Series: PMT *	TB135-1	110	60
	TB135-2	208-220	60
	TB135-3	380	60
	TB135-4	440	60
Discount Schedule JC80	TB135-5	550	60
	TB135-6	600	60
	TB135-9	380	50
	TB135-16	24	60

Description	Coil	Volts	
For Use With Series: PMT (DC) Folio 2	TB140-1	115-120	DC
Discount Schedule JC80	TB140-2	230-250	DC

Notes:

TB135 coils are used on Bul. 7313 Timing Relays marked "Folio 2". See TB130 coils for timers not marked "Folio 2".

Description	Coil	Volts	
For Use With Series: PM, 447, PMT (DC 2 Lead)	TB137-2	240	DC
	TB137-5	64	DC
	TB137-6	48	DC
	TB137-7	32	DC
	TB137-8	24	DC
	TB137-9	12	DC
	Timers Only Discount Schedule JC80	TB137-12	120
TB137-13		240	DC
TB137-14		95	DC

Description	Coil	Volts	Hertz
For Use With Series: PMS	TB139-1	110-120	60
	TB139-2	220-240	60
Discount Schedule JC80	TB139-3	380	60
	TB139-4	440-480	60
	TB139-4	380	50
	TB139-6	550-600	60
	TB139-10	24	60

Description	Coil	Volts	Hertz	Poles
For Use	TB174-1	120	50/60	2, 3
With Series:	TB174-2	208-240	50/60	2, 3
HP/HPF	TB174-3	24	50/60	2, 3
(Size 00-2)	TB174-4	277	50/60	2, 3
Discount	TB174-5	480	50/60	2, 3
JC80	TB174-6	600	50/60	2, 3
	TB174-7	380	50/60	2, 3

J

REPLACEMENT COILS

Numerical Coil Data

Description	Coil	Volts	Hertz	Poles
For Use	335L1	110-120	60	2, 3
With: U5	335L1	110	50	2, 3
(U Series	335L2	220-240	60	2, 3
Only)	335L3	440-480	60	2, 3
Discount Schedule	335L3	440	50	2, 3
JC27	335L4	550-600	60	2, 3
	335L4	550	50	2, 3
	335L7	200-208	60	2, 3

Notes:

These size 5's are not interchangeable

Description	Coil	Volts	Hertz	Size
	TB162-1	110-120	60	4
For Use	TB162-1	110	50	4
With Series:	TB162-2	220-240	60	4
TM -3,4	TB162-2	220	50	4
	TB162-3	440-480	60	4
Discount Schedule	TB162-3	440	50	4
JC80	TB162-4	550-600	60	4
	TB162-4	550	50	4
	TB162-7	110-120	60	3
	TB162-7	110	50	3
	TB162-8	220-240	60	3
	TB162-8	220	50	3
	TB162-9	440-480	60	3
	TB162-9	440	50	3
	TB162-13	277	60	3
	TB162-14	200-208	60	3
	TB162-14	110-120	25	3
	TB162-15	380	50	3
	TB162-15	220-240	25	3
	TB162-16	200-208	60	4
	TB162-16	110-120	25	4
	TB162-17	380	50	4
	TB162-17	220-240	25	4

Description	Coil	Volts	Hertz	Poles
	TB159-1	110-120	60	2, 3, 4
For Use	TB159-1	110	50	2, 3, 4
With Series:	TB159-2	220-240	60	2, 3, 4
TM (Size 00,	TB159-2	220	50	2, 3, 4
0, 1, 2)	TB159-3	440-480	60	2, 3, 4
	TB159-3	440	50	2, 3, 4
Discount Schedule	TB159-4	550-600	60	2, 3, 4
JC80	TB159-4	550	50	2, 3, 4
	TB159-9	24	60	2, 3, 4
	TB159-10	200-208	60	2, 3, 4
	TB159-11	380	50	2, 3, 4
	TB159-13	277	60	2, 3, 4

J

REPLACEMENT COILS

Numerical Coil Data

Description	Coil	Volts	Hertz
	344L1	110-120	60
For Use	344L1	110	50
With Series:	344L5	220-240	60
5000A*, 7000,	344L3	440-480	60
7001, 8000B	344L3	440	50
(Size 00, 0, 1,	344L4	550-600	60
10/40 Amp,	344L4	550	50
40 Amp)	344L6	24	60
	344L2	200-208	60

Description	Coil	Volts	Hertz
	335L1	110-120	60
For Use	335L1	110	50
With Series:	335L2	220-240	60
5000-*, 5DP5,	335L2	220	50
5DP8	335L3	440-480	60
(Size 5	335L3	440	50
360,535 Amp)	335L4	550-600	60
	335L7	208	60

Description	Coil	Volts	Hertz
	343L1	110-120	60
For Use	343L2	220-240	60
With Series:	343L2	220	50
5000A*, 5DP7,	343L3	440-480	60
8000B	343L3	440	50
(Size 2	343L4	550-600	60
75 Amp)	343L4	550	50
	343L5	208	60

Description	Coil	Volts	Hertz
For Use	320L1	110-120	60
With Series:	320L1	110	50
5000-*,	320L2	220-240	60
5DP3-*,	320L3	440-480	60
5DP4, 5DP9,	320L3	440	50
8000B	320L4	550-600	60
(Size 4 110*,	320L4	550	50
180,260 Amp)	320L2	200-208	60

Description	Coil	Volts	Hertz
	319L1	110-120	60
For Use	319L1	110	50
With Series:	319L2	220-240	60
5000A*, 5DP1,	319L3	440-480	60
5DP2, 8000B, 5DP3A*	319L3	440	50
(Size 3	319L4	550-600	60
30, 56,	319L4	550	50
110 * Amp)	319L5	24	60
	319L2	200-208	60

Notes:

Series 5DP3A 110 Amp., and 5DP3- 110 Amp., are not interchangeable
 Series 5000A and 5000- are not interchangeable

J

JOSLYN CLARK CONTROLS

Bulletin/Series Index

BULLETIN	Page	CONTROL RELAYS	
AC CONTACTORS MAGNETIC LOW VOLTAGE		7304 TYPE PM, CD CONVERTIBLE POLE	G12
7707 TM	B5	7305 TYPE PM RELAY FAMILY	G2
7707 HP	C4	447 SERIES	G18
5000 SERIES	B35	OVERLOAD RELAYS	
AC STARTERS MAGNETIC LOW VOLTAGE		7324 TYPE TM PANEL MOUNTING	B12
6012 TM	B7	LIGHTING CONTACTORS	
3013 HP	C4	7707-LC TYPE PM	H2
AC REVERSING MAGNETIC CONTACTORS LOW VOLTAGE		777-LC TYPE TM	H5
6031 TM	B6	447 SERIES	H4
6031 HP	C4	DC CONTROL	
AC REVERSING MAGNETIC STARTERS LOW VOLTAGE		146 FIELD LOSS RELAY	F2
6030 TM	B8	5000DP DC DEFINITE PURPOSE CONTACTORS	F4
6030 HP	C5	7000-7001 CD MAGNETIC CONTACTORS	F4
AC CONTACTORS VACUUM LOW VOLTAGE		7400 SERIES DC MAGNETIC CONTACTORS	F8
7707 VC	A20	RHEOSTATS	
7707 CV	A2, A8, A14	CALL FACTORY	F10
SUV	A29		
AC CONTACTOR VACUUM MED VOLTAGE			
MVC	A39		
SVC	A42		
AC STARTER VACUUM LOW VOLTAGE			
6013 TYPE CV	A5, A11, A17		
6013 TYPE VS13	A24		
AC LATCHING VACUUM CONTACTORS LOW VOLTAGE			
7707 TYPE VC	A21		
AC LATCHING VACUUM CONTACTORS MED VOLTAGE			
TYPE MCV	A40		
AC MECHANICALLY INTERLOCKED VACUUM CONTACTOR			
LOW VOLTAGE			
CV31	A3, A9, A15		
VC31	A22		
AC MECHANICALLY INTERLOCKED VACUUM CONTACTOR			
MED VOLTAGE			
TYPE MVC	A41		
AC REVERSING VACUUM CONTACTORS LOW VOLTAGE			
6031	A4, A10, A16, A23		
AC REVERSING VACUUM STARTERS LOW VOLTAGE			
6030	A6, A12, A18, A25		
PILOT DEVICES – PUSH-BUTTON CONTROLS			
100T 30 MM HEAVY DUTY	D1		
PUSH BUTTON STATIONS			
100-RN MILL TYPE	E12		
100 T HEAVY DUTY ENCLOSED	D13		
REMOTE SWITCHES			
101 FOOT SWITCHES	E9		
MASTER SWITCHES			
101 TYPE SD MILL MASTER JR.	E11		
LIMIT SWITCHES			
102-HL HATCHWAY TYPE HL & HD	E2, E3		
TIME DELAY RELAYS			
7313 TYPE PMT AC PNEUMATIC	G10		
7314 TYPE PMT DC PNEUMATIC	G14		

J

ALPHA-NUMERICAL INDEX

Of Catalog Number Prefixes

Prefix	Page	Prefix	Page	Prefix	Page
A60	C8	MVC	A39, A41	1RN	E12
A77	A2-A19, A36	MVCL	A40	100T	D1-D15
AK	A2-A19	MVF	A47	4U	G12
A101	E3, E9, E11	MVS	A46, A48	5DP	F4
A102	E2, E3, E5, E6, E7	SVC	A20, A29, A39,A42	5M	B36, F5, F6, F9
CV	A2-A19	T13	B7	5S	G8, G9
ETM	B19, B20	T30	B8	5U	G4, G5, G13
HLA	E2	T31	B6	146	F2
HLD	E3	T50	B8	319L	J5
HP	C5	T77	B5, H5	320L	J5
HPC	C4	T82	B11	335L	J4, J5
HPR	C5	TB	J1, J3, J4, J5	343L	J5
HPRC	C4	U82	B11	344L	J5
KHP	C6, C7,	U77	B5	447	G18, H4
KLC	H3	U13	B7	713U	G10, G15
KPM	G9, G11, H2, H3	VC	A20, A22, A23	714U	G14
KPMT	G11	VCL	A21	2411-2460	B13 - B14
KTB	C7	VJ	A25	2514-2541	B15
KTM	B12, B18, B19, B21, C6, H5	VS	A24, A25, A27, A28	5000	B35
KTR	B19, C7			5999	B36, F5, F6, F9
KUM	B19, B21			7000	F4
KVC	A2-A19, A36			7001	F4
LC	H2, H3			7400	F8
LCL	H2, H3				



Eagle Signal Controls

The Premier Name in Timers

Accuracy and reliability are the name of the game when it comes to timers. You have to be able to trust that the run time, production time and process time will be just right every time. For over 70 years, Eagle Signal has been delivering that dependability with its complete line of mechanical, electromechanical and electronic timing devices. With unique innovations like the NEW MAX ADVANCED Count, Tach and Position Controller Series in addition to our long-standing products, Eagle Signal has a reputation with OEMs and design engineers for providing timing products they can trust.



VEEDER-ROOT

The Industry Standard in Counters

Veeder-Root offers the broadest selection of rugged and economical electronic, electromechanical and mechanical counters. Veeder products encompass a complete line of totalizing, preset and predetermining electronic counters as well as diverse process and rate indicators. Veeder-Root, the world's best known name in counters, has provided non-stop performance and production monitoring in industrial manufacturing applications for over 100 years.



Look no further than Thomson Nyliner

Since 1954, Thomson Molded Products Group has been an industry leader in high-quality bearings, fasteners and industrial solutions for clients in six different markets. Our line of standard and custom products uses a maintenance-free proprietary polymer specifically designed to reduce friction, isolate noise, dampen vibration, resist corrosion and lower operating costs for a range of industrial uses. In addition, we also custom manufacture a complete line of products including spacers, grommets, hole plugs, leveling feet, door glides, hooks, friction pads and shelf supports to specification.



Superior Electric

An unmatched reputation for excellence – our name says it all

When you need high-quality, high-reliability voltage or power control and conditioning products, don't make concessions. Superior Electric is your choice. Our products and engineered solutions are among the finest in the world. Superior Electric POWERSTAT® Variable Transformers are used across six continents in millions of installations, while our STABILINE® voltage regulators, surge protective devices, UPS and power conditioners continue to be the industry standard for users.



The Toughest Conditions Call for NAMCO Switches

When a situation calls for heavy-duty control switches, NAMCO switches are the answer. Our SNAP-LOCK® limit switches are renowned for exceptional quality and reliability under the harshest conditions. NAMCO was the first U.S. company to respond when non-contact electronic sensing was required in automotive assembly lines. This level of innovation and dependability has led NAMCO to be a recognized leader in high reliability electronic sensing. Even today NAMCO is the Number One global source for limit switches use in nuclear power plants qualified the meet NRC requirements.

Joslyn Clark 



Best-in-class solutions for today's global industrial automation market

Delivering high-quality products and efficient, cost-effective solutions to our customers is the driving force behind DanaHER Specialty Products.

By combining the resources and expertise of six core technology leaders, DSP is able to share people, processes, innovations and insight. That allows us to offer OEM's and end-users the finest products and technologies available today, all in one place.