

## Mechanical Motion Sensor 98940-A Series

### GENERAL DESCRIPTION

The No. 98940-A Series Mechanical Motion Sensor is a snap-acting valve operated by mechanical motion and designed for use with Robertshaw Engine Control components.

The sensor is used to vent a pneumatic signal when the trip lever is actuated.

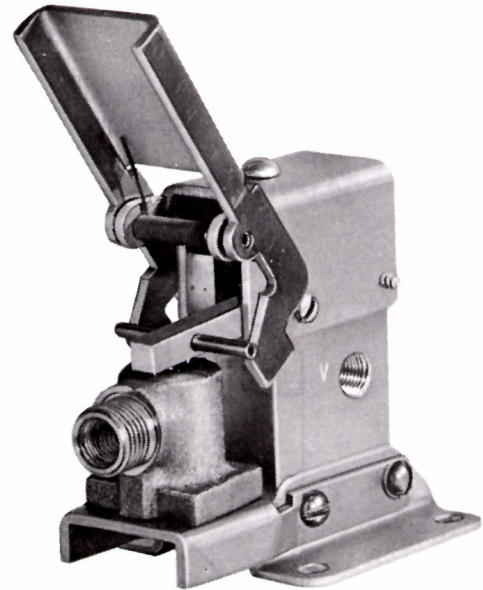

### SPECIFICATIONS

- Construction:** Brass body, stem and actuating lever. Elastomer O-rings. Steel trip-lever, cover and mounting brackets-cadmium plated and bi-chromate dipped. Stainless steel springs.
- Supply Pressure:** .....25 ± 5 psi. (max. 40 psi).  
*WARNING: Do not exceed maximum pressure.*
- Mounting:** .....Surface. (See Fig. 1)
- Connections:** .....1/8" - 27 NPT

- Models Available:**
- 98940-A2 - Manual Reset
- 98940-A3 - Pneumatic or Manual Reset

- Ordering Information:**
- Specify:
- (1) Model
- (2) Any special features

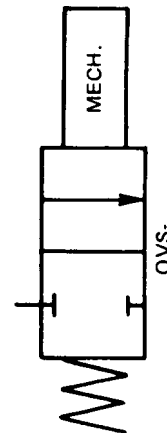

J.I.C. Symbol

# INSTALLATION

## A. GENERAL

Tubing and fittings used to connect sensor must be free of chips, dirt, moisture or other foreign matter. If compound or shellac is used, apply it above second or third male thread in moderate amount. Do not allow compound to be deposited inside sensor.

For continuous, trouble-free operation, the supply to the sensor must be clean and dry.

## B. MOUNTING

When installing the No. 98940 sensor, care must be taken to prevent any foreign matter from entering the ports.

The sensor may be installed in any position and should be securely mounted, using the four holes (clearance for No. 10 screws) provided in the mounting brackets. (See Fig. 1)

## C. CONNECTIONS

Consult system schematic.

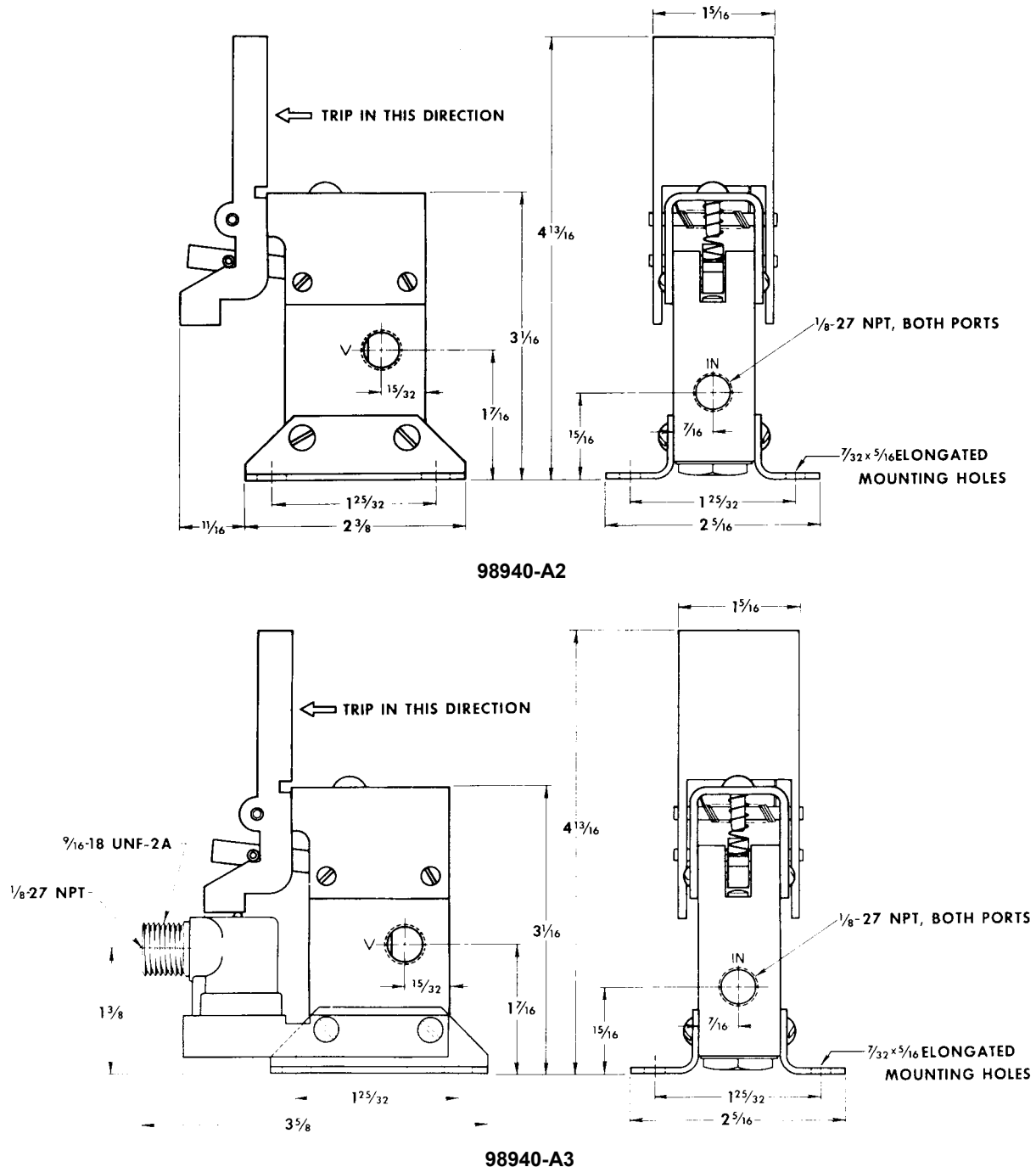

Figure 1

## OPERATION

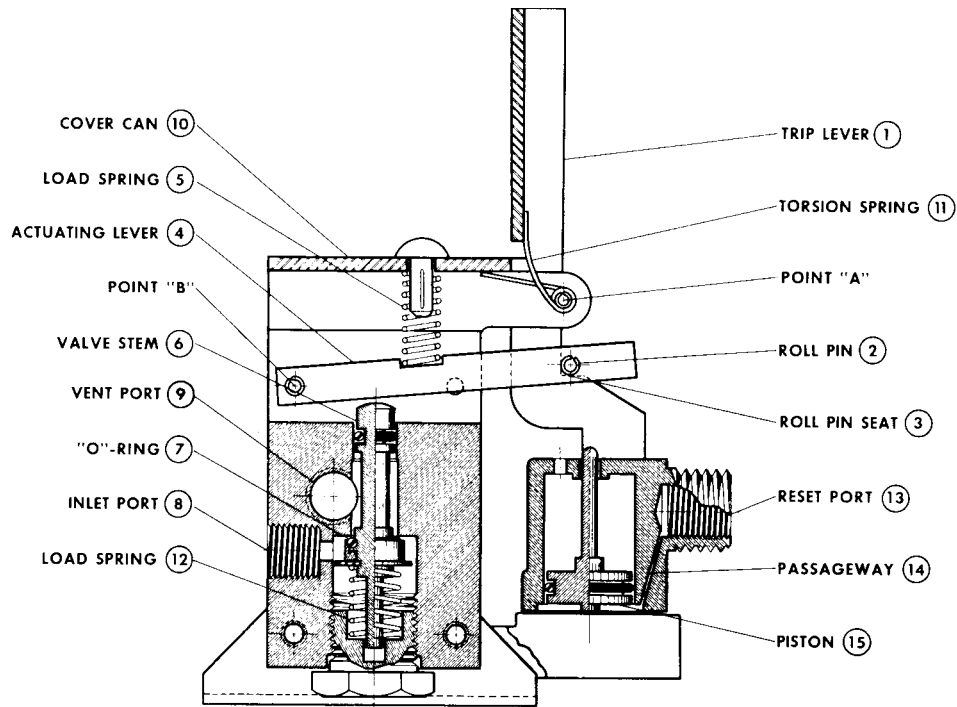

Figure 2

### A. TRIP CYCLE

The Trip Lever, which receives the force to be monitored, rotates about Point "A." The Actuating Lever, which actuates the valve, rotates around Point "B."

Sufficient force applied to Trip Lever (1) in the direction indicated causes it to rotate in a clockwise direction, allowing Roll Pin (2) to move out of Seat (3) and down incline. The roll pin, being connected to the Actuating Lever (4), is forced downward by Load Spring (S) acting on actuating lever. As actuating lever falls, it forces Valve Stem (6) downward, moving O-Ring (7) off seat. Pressure then flows from Inlet Port (8) out through Vent Port (9).

### B. RESET CYCLE

#### 1. Manual Reset (98940-A2):

With manual force applied in an upward direction to the trip lever, the roll pin travels up the incline and into Roll Pin Seat (3). Torsion Spring (11) provides a detent to hold trip lever in place. As the roll pin seats and the actuating lever moves upward, the valve stem is forced upward by Load Spring (12). This action permits O-ring to seat and blocks flow between Inlet and Vent Ports.

#### 2. Pneumatic Reset (98940-A3):

A signal supplied to Piston (15) through Reset Port (13), flows through Passageway (14) to bottom of piston, forcing the piston upward. The piston stem forces the actuating lever up, allowing the roll pin to move up the incline and into roll pin seat. Torsion Spring (11) furnishes the force necessary to rotate the trip lever counterclockwise. From this point the valve seating operation is the same as described in the manual operation (above).

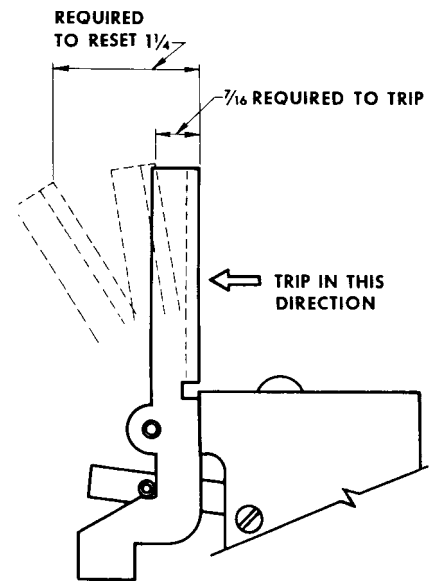

Figure 3

RELAY NO.	LOAD REQUIRED TO TRIP*	LOAD REQUIRED TO RESET*
98940-A2	1 lb.	6 lb.
98940-A3	1 lb.	Pneumatic Reset (20 psi min.)

\*Approximate values measured 2" from pivot point.

## MAINTENANCE

**WARNING:** *Disassemble carefully-spring-load forces present.*

If sensor does not function properly due to leakage or contamination by foreign matter, disassemble and clean all metal parts with non-flammable solvent and dry thoroughly.

After reassembly, check for external leakage. Retighten assembly screws as necessary. Gasket cement should not be used to seal leaks due to the possibility of plugging small passages.

## PARTS LIST

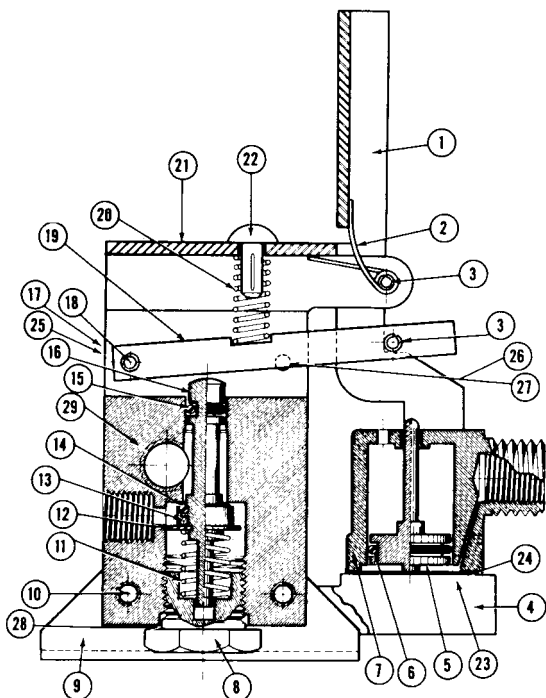

## CAUTION:

If cleaning is required, do not subject O-rings, poppets or gaskets to cleaning fluid, acetone, or any halogenated hydrocarbons such as vapor degrease liquids, etc. Clean only with a soft, dry cloth.

Upon reassembly, the O-rings should be lubricated with a silicone-type lubricant.

Do not permit lubricant to get on poppets or valve seats.

Item No.	No. Re'd	Description	Part No.
1	1	Lever	29846-A1
2	1	Torsion Spring	29850-A1
3	2	Roll Pin	36606-A14
4	1	Bracket	29841-A1
5	1	Piston	29843-A1
6	1	O-Ring	36240N0014
7	1	Cylinder	24513-A 1
8	1	Plug	24536-A1
9	2	Bracket	24637-A3
10	4	Screw	33713G1209
11	1	Spring	24537-A1
12	1	Retaining Ring	36605Q8
13	1	O-Ring Retainer	24534-A1
14	1	O-Ring	36240V0010
15	1	O-Ring	36240V0007
16	1	Stem	24531-A1
17	1	"E" Ring for Item No. 18	36605Q3
18	1	Pin	29844-A2
19	1	Lever	29848-A1
20	1	Spring	29845-A1
21	1	Cover	29849-A1
22	1	Drive-Stud	29851-A1
23	4	Reset Piston Mounting Screw (Not Shown)	33705-G1100
24	1	Gasket	24517-A1
25	1	Push-On Nut for Item No. 18	36603D2
27	2	Screw (Not Shown)	33711 L0902
28	1	Gasket	29623-A1
29	1	Relay Body	29840-A1

NOTE 1: 98940-A3 Shown. For 98940-A2, delete items 4, 5, 6, 7, 23, & 24.

NOTE 2: Items No. 1, 2, 3, 21, & 22 may be ordered assembled as "Lever Assembly 81838-A1."

# Robertshaw

**U.S.A. and CANADA**

Robertshaw Industrial Products Division

1602 Mustang Drive

Maryville, TN 37801

Phone: (865) 981-3100 Fax: (865) 981-3168

<http://www.robertshawindustrial.com>

## Exports

Invensys Appliance Controls

2809 Emerywood Parkway

P.O. Box 26544

Richmond, Virginia 23261-6544

Phone: (804) 756-6500 Fax: (804) 756-6561

Q-4020 (10/01)

Printed in U.S.A.