

Pressure Sensor No. 84374-Series

GENERAL DESCRIPTION

The patented* No. 84374-Series Pressure Sensor contains a weather-proof, snap-acting valve operated by pressure variation around the integral sensing element. Depending upon model used, it vents or blocks a pneumatic signal when the setpoint is reached and is available with either automatic or manual reset. The sensor has adjustable differential (auto reset versions only) and setpoint, provision for piped vent operation, and is field reversible. Setpoint is virtually unaffected by control pressure change or, in the case of piped vent versions, vent backpressure change. In the auto reset versions, reset differential can be changed without shifting setpoint.

For correct operation, control pressure must be provided thru a .81 mm (.032") diameter or smaller orifice.

*Patent 3,986,524



MODELS AVAILABLE

843714-
 Table 1  Table 2 

Table 1

Suffix	Description	Reset
A	Direct Acting - Vents on Increase	Auto
B	Reverse Acting - Closes Vent on Increase	Auto
C	Direct Acting - Vents on Increase	Manual

Table 2

Suffix	Setpoint Range - kPa (In. H z0)
1	1.7 - 7.0 (7 - 28)
2	3.5-17.5(14-70)



84374-A, C Series
 Vents on Increase
 (Direct-Acting)

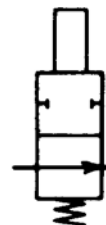

84374-B Series
 Closes Vent on Increase
 (Reverse-Acting)

J.I.C. Symbols

ORDERING INFORMATION

Specify:

1. Model
2. Control Pressure-If not specified, sensor is set using 207 kPa (30 psi).
3. Setpoint-If not specified, set as minimum.
4. Differential (Automatic Reset models only)-If not specified, set at standard.
5. Tagging Information

See Page 2 for SPECIFICATIONS

SPECIFICATIONS

Valve Housing, Housing Plate and Cover: Anodized Aluminum Alloy
Spring Housing: 316 Stainless Steel
Springs: Stainless Steel
O-Rings: Fluorocarbon and Neoprene
Diaphragms and Gasket: Buna-N on Nylon
Control Pressure: 138 to 414 kPa (20 to 60 psi)
Maximum Control Pressure: 172 kPa (25 psi)
Maximum Ambient Temperature: 71° C. (160° F.)
Repeatability: ± 1 % of setpoint
Approximate Shipping Weight: 1.4 Kg. (3.16 lbs.)
Control Medium: Air, Natural Gas, Nitrogen, CO₂
Filtration (Minimum):25 microns
Moisture (Pressure Dew Point): 8° C. (15° F.) less than ambient temperature.

Oil Content (Natural Base): 5 ppm
Oil Content (Synthetic Base): 0 ppm
NOTE: These are suggested minimums for control medium quality. For operation under more adverse conditions, consult factory.

CAUTION: DO NOT EXCEED MAXIMUM TEMPERATURE/PRESSURE RATINGS.

Reset Differential Range: See graph corresponding to instrument model numbers.

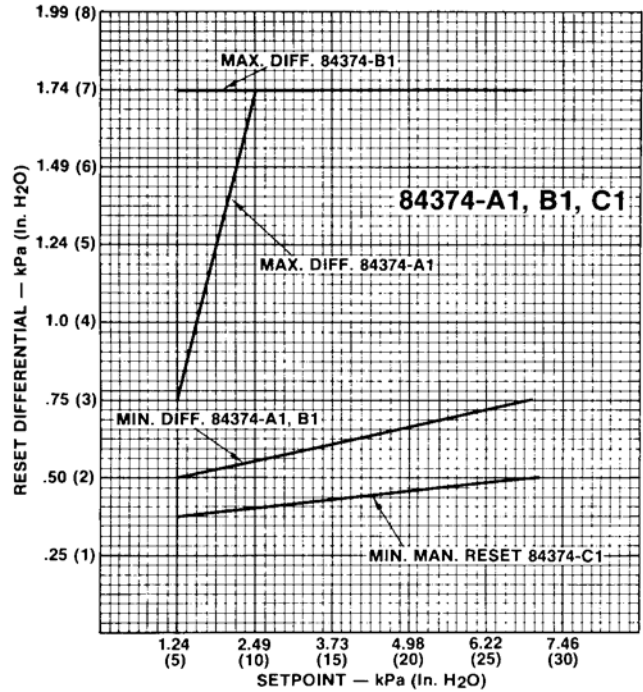

Process and Reset Pressure Characteristics:

Model No.	Maximum Process Pressure, kPa (psi)	Standard Reset Differential kPa (psi)	Minimum Process Pressure Drop to Manually Reset, kPa (psi)
84374-A1	172 (25)	5 (0.7)	
84374-A2	172 (25)	10 (1.5)	
84374-B1	172 (25)	5 (0.7)	
84374-B2	172 (25)	10 (1.5)	
84374-C1	172 (25)		2 (.3)
84374-C2	172 (25)		4 (.6)

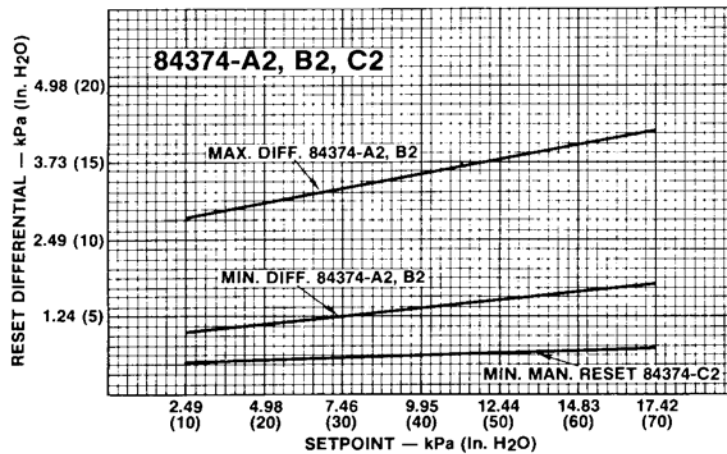

INSTALLATION

Mounting:

The No. 84374-Series Pressure Sensor may be mounted in any position, although vertical (upright) is recommended. It should be securely mounted on the panel using mounting bracket to prevent excessive vibration.

If the measured variable is a liquid, consideration should be given to the liquid level. An error in calibration could be caused by the weight of a body of liquid acting on the measuring assembly. It may be necessary to adjust calibration to compensate for the constant weight (See ADJUSTMENTS).

If the sensor is out of doors or in any way exposed to water, it should be mounted in a position that will prevent water entry into the valve or spring housings. Water trapped in the housing will impair operation and could freeze during winter months. Vent openings should have fittings installed turned down. The 1/8"-27 NPT vent connection can be used for piped vent operation if gas is used.

If the sensor is used with a liquid process pressure, entrapped air in tubing connected to the measuring assembly should be vented. This can be accomplished by bleeding the connection at the sensing element.

Connections:

1. The sensor has three 1/8"-27 NPT connections—one for control pressure, one for vent pressure and one for case relief pressure. A 1/4"-18 NPT connection is provided for the process pressure.

CAUTION: Do not pipe or plug case relief connection. The vent pressure connection from the sensor cannot be used as a supply or control source for any other equipment. Vent backpressure should be held to as low a level as possible.

Control port pressure must be provided through a .8 mm (.032") diameter or smaller orifice using 6 mm (1/4") or 9.5 mm (3/8") O.D. tubing. Using excessive lengths or other than the specified tubing, is not recommended.

Tubing and fittings used to connect the sensor must be free of chips, dirt, moisture or other foreign matter.

On fittings, it is recommended that a non-hardening, "anti-seize" type thread compound be applied to the threads in moderate amount. The first thread should then be wiped of excess to avoid compound being deposited inside the relay. Thread sealing tape is not recommended.

DIMENSIONS - Millimeters (Inches)

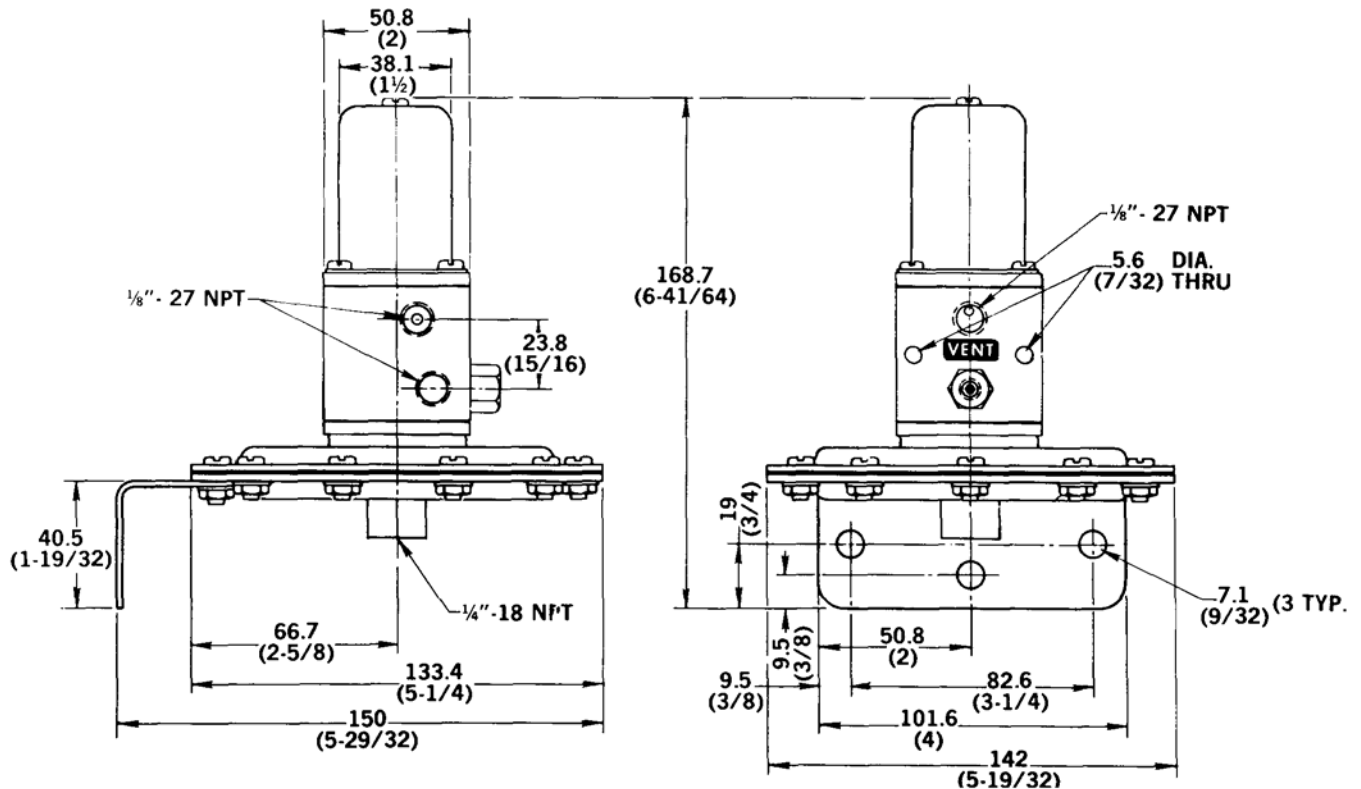

Figure 1
Direct Acting Shown

OPERATION (See Figure 2)

NOTE: For descriptive purposes the operation of the direct acting (automatic reset) sensor shown in Figure 2 will be explained. The operation of the reverse acting model is the same although reversed. It vents on a decrease in high process pressure.

As shown, pressure entering the CONTROL port of the sensor will flow around the stem and sleeve, through the bellows head, and out the VENT port. The bellows head is at the limit of its downward travel that is restricted by the reset/ differential adjustment screw. By limiting the downward travel of the bellows head, this adjustment screw defines how low the process pressure must drop before causing the sensor to reset and stop venting. (See Adjustments - Differential).

A decrease in the Process Pressure will cause the stem to travel downward as the force exerted downward on the stem by the range spring overrides the force exerted upward by the Process Pressure. The sleeve will travel downward with the stem until it seats on the O-ring in the bellows head.

When the sleeve seats on the O-ring, it will block the control pressure flowing around the stem and stop the venting of the sensor. The control pressure will then build around the outside of the bellows and cause the bellows to compress. As the bellows compresses, the bellows head will move upward carrying the sleeve with it until the tubular portion of the bellows head contacts the upper diaphragm seat.

When the bellows head seats, upward travel will be stopped and the sensor reset. The sensor will remain in this position unless the Process Pressure increases enough to overcome the force exerted by the range spring.

As the Process Pressure increases, the stem will be forced upward against the range spring until travel is sufficient to lift the sleeve off the O-ring in the bellows head. When the sleeve lifts off the O-ring, the pressure inside the bellows will equalize with the pressure on the outside of the bellows.

When the pressure on the inside is equal to the pressure on the outside, the bellows will attempt to recover to its free length carrying the bellows head downward until stopped by the reset/ adjustment screw. The sensor will again be in the venting configuration as shown.

On Manual Reset models, the automatic reset/differential adjustment screw will be replaced with a spring loaded plunger as shown in the inset. The reset plunger will allow the bellows to extend downward to a point the sleeve cannot reach regardless of how much the Process Pressure drops. For this reason, the plunger must be depressed (while pressure is supplied to the CONTROL port) to raise the bellows head enough to allow the sleeve to contact the bellows head O-ring. With this accomplished, the sensor will reset as previously described.

NOTE: Depressing the plunger without a CONTROL PRESSURE present will NOT reset the sensor.

Figure 2
84374-A1 Shown
(Inlet port rotated 90° from true position)

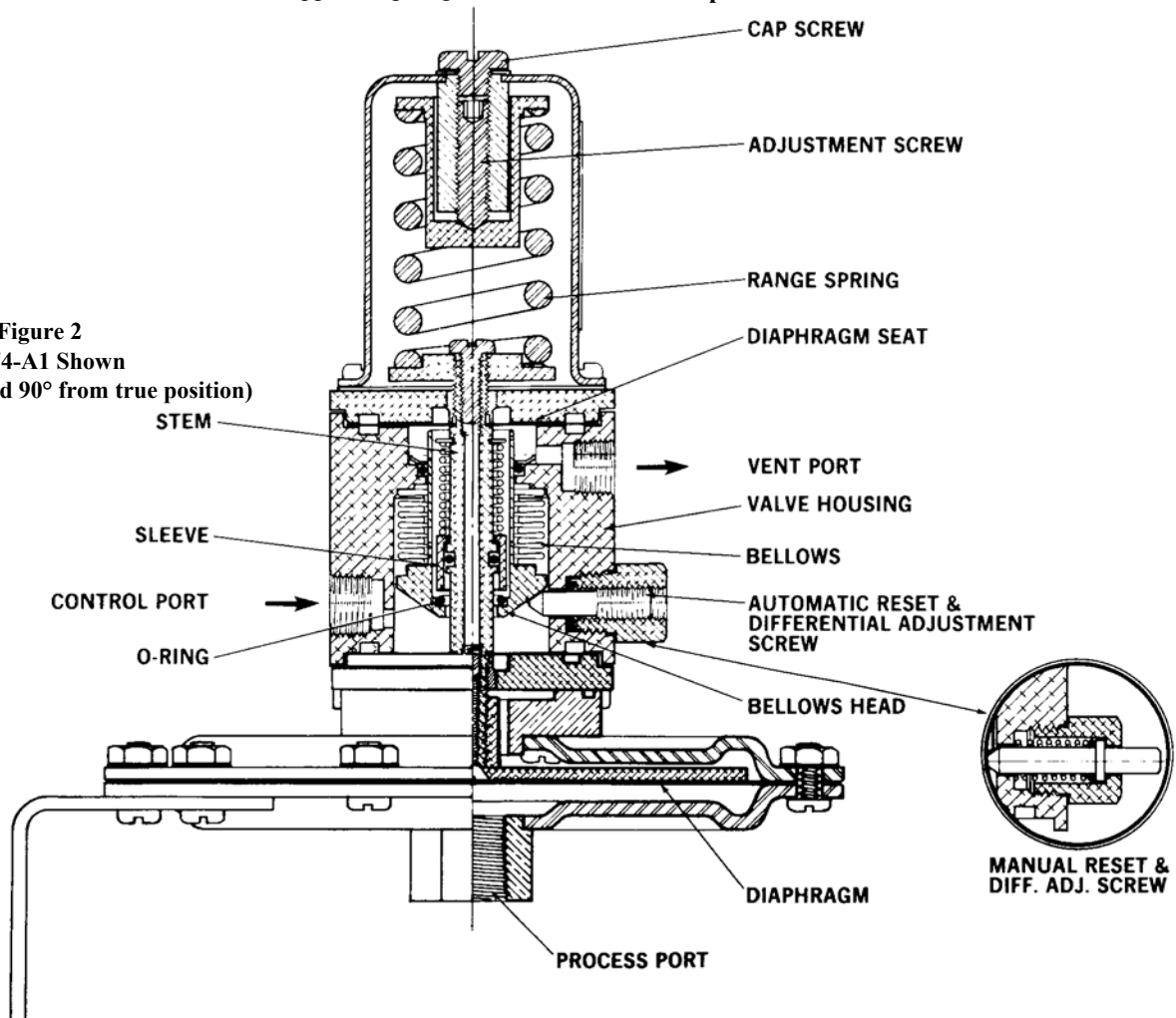

MAINTENANCE - See Figure 4

WARNING: USE CARE WHEN DISASSEMBLING, SPRING FORCES PRESENT.

Caution: Do not subject O-rings, gasket, or diaphragms to cleaning fluid, acetone, or any halogenated hydrocarbons such as degrease liquids, etc. Clean only with a soft, dry cloth. Metal parts can be cleaned with a suitable solvent, then dried thoroughly before reassembly.

Pressure Assembly

Remove the three screws (detail 35) holding the sensor to its mounting bracket (detail 34). Remove the sensor. Remove the remaining seven screws (detail 37) securing the housing together. Remove the lower housing plate (detail 38) and then the exposed diaphragm, (detail 43). Remove the retaining screw (detail 39) and the diaphragm shoe (detail 42). Remove the four screws (detail 41) securing the upper housing and remove the upper housing (detail 33). The O-ring (detail 32) should come off with the housing. If not, remove it. Replace the defective parts and reassemble* in reverse sequence.

Bushing

To replace the bushing O-ring (detail 24) remove the bushing (detail 25) and replace the defective O-ring. Reassemble* and replace in valve housing (detail 15). Recalibrate if sensor is an automatic reset model.

Spring Housing Assembly

Remove the cap screw (detail 1) and washer (detail 2) and turn the adjustment screw (detail 5) counterclockwise to bring the range spring (detail 6) to its free length. Remove the four screws (detail 11) securing the spring housing (detail 3) and remove the housing. Remove the range spring, spring seat locking screw and spring seat (detail 4). Reassemble* in reverse sequence.

Valve Housing Assembly

Remove the pressure assembly, spring housing assembly and bushing as described above. Proceed as described under applicable instructions for either the direct-acting or reverse-acting sensor.

DIRECT-ACTING

Remove the four screws (detail 31) securing the flange that was under the pressure assembly. Remove the flange (detail 30). Prevent the spring seat (detail 9) from rotating and remove the exposed diaphragm clamp. Remove the exposed diaphragm (detail 14). Pull the stem (detail 21) from the valve housing by removing it as an assembly with the remaining flange (detail 13). (The spring seat will remain intact).

Prevent the spring seat from rotating and remove the locking screw (detail 8). Prevent the stem from rotating and remove the spring seat. Remove the flange from the stem assembly. Proceed with the instructions under "DIRECT AND REVERSE ACTING."

REVERSE-ACTING

Remove the four screws (detail 31) securing the flange that was under the pressure assembly. Remove the flange (detail 30).

Prevent the spring seat (detail 9) from rotating and remove the locking screw (detail 8). Prevent the exposed diaphragm clamp (detail 10) from rotating and remove the spring seat. Remove the remaining flange (detail 13).

Still holding the same diaphragm clamp, remove the newly exposed clamp and diaphragm. Pull the stem (detail 21) from the valve housing with the remaining diaphragm and clamp intact. Proceed with the instructions under "DIRECT AND REVERSE ACTING."

DIRECT AND REVERSE ACTING

Remove the remaining diaphragm and clamp. Remove the retaining ring (detail 16) while compressing and holding the spring (detail 19) on the stem. Remove the spring and sleeve (detail 23) to expose the O-ring (detail 20) for replacement. Reassemble* the stem assembly in reverse sequence.

To replace the O-ring (detail 18) in the valve housing, remove the retaining ring (detail 17) and the O-ring directly beneath it. Insert the new O-ring and replace the retaining ring.

To replace the O-ring (detail 22) located in the bellows head, remove the O-ring with a knife or some other sharp pointed instrument. Carefully remove any residue where the O-ring was removed and clean the seating area with a suitable solvent. Dry thoroughly and place a few drops of liquid Viton (Pelmar Laboratories PLV-2000 or equivalent) on the seating area. Clean and place the new O-ring on the seating area. Allow bond to cure for one or more hours.

With all O-rings, diaphragms, gaskets and defective parts replaced, reassemble* as follows: (refer to Figure 3).

NOTE: For Direct-Acting models hold valve housing as in Figure 3; for Reverse-Acting models invert housing.

Be certain that all parts are clean and free of foreign matter. On automatic reset models, turn the differential adjustment screw counterclockwise several turns. Replace the stem, diaphragms and diaphragm clamps.* Hand tighten the clamps and then while holding each clamp with a wrench, tighten 1/4 turn more.

Replace both flanges and secure with at least two screws (placed diagonally from each other). On the flange where the pressure assembly mounts, replace all four screws* (securing the flange) and snug all screws down.

Replace the spring seat and its locking screw. DO NOT TIGHTEN YET. Turn the differential adjustment screw clockwise until it becomes difficult to turn; DO NOT TIGHTEN. On manual reset models, depress the reset plunger. Then apply an approximate one pound force at "P" (See Fig. 3) and turn the spring seat to obtain dimension "A." Tighten the locking screw* snug and turn the differential adjustment screw counterclockwise 3/4 turn.

Remove the two screws securing the flange under the spring seat and replace the spring and spring tower assembly. Then replace all four screws* to secure the flange and spring tower.

Reassemble the remainder in reverse sequence and recalibrate.

**NOTE - The following should be fitted using Loctite Sealant "H," or equivalent, applied before reassembly: Spring Seat Screw (detail 8), Diaphragm Clamps, Spring Housing Screws (detail 11), Bushing, Flange Screws (detail 31), Housing Plate Screws (detail 41), Diaphragm Shoe Screw (detail 39) and Cover Screws (details 35 and 37).*

FIELD REVERSAL

To change the sensor from direct to reverse acting or vice versa, disassemble down to valve housing assembly. Remove the locking screw (detail 8) and spring seat (detail 9). With a long allen wrench, remove the set screw (detail 33) from inside the stem.

Remove the flanges. Invert the valve housing assembly and re-install the set screw all the way to the end of the stem. Replace the flanges and secure with screws. Reassemble the pressure assembly to the valve housing. DO NOT replace the spring seat or screw at this time. Apply a 5 psi process pressure to the HP process port. Apply a 30 psi pressure to the control port. Insert the allen wrench at point "P." Apply approximately a one pound downward force on the allen wrench and slowly turn the set screw clockwise until the sensor vents the control pressure on direct-acting models. Then turn one-half turn further. On reverse acting models, first turn the set screw clockwise until the venting stops and then turn counterclockwise until the sensor vents once more. Then turn one-half turn further. Apply Loctite to set screw.

Complete the re-assembly per previous instructions and recalibrate the sensor.

ADJUSTMENTS

Setpoint

1. Remove cap screw.
2. Apply operating control pressure to inlet port through a .8 mm (.032") diameter or smaller orifice. Control pressure and orifice size must be the same as that used during normal operation.

3. Apply process pressure at desired setpoint to the process port.
4. Insert a 1/8" hex wrench into the adjustment screw and turn screw counterclockwise (clockwise for reverse-acting units) until the valve snaps open and sensor vents. If the valve is already open, turn the screw clockwise (counterclockwise for reverse-acting units) until the valve closes, then reverse direction and turn screw until valve snaps open and vents.
5. Check operation and trim as necessary.
6. Replace the cap screw.

Differential (Applicable to Auto Reset versions only)

CAUTION: Sensor will not vent if differential adjustment screw is turned clockwise to its maximum insertion into the valve housing. Do not set differential below minimum recommended value as shown in graphs.

1. Apply operating control pressure to inlet port through a .8 mm (.032") diameter or smaller orifice. Control pressure and orifice size must be the same as that used during normal operation.
2. Cycle measured pressure at the process port and adjust the differential adjustment screw until desired differential is obtained. Differential is increased by turning the screw counterclockwise.

Figure 3

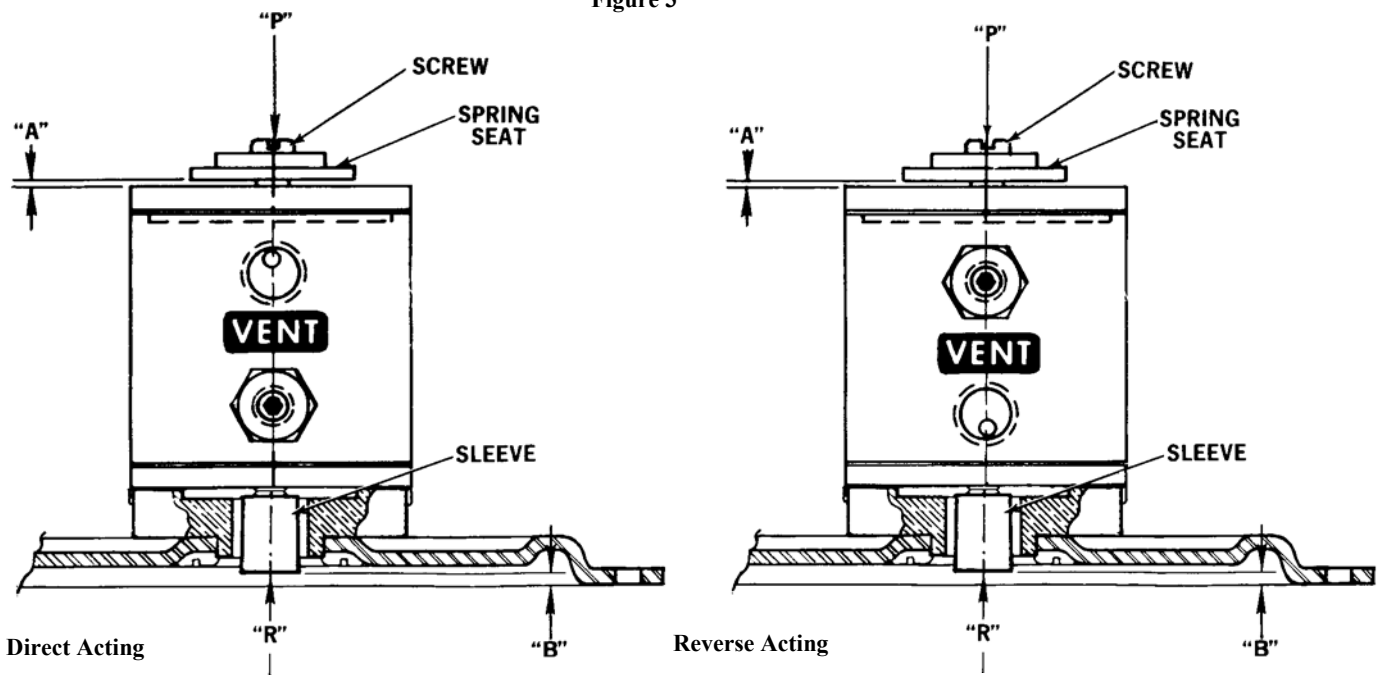

Table 3

Model No.	Dim. "A," mm (In.)	Dim. "B," mm (In.)
84374-A, C	1.65 (.065)	2.79 (.110)
84374-B	.51 (.020)	2.0 (.078)

PARTS LIST

Det. No.	No. Req'd	Description	Prod. Part No.
1	1	Cap Screw	33718-G0509
2	1	Washer	24425-A1
3	1	Spring Housing	84366-A1
4	1	Spring Seat	24557-B1
5	1	Adjustment Screw	24558-A2
6	1	Range Spring	See Tab.
7	1	Name Plate	See Tab.
8	1	Screw	33713-G1109
9	1	Spring Seat	33968-A2
10	2	Diaphragm Clamp	33969-A1
11	4	Screw	33713-G1309
*12	1	Gasket	33971-A1
13	1	Flange	33966-B1
*14	2	Diaphragm	33972-A1
15	1	Valve Housing	84364-A1
*16	1	Retaining Ring	36605-Q9
*17	1	Retaining Ring (Incl. in Det. 15)	36605-B2
*18	1	O-Ring (Incl. in Det. 15)	36240-V0016
19	1	Spring	33975-A1
*20	1	O-Ring	36240-V0010
21	1	Stem	33973-A2
*22	1	O-Ring (Incl. in Det. 15)	36243-V0012
23	1	Sleeve	33974-A2
*24	1	O-Ring	36240-V0007
25	1	Bushing	See Tab.
26	1	Differential Adjustment Screw	33963-A1
27	1	Reset Plunger	33962-A2
28	1	Set Screw	Not Used
29	1	Spring	33965-A1
30	1	Flange	33966-B2
31	4	Screw	33713-K1309
*†32	1	O-Ring	36240-C0030
33	1	Diaphragm Housing	83898-B1
34	1	Bracket	33603-C1
35	3	Screw	33713-G1309
36	10	Nut	36603-A22
37	7	Screw	33713-G1109
38	1	Diaphragm Housing	83897-B1
39	1	Screw	Not Used
40	1	Sleeve	33990-A1
41	4	Screw	33713-G1309
42	1	Diaphragm Shoe	27462-B1
†43	1	Diaphragm	30873-A1

NOTE: For kit containing all O-Rings, gaskets, diaphragms and retaining rings to service one valve body, order Repair Kit No. 82665-G1. Kit contains details marked *

For kit containing large O-Ring and diaphragm to service one Pressure Assembly, order Repair Kit No. 82665-M1. This kit contains details marked †.

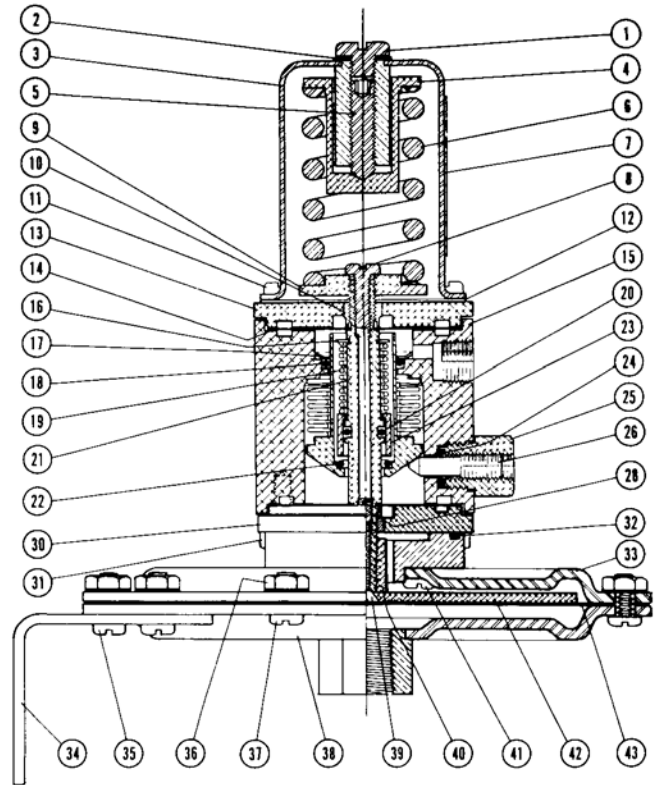
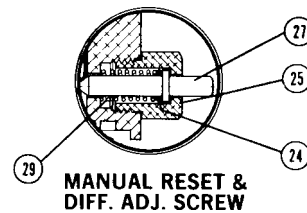

Figure 4
84374-A1 Shown



MANUAL RESET & DIFF. ADJ. SCREW

TABULATION

Model No.	Det. 6	Det. 7	Det. 25
84374-A1	33980-H1	33970-B61	33964-A2
84374-A2	33980-G1	33970-B62	33964-A2
84374-B1	33980-H1	33970-B63	33964-A2
84374-B2	33980-G1	33970-B64	33964-A2
84374-C1	33980-H1	33970-B65	33964-B2
84374-C2	33980-G1	33970-B66	33964-B2

Robertshaw

U.S.A. and CANADA

**Robertshaw Industrial Products Division
1602 Mustang Drive
Maryville, Tennessee 37801
Phone: (865) 981-3100 Fax: (865) 981-3168
<http://www.robertshawindustrial.com>**

Exports

**Invensys Appliance Controls
1701 Byrd Avenue
P.O. Box 26544
Richmond, Virginia 23261-6544
Phone: (804) 756-6500 Fax: (804) 756-6561**