



INDUSTRIAL PRODUCTS DIVISION

**Pressure Sensor
 No. 84373-Series**

GENERAL DESCRIPTION

The patented* No. 84373-Series Pressure Sensor contains a weather-proof, snap-acting valve operated by pressure variation around the integral sensing element. Depending upon model used, it vents or blocks a pneumatic signal when the setpoint is reached and is available with either automatic or manual reset. The sensor has adjustable differential (auto reset versions only) and setpoint, provision for piped vent operation, and is field reversible. Setpoint is virtually unaffected by control pressure change or, in the case of piped vent versions, vent backpressure change. In the auto reset versions, reset differential can be changed without shifting setpoint.

For correct operation, control pressure must be provided thru a .81 mm (.032") diameter or smaller orifice.

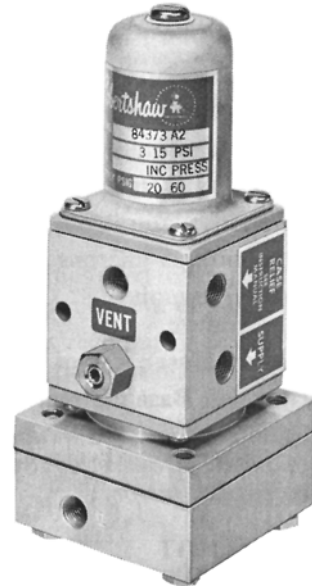

*Patent 3,986,524

MODELS AVAILABLE

84373-

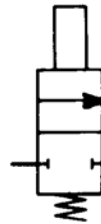

84373-A, C Series
 Vents on Increase
 (Direct-Acting)



84373-B Series
 Closes Vent on Increase
 (Reverse-Acting)

J.I.C. Symbols

TABLE 1

SUFFIX	DESCRIPTION	RESET
A	Direct Acting - Vents on Increase	Auto
B	Reverse Acting - Closes Vent on Increase	Auto
C	Direct Acting - Vents on Increase	Manual

TABLE 2

SUFFIX	SETPOINT RANGE - bar (psi)
1	.07 to .34 (1 to 5)
2	.2 to 1.0 (3 to 15)

ORDERING INFORMATION

Specify:

1. Model
2. Control Pressure-If not specified, sensor is set using 2.1 bar (30 psi).
3. Setpoint-If not specified, set at minimum.
4. Differential (Automatic Reset models only)-If not specified, set at standard.
5. Tagging Information.

See Page 2 for SPECIFICATIONS

SPECIFICATIONS

- Valve Housing, Housing Plate and Cover: Anodized Aluminum Alloy
- Spring Housing: 316 Stainless Steel
- Springs: Stainless Steel
- O-Rings: Fluorocarbon and Neoprene
- Diaphragms and Gasket: Buna-N on Nylon
- Control Pressure: 1.4 to 4.1 bar (20 to 60 psi)
- Maximum Control Pressure: 5.2 bar (75 psi)
- Maximum Ambient Temperature: 71° C. (160° F.)
- Repeatability: ±1% of setpoint
- Approximate Shipping Weight: 1.0 Kg. (2-1/4 lb.)
- Control Medium: Air, Natural Gas, Nitrogen, CO₂
- Filtration: (Minimum): 25 microns
- Moisture (Pressure Dewpoint): 8° C. (15° F.) less than ambient temperature.
- Oil Content (Natural Base): 5 ppm
- Oil Content (Synthetic Base): 0 ppm

NOTE: These are suggested minimums for control medium quality. For operation under more adverse conditions, consult factory.

CAUTION: DO NOT EXCEED MAXIMUM TEMPERATURE/PRESSURE RATINGS.

Process and Reset Pressure Characteristics:

Model No.	Maximum Process Pressure, bar (psi)	Standard Reset Differential bar (psi)	Minimum Process Pressure Drop to Manually Reset, bar (psi)
84373-A1	5.2 (75)	.049 (0.7)	
84373-A2	5.2 (75)	.10 (1.5)	
84373-B1	5.2 (75)	.049 (0.7)	
84373-B2	5.2 (75)	.10 (1.5)	
84373-C1	5.2 (75)		.021 (.3)
84373-C2	5.2 (75)		.042 (.6)

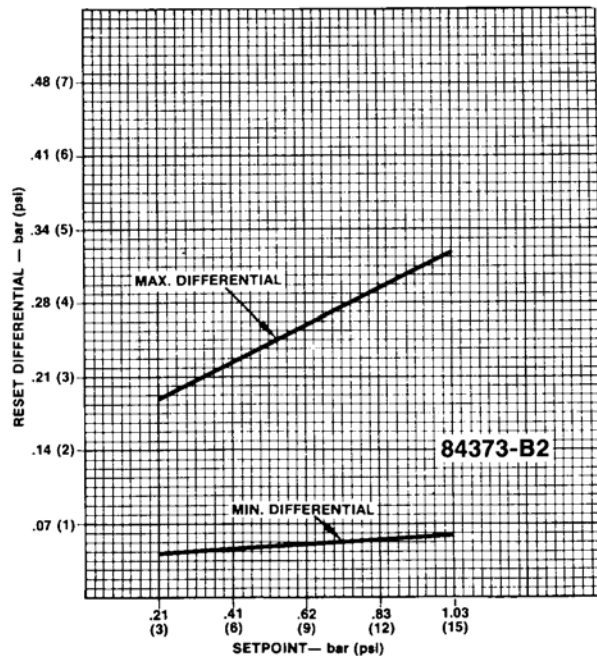
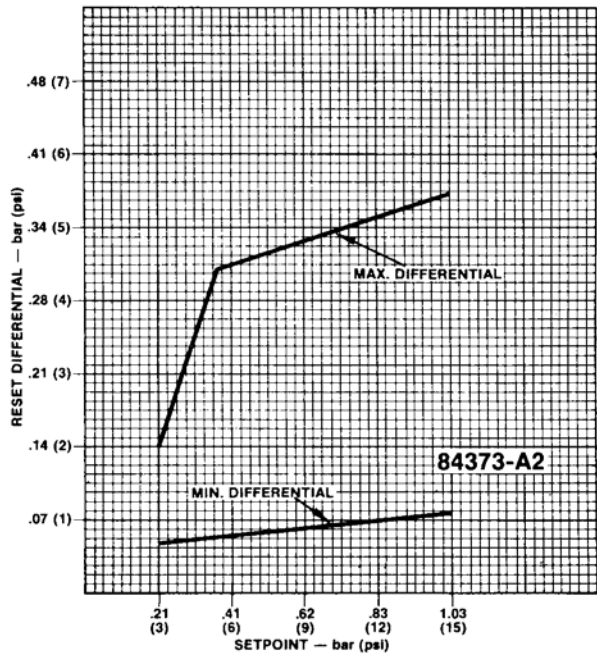

Reset Differential Range: See graph corresponding to instrument model numbers.

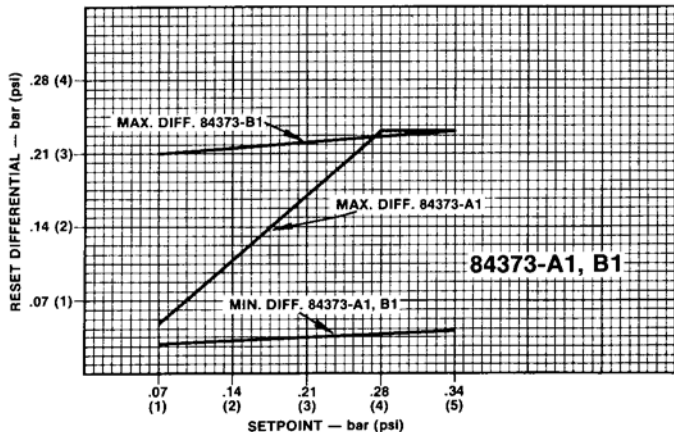

INSTALLATION MOUNTING:

The No. 84373-Series Pressure Sensor may be mounted in any position, although vertical (upright) is recommended. It should be securely mounted on the panel or other suitable surface to prevent excessive vibration using the mounting bracket and/or the two 5.5 mm (7/32") diameter holes in the housing assembly.

If the measured variable is a liquid, consideration should be given to the liquid level. Since an error in calibration could be caused by weight of a body of liquid acting on the measuring assembly, it may be necessary to adjust calibration to compensate for the constant weight (See Adjustments).

If the sensor is out of doors or in any way exposed to water during cleaning, etc., it should be mounted in a position that will prevent water entry into the valve or spring housings. Water trapped in the housing will impair operation and could freeze during winter months. Vent openings should have fittings installed turned down. The 1/8"-27 NPT vent connection can be used for piped vent operation if gas is used.

If the sensor is used with a liquid process pressure, entrapped air in tubing connected to the measuring assembly should be vented. This can be accomplished by bleeding the connection at the sensing element.

CONNECTIONS:

The sensor has four 1/8"-27 NPT connections - one for control pressure, one for vent pressure, one for case relief pressure and one for process pressure.

CAUTION: Do not pipe or plug case relief connection. The vent pressure connection from the sensor cannot be used as a supply or control source for any other equipment. Vent backpressure should be held to as low a level as possible.

Control port pressure must be provided through a .8 mm (.032") diameter or smaller orifice using 6 mm (1/4") or 9.5 mm (3/8") O.D. tubing. Using excessive lengths or other than the specified tubing is not recommended.

Tubing and fittings used to connect the sensor must be free of chips, dirt, moisture or other foreign matter.

On fittings, it is recommended that a non-hardening, "anti-seize" type thread compound be applied to the threads in moderate amount. The first thread should then be wiped of excess to avoid compound being deposited inside the relay. Thread sealing tape is not recommended.

DIMENSIONS - Millimeters (Inches)

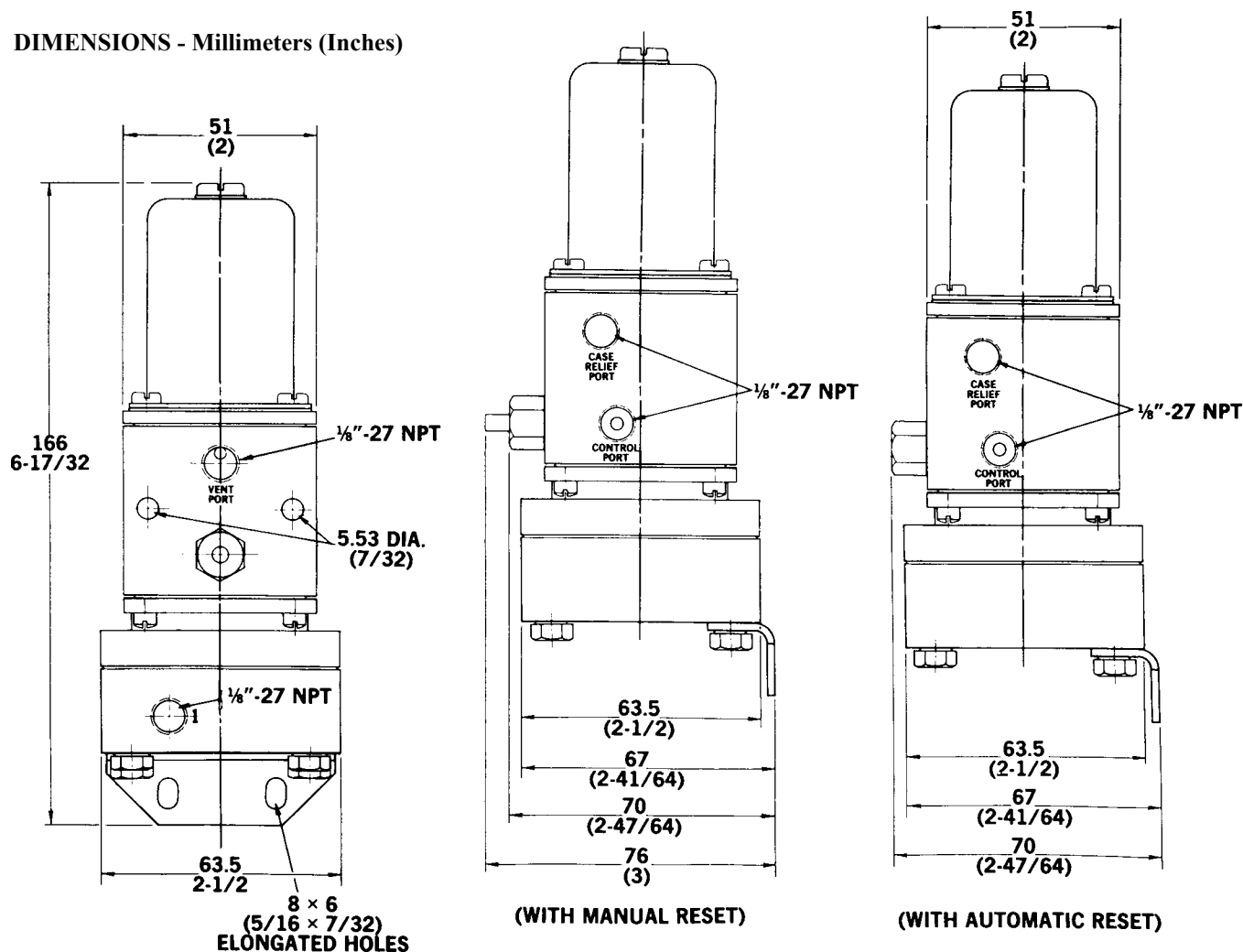

Figure 1
Direct Acting Shown

OPERATION - See Figure 2

The direct-acting sensor in Figure 2 is shown in the venting configuration. Pressure entering the CONTROL port flows past the O-ring, around the stem and sleeve and out the VENT port. Downward travel of the bellows head is limited by the reset screw.

Decreasing the process pressure to the reset valve causes the stem and sleeve to travel downward until the sleeve contacts the O-ring, causing the sensor to close. Pressure entering the CONTROL port builds up on the outside of the bellows causing it to move upward, carrying the sleeve with it, until the tubular portion of the bellows head contacts the upper diaphragm seat. The sensor is now reset and the O-ring has moved to a higher elevation.

A rise in process pressure causes the stem to move upward compressing the range spring. When the stem

moves upward enough to cause the sleeve to lift off the O-ring seat, some of the pressure outside the bellows flows to the inside. This pressure transfer causes the bellows to extend until the bellows head contacts the reset screw. This returns the sensor to the venting position.

On the manual reset models, the automatic reset screw is replaced with a spring-loaded plunger which permits the bellows head to extend to an elevation that cannot be reached by the sleeve no matter how much the process pressure is decreased. Therefore, the plunger must be manually depressed while restricted pressure is supplied to the CONTROL port. This forces the O-ring to contact the sleeve and reset as previously described. Depressing the plunger without pressure supplied to the CONTROL port will NOT reset the sensor.

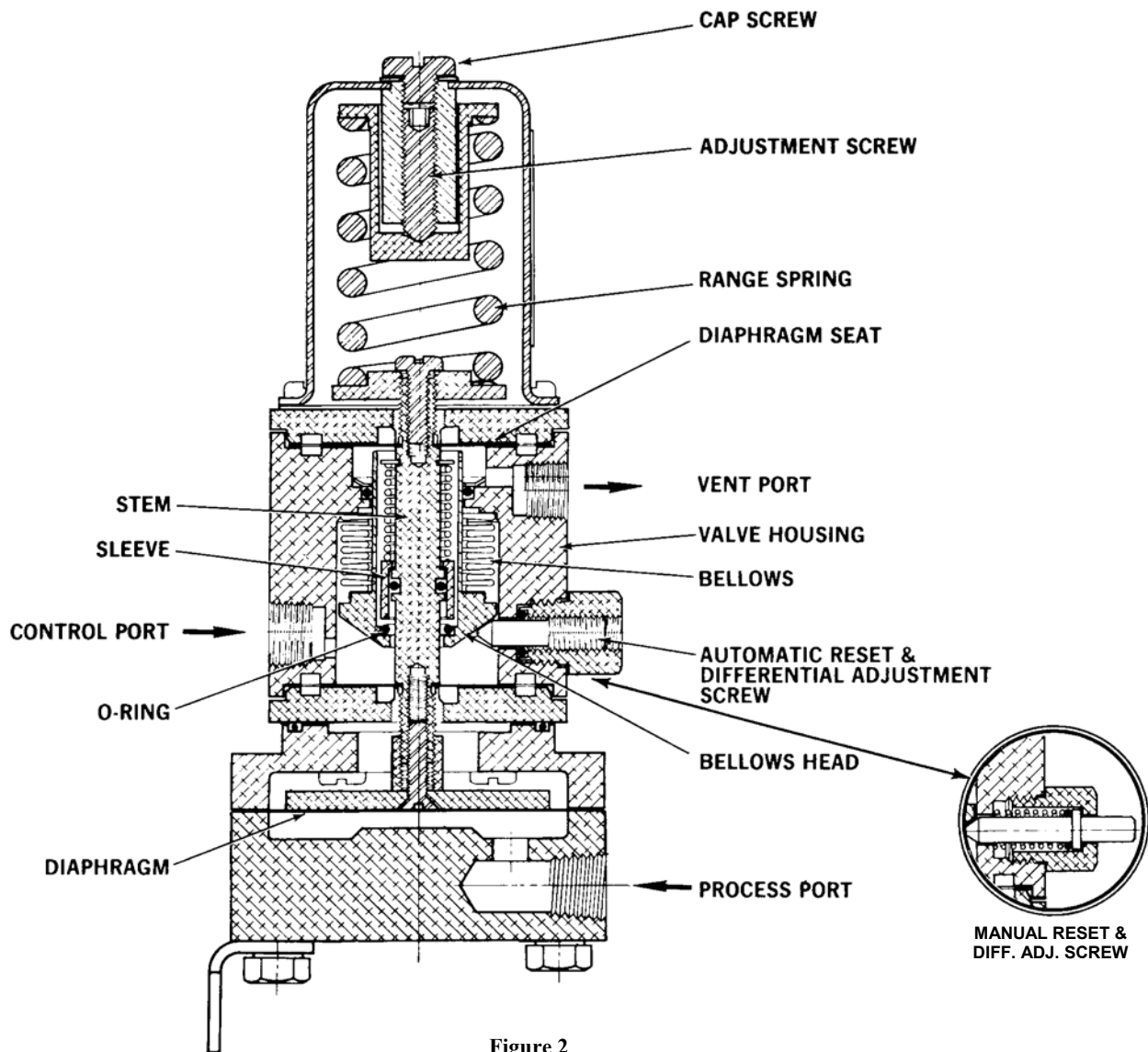

Figure 2
84373-A1 Shown
(Inlet port rotated 90° from true position)

MAINTENANCE - See Figure 4

WARNING: USE CARE WHEN DISASSEMBLING, SPRING FORCES PRESENT.

Caution: Do not subject O-rings, gasket, or diaphragms to cleaning fluid, acetone, or any halogenated hydrocarbons such as degrease liquids, etc. Clean only with a soft, dry cloth. Metal parts can be cleaned with a suitable solvent, then dried thoroughly before reassembly.

Pressure Assembly, Diaphragm and O-Ring

Remove four screws (detail 37), bracket and cover. Remove the diaphragm (detail 36). Remove screw (detail 34) and diaphragm shoe. Remove four screws (detail 32) and housing plate. Remove O-Ring (detail 28). Replace defective parts and reassemble*.

Bushing

To replace bushing O-ring (detail 26), remove bushing and replace defective O-ring. Reassemble* unit and replace in housing assembly. Recalibrate differential if unit is an automatic reset model.

Housing Assembly and Stem

Remove cap screw and turn adjustment screw (detail 5) counterclockwise to bring the range spring to free length. Remove four screws (detail 11), spring housing, spring seat (detail 4), range spring and gasket. Remove pressure assembly O-ring as described above. Remove stop.

As applicable, proceed with Direct or Reverse Acting instructions below.

Direct Acting

Remove four screws (detail 31) and flange (detail 30).

Prevent spring seat (detail 9) from rotating and remove exposed diaphragm clamp. Remove stem by pulling flange (detail 13) from valve housing.

To replace O-ring (detail 20) on stem, prevent spring seat (detail 9) from rotating and remove screw (detail 8). Prevent stem from rotating and remove spring seat (detail 9) and flange. Proceed with instructions designated Direct and Reverse Acting below.

Reverse Acting

Remove four screws (detail 31) and flange (detail 30).

Preventing the exposed diaphragm clamp from rotating, remove screw (detail 8) and spring seat (detail 9). Remove flange. Prevent diaphragm clamp that was exposed first from rotating, and remove other diaphragm clamp. Remove exposed diaphragm. Remove stem by pulling it from valve housing.

Proceed with instructions designated Direct and Reverse Acting below.

Direct- and Reverse-Acting

Remove remaining diaphragm clamp and diaphragm. Remove retaining ring (detail 17), spring (detail 19) and sleeve. Remove defective O-ring (detail 20) and replace. Reassemble sleeve, spring (detail 19) and retaining ring (detail 17).

To replace O-ring (detail 21) in valve housing, remove retaining ring (detail 18) and defective O-ring (detail 21). Replace O-ring, then retaining ring.

To replace O-ring (detail 22) which seats against the sleeve, remove the defective O-ring with a knife or other sharp-pointed tool. Carefully remove any residue and clean area from where O-ring was removed with a suitable solvent. Dry thoroughly. Place a few drops of liquid Viton (Pelmor Laboratories' PLV-2000 or equivalent) on the seating area just cleaned. Clean and bond replacement O-ring to its seating area. Allow to cure for one or more hours.

With all O-rings, diaphragms, gaskets and defective parts replaced, reassemble as follows:

On models with automatic reset, turn differential adjustment screw counterclockwise several turns. Replace stem, diaphragms, and diaphragm clamps.* Tighten clamps hand tight. While holding each clamp with a wrench, tighten approximately 1 /4 turn more. Reassemble* remaining parts as shown in figure 3.

On models with automatic reset, carefully turn the differential adjustment screw clockwise until it just begins to bind and become difficult to turn - do not over-turn. On models with manual reset, depress the reset plunger while obtaining the following dimensions - see figure 3.

On Direct Acting sensors apply approximately one pound force (4.5 N) by finger at point "P" - on Reverse Acting sensors use the same procedure as described here for the Direct Acting except the valve housing is to be inverted from that shown in figure 3 and one pound force (4.5 N) to be applied at point "R."

Turn spring seat to obtain dimension "A" - see Table 3. Lock spring seat in place with screw*.

With a gage in place to hold dimension "A," adjust stop to dimensions "B" -- see Table 3. Lock stop and diaphragm shoe in place with screw* (detail 34) - see figure 4.

Release reset plunger on manual reset models and turn differential adjustment screw counterclockwise approximately 3/4 turn on auto reset models.

Reassemble* remaining parts and recalibrate sensor.

**NOTE: The following should be fitted using Loctite Sealant "H" or equivalent applied before assembly: Threads on screw (detail 8), Diaphragm clamps, Spring Housing screws (detail 11), Bushing, Flange screws (detail 31), Housing Plate screws (detail 32), Diaphragm Shoe screw (detail 34) and Cover screws (detail 37).*

FIELD REVERSAL

To change the sensor from direct to reverse acting or vice versa, remove spring seat (detail 9) and stop from stem. Remove both flanges from valve housing. Rotate valve housing 180 degrees and reassemble per Housing Assembly and Stem Maintenance instructions above. Recalibrate sensor when assembled.

ADJUSTMENTS SETPOINT

1. Remove cap screw.
2. Apply operating control pressure to inlet port through a .8 mm (.032") diameter or smaller orifice. Control pressure and orifice size must be the same as that used during normal operation.
3. Apply process pressure at desired setpoint to the process port.
4. Insert a 1/8" hex wrench into the adjustment screw and turn screw counterclockwise (clockwise for reverse-acting units) until the valve snaps open and sensor vents. If the valve is already open, turn the screw clockwise (counterclockwise for reverse-acting units) until the valve closes, then reverse direction and turn screw until valve snaps open and vents.
5. Check operation and trim as necessary.
6. Replace the cap screw.

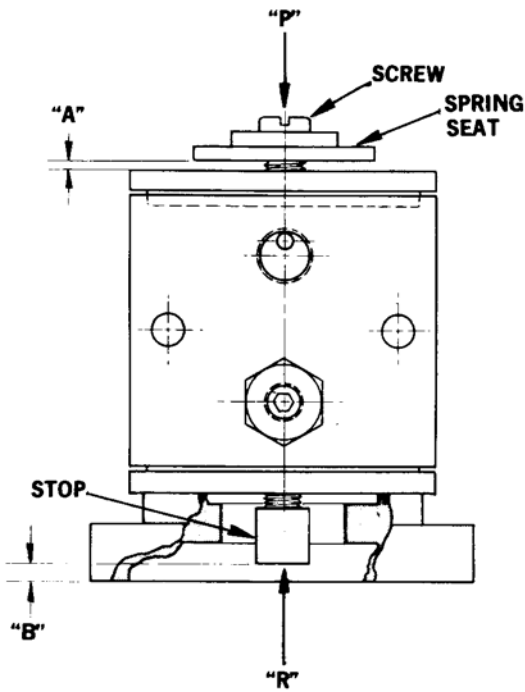

Figure 3
(Direct Acting Shown)

DIFFERENTIAL (Applicable to Auto Reset versions only)

CAUTION: Sensor will not vent if differential adjustment screw is turned clockwise to its maximum insertion into the valve housing. Do not set differential below minimum recommended value as shown in graphs.

1. Apply operating control pressure to inlet port through a .8 mm (.032") diameter or smaller orifice. Control pressure and orifice size must be the same as that used during normal operation.
2. Cycle measured pressure at the process port and adjust the differential adjustment screw until desired differential is obtained. Differential is increased by turning the screw counterclockwise.

Table 3

MODEL NO.	DIM. "A", mm (In.)	DIM. "B", mm (In.)
84373-A, C	1.65 (.065)	3.2 (.125)
84373-B	.51 (.020)	2.2 (.085)

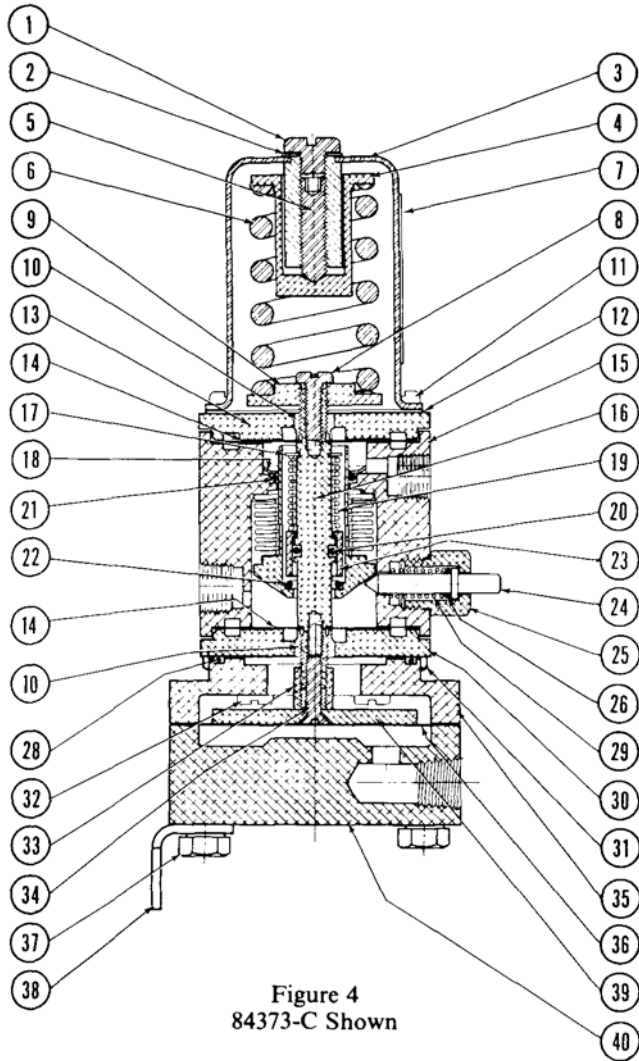

Figure 4
84373-C Shown

DET. NO.	NO. REQ'D	DESCRIPTION	PART NO.
1	1	Cap Screw	33718-G0509
2	1	Washer	24425-A1
3	1	Spring Housing	84366-A1
4	1	Spring Seat	24557-B1
5	1	Adjustment Screw	24558-A2
6	1	Range Spring	See Tabulation
7	1	Name Plate	See Tabulation
8	1	Screw	33713-G1109
9	1	Spring Seat	33968-A2
10	2	Diaphragm Clamp	33969-A1
11	4	Screw	33713-G1309
* 12	1	Gasket	33971-A1
13	1	Flange	33966-B1
* 14	2	Diaphragm	33972-A1
15	1	Valve Housing	84364-A1
16	1	Stem	33973-A1
* 17	1	Retaining Ring	36605-Q9
* 18	1	Retaining Ring - Included in Detail 15	36605-B2
19	1	Spring	33975-A1
* 20	1	"O"-Ring	36240-V0010
* 21	1	"O"-Ring -Included in Detail 15	36240-V0016
* 22	1	Quad Ring -Included in Detail 15	36243-V0012
23	1	Sleeve	33974-A2
24	1	Reset Plunger	See Tabulation
25	1	Bushing	See Tabulation
* 26	1	"O"-Ring	36240-V0007
27	1	Differential Adjustment Screw (Not shown)	See Tabulation
†* 28	1	"O"-Ring	36240-C0030
29	1	Spring	See Tabulation
30	1	Flange	33966-B2
31	4	Screw	33713-K1309
32	4	Screw	33713-G1309
33	1	Stop	33990-A1
34	1	Screw	33713-L1509
35	1	Housing Plate	33991-A1
†36	1	Diaphragm	24611-A1
37	4	Screw	33718-T2410
38	1	Bracket	24637-A4
39	1	Diaphragm Shoe	33992-A
40	1	Cover	33993-A1

NOTE:

For complete kit containing "O"-Rings, gaskets, diaphragms and retaining rings to service one valve body, order Repair Kit No. 82665-G1. Kit includes details marked *.

For kit containing "O"-ring, and diaphragm to service one pressure assembly, order Repair Kit No. 82665-L1. This kit contains details marked †.

TABULATION

MODEL NO.	DET. 6	DET. 7	DET. 24	DET. 25	DET. 27	DET. 29
84373-A1	33980-A1	33970-B55		33964-A2	33963-A1	
84373-A2	33980-G1	33970-B56		33964-A2	33963-A1	
84373-B1	33980-A1	33970-B57		33964-A2	33963-A1	
84373-B2	33980-G1	33970-B58		33964-A2	33963-A1	
84373-C1	33980-A1	33970-B59	33962-A2	33964-B2		33965-A1
84373-C2	33980-G1	33970-B60	33962-A2	33964-B2		33965-A1

Robertshaw

U.S.A. and CANADA

**Robertshaw Industrial Products Division
1602 Mustang Drive
Maryville, Tennessee 37801
Phone: (865) 981-3100 Fax: (865) 981-3168
<http://www.robertshawindustrial.com>**

Exports

**Invensys Appliance Controls
1701 Byrd Avenue
P.O. Box 26544
Richmond, Virginia 23261-6544
Phone: (804) 756-6500 Fax: (804) 756-6561**