



INDUSTRIAL PRODUCTS DIVISION

# Ratio Relay

## Adjustable Bias

### CR-101-Series A & B

#### GENERAL DESCRIPTION

The Model CR-101 Series A and B Ratio Relays are proportioning units designed for use in industrial pneumatic control systems where the application requires amplifying or reducing the volume of control air to the final control devices. The relay components are made of steel and aluminum and the diaphragms are Buna-N on nylon.

#### SPECIFICATIONS

##### DESIGN DATA

##### Input-Output Ratios:

| Amplifying | Reducing |
|------------|----------|
|            | 1.2:1    |
| 1:1.5      | 1.5:1    |
| 1:2        | 2:1      |
| 1:3        | 3:1      |
| 1:4        | 4:1      |
| 1:5        | 5:1      |
| 1:6        | 6:1      |

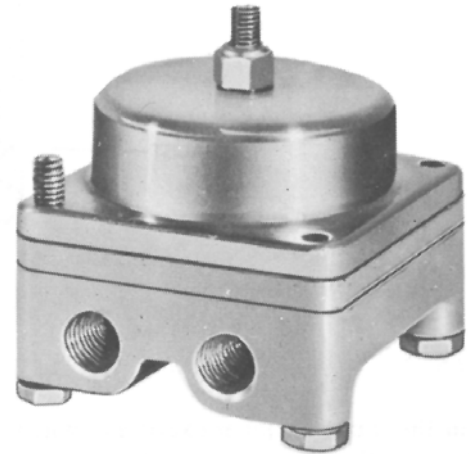

#### SPECIFICATIONS

##### DESIGN DATA

##### Input Pressure Range (P<sub>i</sub>):

25 psig (1.8 bar) maximum for amplifying  
90 psig (6.3 bar) maximum for reducing

##### Supply Pressure:

60 psig (4.2 bar) maximum (should be at least 10 psig [0.7 bar] greater than output pressure)

##### Output Pressure: ..... 50 psig (3.5 bar) maximum

##### Action: ..... Proportional

##### Ambient Temperature Limits: ... -40 to 180° F. (-40 to 82°)

##### Biasing Adjustment (F<sub>s</sub>): ..... ± 18 psig (1.2 bar)

##### Connections: ..... 1/4" female NPT. (Exhaust connection is 1/16" female NPT.)

##### Weight: ..... 1.2 lbs. (0.54 Kg)

**Air Consumption: Maximum** ..... 3.0 SCFH

##### For Maximum Flow:

*Supply output capacity* ..... 3.0 SCFM nominal

*Exhaust output capacity* ..... 5.0 SCFM nominal

#### ORDERING INFORMATION

Specify ratio of input to output.

#### PERFORMANCE DATA

**Ultimate Sensitivity:** ..... 0.1% of full range

**Supply Pressure Effect:** ..... Change in output pressure for a  
5 psig (0.35 bar) supply pressure change:  
Less than 1% of full range.

**Ambient Temperature Effect:** ..Change in output for a 75 F  
(24° C) change in ambient temperature:  
0.5% of full range.

| Amplifying Relays |       | Reducing Relays |       |
|-------------------|-------|-----------------|-------|
| Model No.         | Ratio | Model No.       | Ratio |
|                   |       | 81032-K2        | 1.2:1 |
| 81032-G6          | 1:1.5 | 81032-K1        | 1.5:1 |
| CR101-A2          | 1:2   | CR101-B2        | 2:1   |
| CR101-A3          | 1:3   | CR101-B3        | 3:1   |
| CR101-A4          | 1:4   | CR101-B4        | 4:1   |
| CR101-A5          | 1:5   | CR101-B5        | 5:1   |
| CR101-A6          | 1:6   | CR101-B6        | 6:1   |

## DIMENSIONS

This relay will operate properly when mounted in any position.

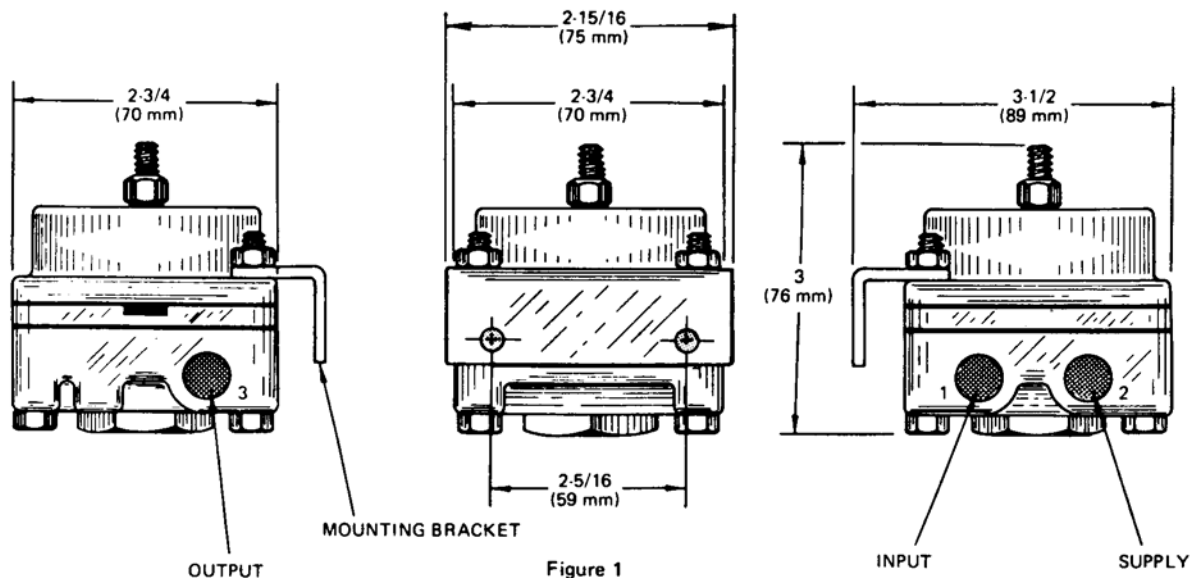

Figure 1

## OPERATION

The output pressure is proportional to the input pressure as the effective area of the input diaphragm is to the effective area of the output diaphragm when the biasing spring is adjusted to zero load. The relay is in a balanced position when the input pressure, plus the effect of the biasing spring, is balanced by the output pressure and both surfaces of the valve are seated. The illustration (Figure 2) shows a 1:6 amplifying relay.

When the input pressure is applied to the relay, air enters the input chamber and acts on the input diaphragm. As the input pressure increases, this pressure acts to move the center assembly downward, closing the exhaust portion of the valve and opening the lower portion of the valve. This permits supply air to enter the output chamber. This air pressure acts on the output diaphragm and also passes out of the output port.

Since the effective area of the input diaphragm, in this case, is six times as large as the effective area of the output diaphragm, the output pressure will have to be six times as great as the input pressure, and it will also have to balance the effect of the biasing spring in order to balance the unit. As the increasing output pressure approaches the balance point, the center assembly will begin to rise, permitting the valve to close, thereby throttling the flow of the supply air.

A further increase in the input pressure will cause the lower portion of the valve to open until the unit is again in balance. A decrease in the input pressure will permit the output pressure to raise the center assembly until the exhaust valve seat clears the upper surface of the valve, exhausting pressure until the unit is again in balance.

Turning the adjusting screw clockwise or counterclockwise, respectively, provides advanced or retarded biasing of the output pressure.

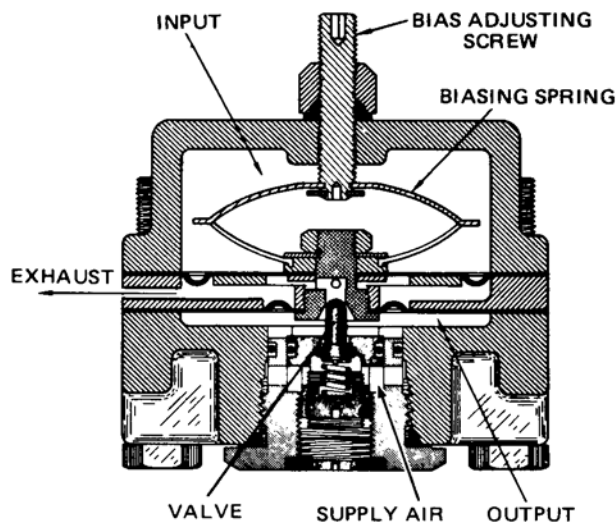

Figure 2

# Robertshaw

## U.S.A. and CANADA

Robertshaw Industrial Products Division  
1602 Mustang Drive  
Maryville, Tennessee 37801  
Phone: (865) 981-3100 Fax: (865) 981-3168  
<http://www.robertshawindustrial.com>

## Exports

Invensys Appliance Controls  
1701 Byrd Avenue  
P.O. Box 26544  
Richmond, Virginia 23261-6544  
Phone: (804) 756-6500 Fax: (804) 756-6561

Invensys®