

# INSTRUCTION MANUAL

Level-Lance™  
Model 5100

*Robertshaw*

Industrial Products Division

Robertshaw Industrial Products Division  
1602 Mustang Drive  
Maryville, TN 37801  
Telephone: (865) 981-3100 Fax: (865) 981-3168

Instruction Manual Number

**909GF275D**

**TABLE OF CONTENTS**

<b>SECTION</b>	<b>DESCRIPTION</b>	<b>PAGE</b>
<b>I</b>	<b>DESCRIPTION</b>	
1.1	General .....	1-1
1.2	Options .....	1-1
1.3	Model Identification .....	1-2
<b>II</b>	<b>SPECIFICATIONS</b>	
2.1	Electrical/Electronic .....	2-1
2.2	Environmental .....	2-1
2.3	Enclosure .....	2-1
2.4	Intrinsic Safety .....	2-2
<b>III</b>	<b>INSTALLATION</b>	
3.1	General .....	3-1
3.2	Probe Mounting .....	3-1
3.2.1	Horizontal Mounting .....	3-1
3.2.2	Vertical Mounting .....	3-1
3.3	Instrument Mounting .....	3-1
3.4	Electrical Connections .....	3-5
3.4.1	Interconnecting Cable .....	3-5
3.4.2	Relay Contact Terminals .....	3-5
<b>IV</b>	<b>OPERATION</b>	
4.1	Displays and Indicators .....	4-1
4.1.1	Status and Alarm Indicators .....	4-1
4.1.2	Switches and Controls .....	4-1
4.2	Selecting the Fail-Safe Mode .....	4-2
4.3	Selecting Time Delay .....	4-2
4.4	Selecting the Operating Mode .....	4-2
4.5	Calibration Procedure .....	4-3
4.6	Calibration Examples .....	4-4
4.6.1	High Level Alarm .....	4-4
4.6.1.1	Empty Vessel Calibration .....	4-5
4.6.1.2	Full Vessel Calibration .....	4-5
4.6.2	Low Level Alarm .....	4-5
4.6.2.1	Empty Vessel Calibration .....	4-5
4.6.2.2	Full Vessel Calibration .....	4-5
4.6.3	Single Point Calibration .....	4-6
4.6.3.1	High Level Sensing .....	4-6
4.6.3.2	Low Level Sensing .....	4-6
4.6.4	Adjustable Differential .....	4-6
4.6.4.1	High Point Calibration .....	4-6
4.6.4.2	Low Point Calibration .....	4-6

SECTION		PAGE
<b>V</b>	<b>TROUBLE SHOOTING</b>	
5.1	Trouble Shooting Chart .....	5-1
5.2	Probe Circuit Electrical Check .....	5-2
5.3	Built-In Diagnostics .....	5-3
5.3.1	Test (Mode 8) .....	5-3
5.3.1.1	Time Delay Test .....	5-3
5.3.1.2	Relay Operation .....	5-3
5.3.1.3	Calibration Switch Check .....	5-3
5.3.2	Crash (Mode 9) .....	5-3
<b>VI</b>	<b>SPARE PARTS</b>	
6.1	Replacement Parts List – Controller .....	6-1
6.2	Replacement Parts List – PFM Transmitter .....	6-2

### List of Figures

#### SECTION I – DESCRIPTION

Key Model Number .....	1-2
Table 1 - Enclosure .....	1-2
Table 2 - Supply Power .....	1-2
Table 3 - PFM Transmitter Options .....	1-3
Accessories – Standard PFM Transmitter .....	1-3
Accessories – Short-Stop™ PFM Transmitter .....	1-4

#### SECTION II – SPECIFICATIONS

#### SECTION III – INSTALLATION

Figure 3.1 – Dimensions, NEMA 4/4X (Raintight) .....	3-2
Figure 3.2 – Dimensions, Explosion-Proof .....	3-3
Figure 3.3 – Dimensions, Transmitter (All Versions) .....	3-4
Figure 3.4 – Receiver Electrical Connections .....	3-6
Figure 3.5 – Standard PFM Transmitter Electrical Connections .....	3-7
Figure 3.6 – Short-Stop™ PFM Transmitter Electrical Connections ..	3-8

#### SECTION IV – OPERATION

Figure 4.1 – Location of Controls .....	4-3
---	-----

#### SECTION V – TROUBLE SHOOTING

#### SECTION VI – SPARE PARTS

## SECTION I DESCRIPTION

### 1.1 GENERAL

The ROBERTSHAW Model 5100 Level-Lance™ is a microprocessor based, advanced technology On-Off level detection instrument. By utilizing the microprocessor, the device can be calibrated without screwdriver adjustments or knobs to turn. The simplicity of the "Auto-Set" calibration is the ultimate in level control ease of adjustment.

The Model 5100 has eight (8) separate and individual programs preprogrammed into its memory. These programs let the user select the "type" of On-Off control action best suited for the application. The eight programs are field selectable by means of a 10 position rotary switch. These program selections as indicated by the rotary switch positions are as follows:

0. **AVERAGING** — Sets the control point midway between the selected high and low point on a vertically mounted probe. This is applicable to certain special applications.
1. **CYCLIC** — (Differential) *Control* — Used where a level difference or deadband between the high and low points on a vertically mounted probe is desired. Typically used for motor or pump control.
2. **CONTROL** — (Fixed Differential) — Used to provide relay operation at a given point on a vertical or horizontal mounted sensing probe.
3. **ALARM+** — (Fixed Differential) — Used to provide single point control. Allows high level calibration while the tank or vessel level is below the desired trip point. Used with low dielectric materials and horizontally mounted probes.
4. **ALARM++** — Same as above except for use with high dielectric materials.
5. **ALARM-** — (Fixed Differential) — Used to provide single point control. Allows low level calibration while the tank or vessel level is above the desired trip point. Used with low dielectric materials and horizontally mounted probes.
6. **ALARM--** — Same as above except for use with high dielectric materials.
7. **WINDOW** — Used for special applications. Relay actuation occurs whenever the level goes above or below the selected high and low points.

Selection of the desired control type is made prior to beginning the calibration process.

The Model 5100 also has user selectable "Fail-Safe" modes of operation. High Level Fail-Safe (HLFS) or Low Level Fail-Safe (LLFS) are selected by a switch located on the main circuit board.

Field selectable time delays are also provided. The Model 5100 provides the user with a choice of time delay modes. These modes are selected with a pair of switches located on the main circuit board. The user may select no time delay, delay when the relay operates, delay when the relay returns to normal or delay when the relay operates and when it returns to normal. The length of the time delay is set by means of a pair of ten (10) position rotary switches. The delay duration is adjustable in one (1) second steps from 00 to 99 seconds.

The relay output is a Double Pole Double Throw (DPDT) type rated at 10 amps.

The system utilizes ROBERTSHAW's patented Pulse Frequency Modulation (PFM) method of level transmission. This allows the transmitter to be located up to one (1) mile from the controller. The connections between them can be made with either two (2) wires, standard probe, or three (3) wires, Short-Stop™ probe. No special cables are required.

Calibration of the system is accomplished by the "Auto-Set" feature. By pressing the appropriate calibration pushbutton the micro-processor is automatically set to look for the current level as a control point. Thus the levels corresponding to the high and low relay trip points are stored in the microprocessor's non-volatile memory. Single level trip points, with fixed differential, can be set without varying the level in the vessel by using the special control modes provided.

Power supply options include 120 VAC and 240 VAC as well as 18 to 30 VDC operation.

### 1.2 OPTIONS

The system is available in either raintight (NEMA 4) enclosures or corrosion resistant (NEMA 4X) enclosures or explosion-proof enclosures. All enclosures are available with, or without,

indicating lights. These indicating lights provide the user with convenient indication of the system status.

Another option available with the Model 5100 is the Short-Stop™ PFM transmitter and sensing probe. This option permits use of the system in applications where the product being measured will build up on the probe and/or vessel wall and eventually short the sensing probe. The Short-Stop™ feature will allow continued operation even if these conditions occur.

### 1.3 MODEL IDENTIFICATION

Identify instrument models in accordance with the description and variations listed in each table. Dashes are used in the model number only in those spaces indicated below.

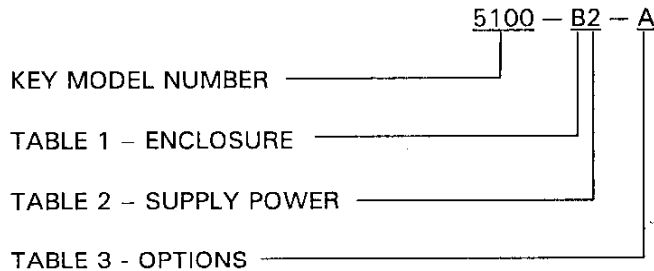

**KEY MODEL NUMBER**

DESIGNATION	DESCRIPTION
5100	MICROPROCESSOR BASED ON/OFF LEVEL DETECTOR. RECEIVER UNIT, IN AN ENCLOSURE, PER TABLE 1. ALSO INCLUDES A PROBE MOUNTED PFM TRANSMITTER IN AN EXPLOSION-PROOF ENCLOSURE.

**TABLE 1 - ENCLOSURE**

DESIGNATION	DESCRIPTION
A	NEMA 4, RAIN-TIGHT, WITHOUT INDICATOR LIGHTS
B	NEMA 4, RAIN-TIGHT WITH INDICATOR LIGHTS
C	EXPLOSION-PROOF WITHOUT INDICATOR LIGHTS
D	EXPLOSION-PROOF WITH INDICATOR LIGHTS
E	NEMA 4X, CORROSION RESISTANT (EPOXY PAINTED), WITHOUT INDICATOR LIGHTS
F	NEMA 4X, CORROSION RESISTANT (EPOXY PAINTED), WITH INDICATOR LIGHTS
G	EXPLOSION-PROOF, CORROSION RESISTANT (EPOXY PAINTED) WITHOUT INDICATOR LIGHTS
H	EXPLOSION-PROOF, CORROSION RESISTANT (EPOXY PAINTED) WITH INDICATOR LIGHTS

**TABLE 2 - SUPPLY POWER**

DESIGNATION	DESCRIPTION
1	18 TO 30 VDC
2	120 VAC ±10%, 50/60 HZ
3	240 VAC ±10%, 50/60 HZ

**TABLE 3 – PFM TRANSMITTER OPTIONS**

DESIGNATION	DESCRIPTION
A	NONE – PROBE MOUNTED PFM TRANSMITTER
B	REMOTE MOUNTED PFM TRANSMITTER*
C	PROBE MOUNTED SHORT-STOP™ PFM TRANSMITTER
D	REMOTE MOUNTED SHORT-STOP™ PFM TRANSMITTER*
E	PROBE MOUNTED, CORROSION RESISTANT (EPOXY PAINTED), PFM TRANSMITTER
F	REMOTE MOUNTED, CORROSION RESISTANT (EPOXY PAINTED), PFM TRANSMITTER*
G	PROBE MOUNTED, CORROSION RESISTANT (EPOXY PAINTED), SHORT-STOP™ PFM TRANSMITTER
H	REMOTE MOUNTED, CORROSION RESISTANT (EPOXY PAINTED), SHORT-STOP™ PFM TRANSMITTER*

\* INCLUDES NIPPLE AND FLOOR FLANGE. REQUIRES CABLE AND CONDUIT ASSEMBLY SHOWN IN ACCESSORIES BELOW (MAXIMUM ALLOWABLE CABLE LENGTH IS 15 FEET).

**ACCESSORIES – STANDARD PFM TRANSMITTER**

PART NUMBER	DESCRIPTION
032KC190-XX*	CONDUIT WITH 1/2" NPT CONNECTIONS, FLEXIBLE, LIQUID TIGHT, GENERAL PURPOSE
032KC600-XX*	COAX CABLE
032KC650-XX*	COAX CABLE WITH GENERAL PURPOSE CONDUIT
032KC700-XX*	COAX CABLE WITH NEMA 4 CONDUIT OUTLET BOX**
032KC710-XX*	COAX CABLE WITH GENERAL PURPOSE CONDUIT AND NEMA 4 CONDUIT OUTLET BOX
032KC720-02	COAX CABLE, 2 FT LONG, WITH EXPLOSION PROOF CONDUIT AND NEMA 4 CONDUIT OUTLET BOX**
032KC720-05	COAX CABLE, 5 FT LONG, WITH EXPLOSION PROOF CONDUIT AND NEMA 4 CONDUIT OUTLET BOX**
032KC720-08	COAX CABLE, 8 FT LONG, WITH EXPLOSION PROOF CONDUIT AND NEMA 4 CONDUIT OUTLET BOX**
032KC720-10	COAX CABLE, 10 FT LONG, WITH EXPLOSION PROOF CONDUIT AND NEMA 4 CONDUIT OUTLET BOX**
032KC800-XX*	COAX CABLE WITH NEMA 4X EPOXY PAINTED CONDUIT OUTLET BOX
032KC810-XX*	COAX CABLE WITH GENERAL PURPOSE CONDUIT AND NEMA 4X EPOXY PAINTED CONDUIT OUTLET BOX
032KC820-02	COAX CABLE, 2 FT LONG, WITH EXPLOSION-PROOF CONDUIT AND NEMA 4X EPOXY PAINTED CONDUIT OUTLET BOX**
032KC820-05	COAX CABLE, 5 FT LONG, WITH EXPLOSION-PROOF CONDUIT AND NEMA 4X EPOXY PAINTED CONDUIT OUTLET BOX**
032KC820-08	COAX CABLE, 8 FT LONG, WITH EXPLOSION-PROOF CONDUIT AND NEMA 4X EPOXY PAINTED CONDUIT OUTLET BOX**
032KC820-10	COAX CABLE, 10 FT LONG, WITH EXPLOSION-PROOF CONDUIT AND NEMA 4X EPOXY PAINTED CONDUIT OUTLET BOX**
032KC900-XX*	COAX CABLE WITH NEMA 4X STAINLESS STEEL CONDUIT OUTLET BOX**
032KC910-XX*	COAX CABLE WITH GENERAL PURPOSE CONDUIT AND NEMA 4X STAINLESS STEEL CONDUIT OUTLET BOX

**ACCESSORIES – STANDARD PFM TRANSMITTER - continued**

PART NUMBER	DESCRIPTION
032KC920-02	COAX CABLE, 2 FT LONG, WITH EXPLOSION-PROOF CONDUIT AND NEMA 4X STAINLESS STEEL CONDUIT OUTLET BOX**
032KC920-05	COAX CABLE, 5 FT LONG, WITH EXPLOSION-PROOF CONDUIT AND NEMA 4X STAINLESS STEEL CONDUIT OUTLET BOX**
032KC920-08	COAX CABLE, 8 FT LONG, WITH EXPLOSION-PROOF CONDUIT AND NEMA 4X STAINLESS STEEL CONDUIT OUTLET BOX**
032KC920-10	COAX CABLE, 10 FT LONG, WITH EXPLOSION-PROOF CONDUIT AND NEMA 4X STAINLESS STEEL CONDUIT OUTLET BOX**
909SD029**	CONDUIT OUTLET BOX, NEMA 4
909SD029-50**	CONDUIT OUTLET BOX, NEMA 4X, EPOXY PAINTED
909SD029-51**	CONDUIT OUTLET BOX, NEMA 4X, STAINLESS STEEL

\* SUBSTITUTE THE DESIRED CABLE LENGTH, IN FEET, FOR "XX" TO COMPLETE CABLE PART NUMBER. MAXIMUM CABLE LENGTH IS 15 FEET. COAX CABLE IS TEFLON INSULATED WITH TERMINATIONS FOR ATTACHMENT TO PROBE AND PFM TRANSMITTER. MAXIMUM TEMPERATURE IS 350°F.

\*\* CONDUIT OUTLET BOXES ARE EXPLOSION-PROOF.

**ACCESSORIES – SHORT-STOP™ PFM TRANSMITTER**

PART NUMBER	DESCRIPTION
032KF120-XX*	TRIAx CABLE
032KF130-XX*	TRIAx CABLE WITH NEMA 4 CONDUIT OUTLET BOX
032KF140-XX*	TRIAx CABLE WITH GENERAL PURPOSE CONDUIT AND NEMA 4 CONDUIT OUTLET BOX
032KF150-05	TRIAx CABLE, 5 FT LONG, WITH EXPLOSION-PROOF CONDUIT AND NEMA 4 CONDUIT OUTLET BOX**
032KF150-10	TRIAx CABLE, 10 FT LONG, WITH EXPLOSION-PROOF CONDUIT AND NEMA 4 CONDUIT OUTLET BOX**
032KF330-XX*	TRIAx CABLE WITH NEMA 4X EPOXY PAINTED CONDUIT OUTLET BOX
032KF340-XX*	TRIAx CABLE WITH GENERAL PURPOSE CONDUIT AND NEMA 4X EPOXY PAINTED CONDUIT OUTLET BOX
032KF350-05	TRIAx CABLE, 5 FT LONG, WITH EXPLOSION-PROOF CONDUIT AND NEMA 4X EPOXY PAINTED CONDUIT OUTLET BOX**
032KF350-10	TRIAx CABLE, 10 FT LONG, WITH EXPLOSION-PROOF CONDUIT AND NEMA 4X EPOXY PAINTED CONDUIT OUTLET BOX**
040KB534**	CONDUIT OUTLET BOX, NEMA 4
040KB534-01**	CONDUIT OUTLET BOX, NEMA 4X EPOXY PAINTED

\* SUBSTITUTE THE DESIRED CABLE LENGTH, IN FEET, FOR "XX" TO COMPLETE CABLE PART NUMBER. MAXIMUM CABLE LENGTH IS 15 FEET. TRIAX CABLE IS TEFLON INSULATED WITH TERMINATIONS FOR ATTACHMENT TO PROBE AND PFM TRANSMITTER. MAXIMUM TEMPERATURE IS 350°F.

\*\* CONDUIT OUTLET BOXES ARE EXPLOSION-PROOF.

## SECTION II SPECIFICATIONS

### 2.1 ELECTRICAL/ELECTRONIC

**Supply Voltage:**

120 VAC  $\pm 10\%$ , 50/60 Hz. – Standard  
240 VAC  $\pm 10\%$ , 50/60 Hz. – Optional  
18 to 30 VDC – Optional

**Supply Power:**

10 VA (Max.)

**Control Range:**

0.1 to 3000 pF

**Adjustable Differential:**

0.2 pF to 100% of Control Range

**Adjustable Time Delay:**

0 to 99 Seconds

**Ambient Temperature Effect:**

$\pm 0.005$  pF/°F or  $\pm 0.01$  %/°F,  
Whichever is Greater

**Supply Variation Effect:**

None

**Linearity:**

$\pm 0.5$  %

**Resolution:**

0.1 pF

**Repeatability:**

$\pm 0.1$  pF

**Relay Output:**

Type = Electro-Mechanical  
Contacts = DPDT, 10 Amp @ 120/240 VAC,  
10 AMP @ 30 VDC, Non-Inductive

**Maximum Distance Between The Transmitter and Receiver:**

One (1) Mile

**Type of Interconnecting Cable:**

Two (2) Wires (Twisted Pair) for Standard PFM Transmitter (BELDEN #8205 or #8762, Shielded) or Three (3) Wires (BELDEN #9492 or #9364, Shielded) for Short-Stop™ PFM Transmitter.

### 2.2 ENVIRONMENTAL

**Temperature (Operating or Storage):**

-40°F to +140°F  
(-40°C to +60°C)

**Relative Humidity:**

0 to 95%, Non-Condensing

**Vibration:**

$\pm 2$  G, 10 to 200 Hz

**Shock:**

75 g's for 11 ms Without Permanent Damage

### 2.3 ENCLOSURE

**PFM Transmitter:**

Raintight, NEMA 4 – Standard

Raintight, Corrosion Resistant, NEMA 4X-  
Optional

Explosion-Proof: Suitable for Class I,  
Division 1, Groups C & D or Class II,  
Division 1, Groups E, F & G – Optional

Explosion-Proof, Corrosion Resistant,  
Suitable for Class I, Division 1, Groups  
C & D or Class II, Division 1, Groups E,  
F & G – Optional

**Model 5100 Receiver:**

Raintight, NEMA 4 – Standard

Raintight, Corrosion Resistant, NEMA  
4X – Optional

Explosion-Proof: Suitable for Class I,  
Division 1, Groups C & D or Class II,  
Division 1, Groups E, F & G – Optional

Explosion-Proof, Corrosion Resistant,  
Suitable for Class I, Division 1, Groups  
C & D or Class II, Division 1, Groups E,  
F & G – Optional

**Weight:**

Transmitter: 2.8 lbs. (1.27 Kg)

Receiver:

Raintight: 6.5 lbs. (2.95 Kg)

Explosion-Proof: 8 lbs. (3.63 Kg)



## 2.4 INTRINSIC SAFETY

### **Standard PFM Transmitter and Probe:**

UL & c-UL Certified as intrinsically safe for Class I, Division 1, Groups A, B, C & D; Class II, Division 1, Groups E, F & G; and Class I, Zone 0, Group IIC hazardous locations when connected as shown on drawing 907GA811. A barrier is required.

### **Short-Stop™ PFM Transmitter and Probe:**

Not intrinsically safe.

## **SECTION III** **INSTALLATION**

### **3.1 GENERAL**

Examine the instrument for possible shipping damage. **IMPORTANT:** If for any reason it is determined that parts should be returned to the factory, please notify the nearest ROBERTSHAW sales representative prior to shipment. Each unit must be properly packaged to prevent damage in transit. Robertshaw assumes no responsibility for equipment damaged in shipment due to improper packaging.

Choose the mounting location in accordance with good instrument practice, avoiding extremes of temperature, humidity and vibration. (See SPECIFICATIONS, SECTION 2)

### **3.2 PROBE MOUNTING**

Robertshaw probes are purchased separately in a variety of sizes and types for specific applications involving liquids or granular materials. Insulated rod-type probes are used for liquid solutions or liquid interface detection where the product is electrically conductive. Bare type probes can be used on non-conductive materials only.

The face of the packing gland on rod-type probes must be installed so that it is nearly flush with the vessel wall. When installing the probe in a nozzle, recess, or open end well, a sheathed probe should be used, with the sheathed length equal to the nozzle, recess, or well length.

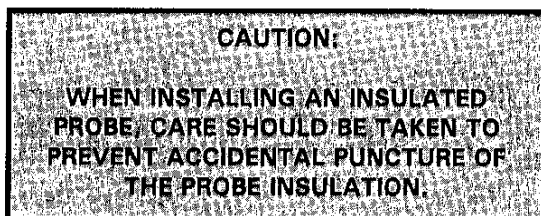

### **3.2.1 HORIZONTAL MOUNTING**

Horizontally mounted rod-type probes must be installed in the vessel at the desired point of level detection. Horizontally mounted probes provide the closest control (smallest deadband) in that a small level change at or near the probe will produce a large capacitance change.

On applications involving viscous liquids or materials that have a tendency to "cling" or "build-up", it is recommended that the probe be mounted on a slight downward angle to permit draining of the material from the probe.

### **3.2.2 VERTICAL MOUNTING**

Vertically mounted rod-type probes should be installed either in the top or bottom of the vessel with the mid-point on the probe corresponding to approximately the desired level detection point. Vertically installed probes allow a variation in the level detection point up and down the length of the probe by means of the instrument "AUTO-SET" adjustment.

### **3.3 INSTRUMENT MOUNTING**

The Model 5100 Level-Lance™ is designed for mounting remotely from the probe and PFM transmitter and may be mounted or oriented in any position. See the following figures for mounting dimensions. The unit should always be mounted in the factory supplied enclosure. However, if this is not possible, make certain that the electronic chassis is properly shielded from electrical interference caused by devices such as motor starters, relays, etc.

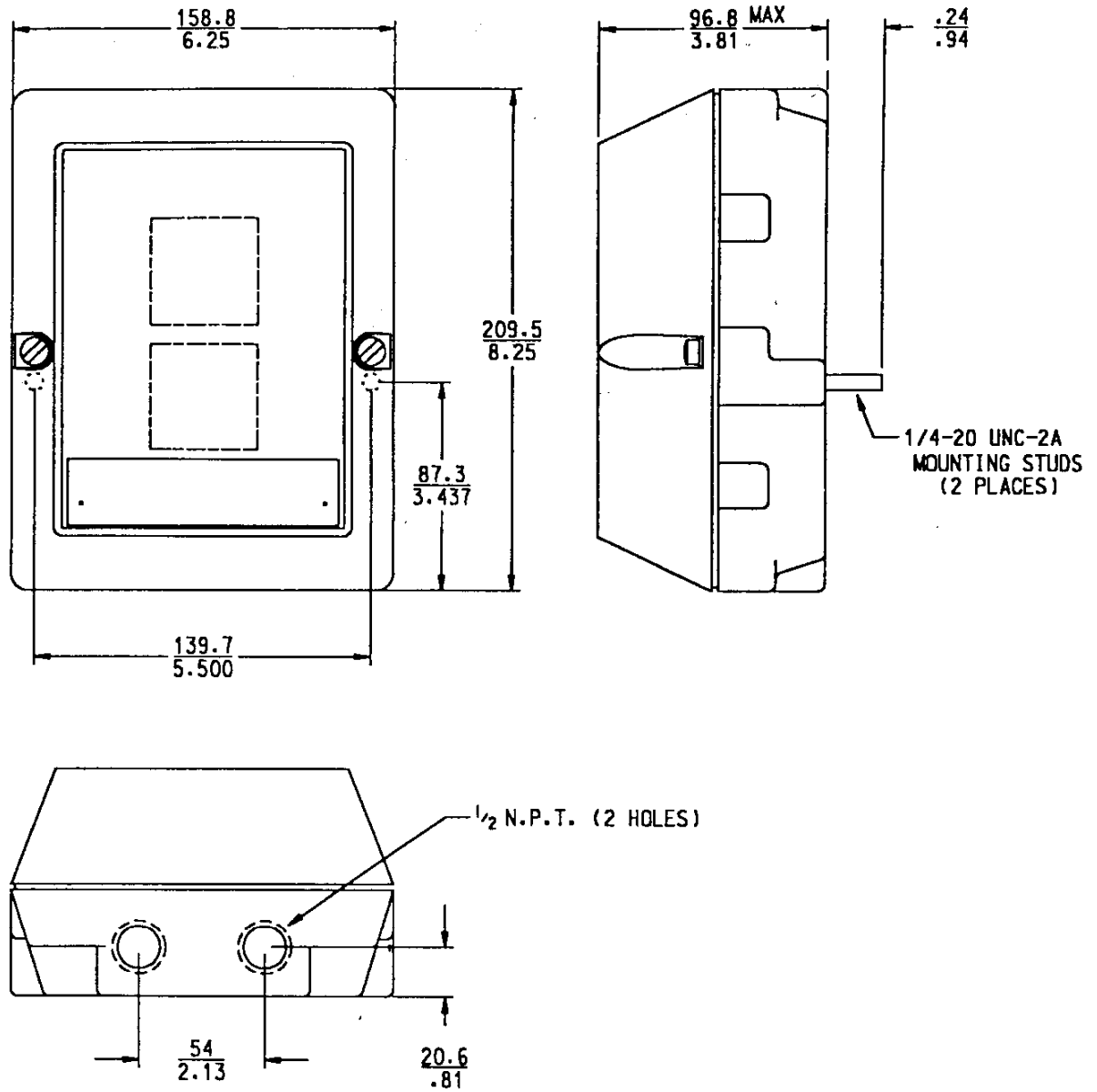

Figure 3.1 – Dimensions NEMA 4/4X (Raintight)

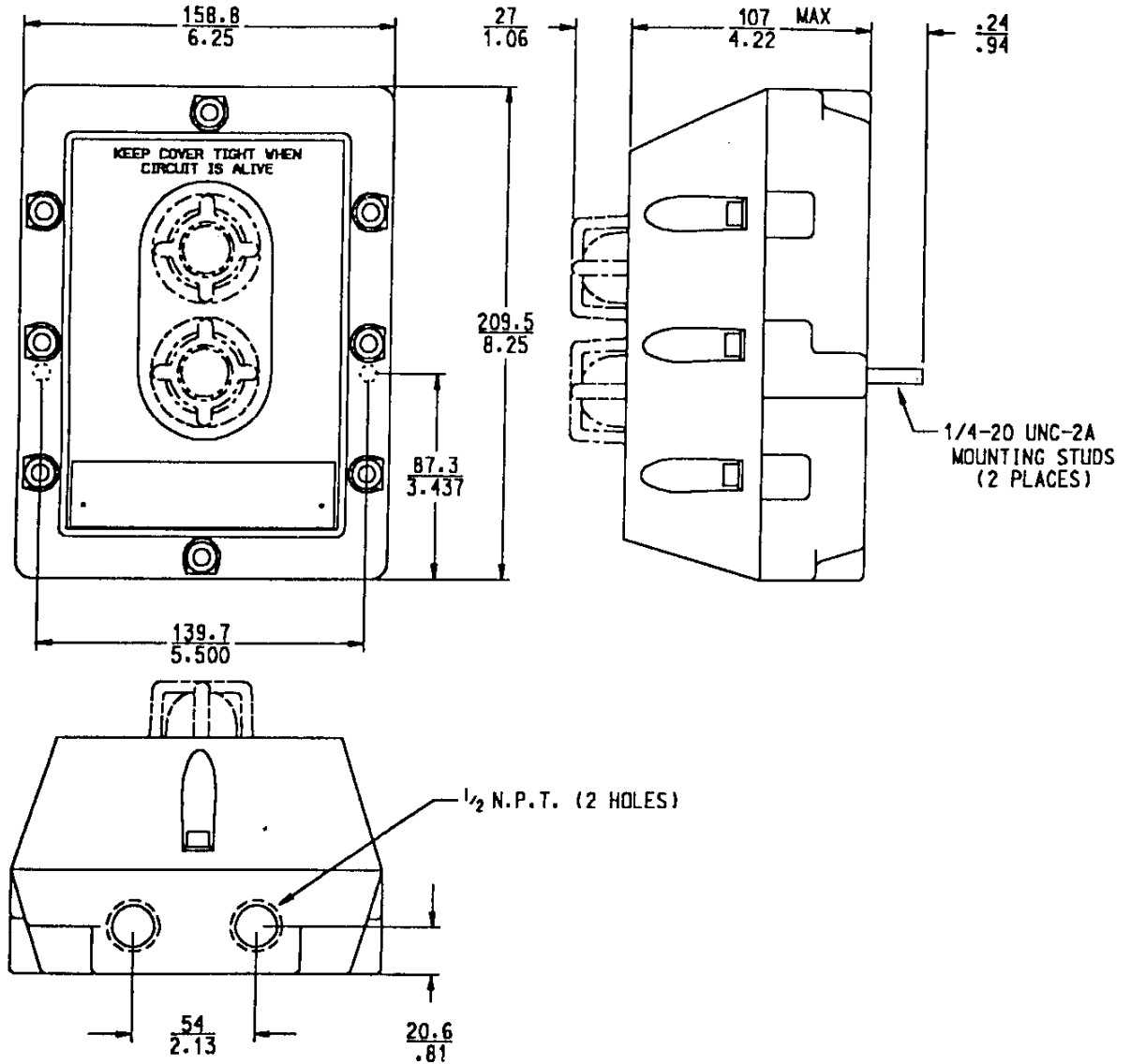

Figure 3.2 – Dimensions, Explosion-Proof (Cl. I, Div. 1, Gr. C & D, Cl. II, Div. 1, Gr. E, F & G)

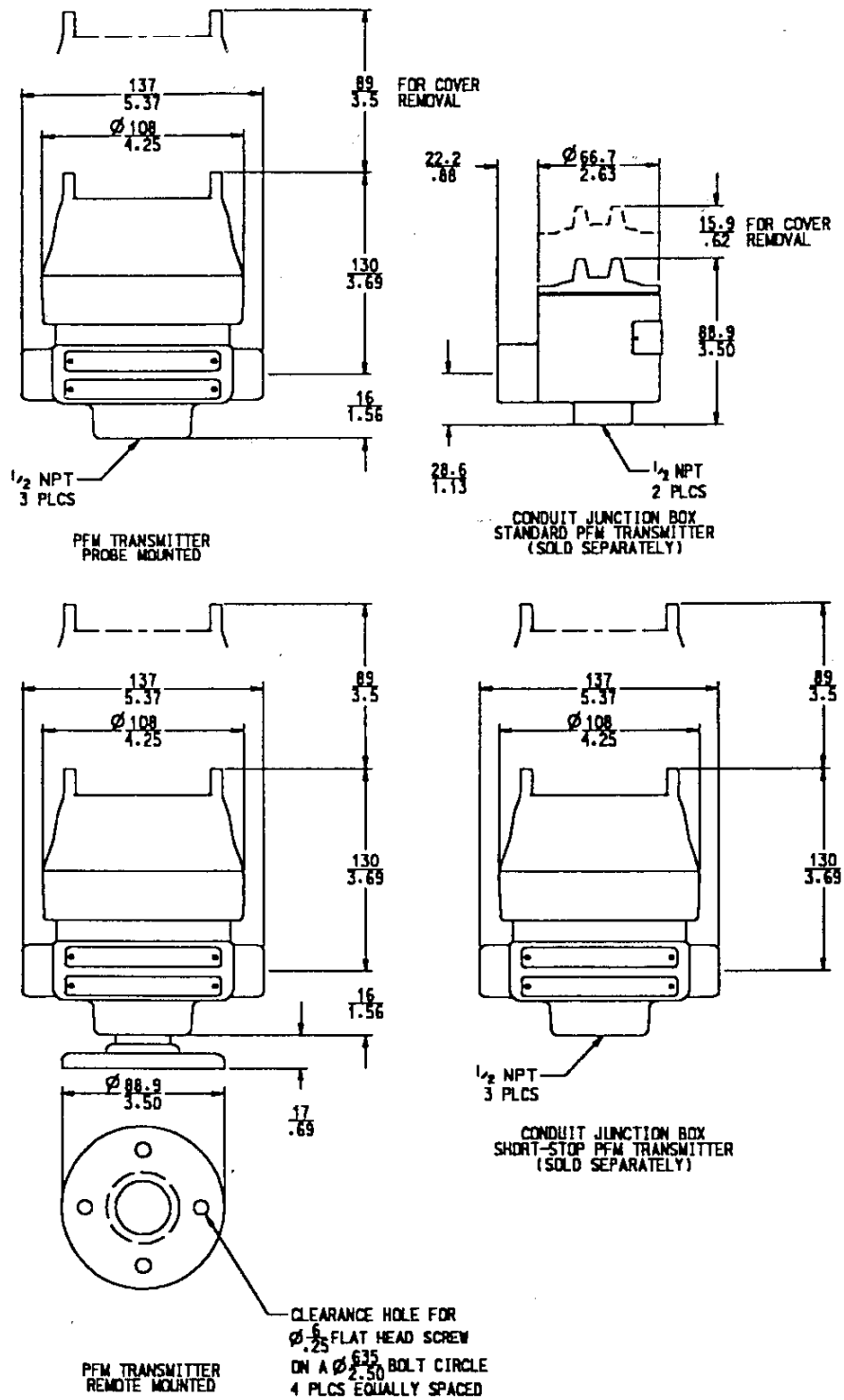

Figure 3.3 – Dimensions Transmitter (All Versions)

### 3.4 ELECTRICAL CONNECTIONS

All electrical connections should be made in accordance with the following figures. See SPECIFICATIONS, SECTION 2, for relay contact ratings. The unit must be grounded for proper operation. Also, all wiring must conform to any applicable codes.

For intrinsically safe PFM Transmitter and probe installation (standard transmitter only), refer to the PFM Transmitter instruction manual. Short-Stop™ PFM Transmitter and probe not rated for intrinsic safety.



#### 3.4.1 INTERCONNECTING CABLE

The Standard PFM Transmitter is normally mounted directly on the sensing probe assembly and is connected to the Level-Lance™ control unit using two wires (color coded, twisted pair cable is recommended) in grounded metal conduit with no power lines present. Otherwise shielded, 2 conductor, cable must be used for this connection. BELDEN #8205 cable is recommended in grounded metal conduit and BELDEN #8762 is recommended for all other installations.

The optional remote mounted Standard PFM Transmitter can be installed up to a maximum distance of fifteen (15) feet from the sensing probe. The connections between the receiver and transmitter are made as described above. The connection between the transmitter and the probe must be made using high temperature TEFLON insulated coaxial cable (RG-62/U).

The outer shield of the coaxial cable should be connected to the GND terminal on the PFM transmitter and to the green ground screw in the probe mounted conduit outlet box. The center conductor should be connected to the PROBE terminal on the PFM transmitter and to the probe rod in the probe mounted conduit outlet box.

The Short-Stop™ PFM transmitter requires three (3) conductors (color coded, 3 conductor, cable is

recommended) in grounded metal conduit with no power lines present. Otherwise shielded cable must be used for this connection. BELDEN #9492 cable is recommended in grounded metal conduit and BELDEN #9364 is recommended for all other applications.

The optional remote mounted Short-Stop™ PFM Transmitter can be installed up to a maximum distance of fifteen (15) feet from the sensing probe. The connections between the receiver and transmitter are made as described above. The connection between the transmitter and the probe must be made using high temperature TEFLON insulated triaxial cable (RG-59/U).

The outer shield of the triaxial cable should be connected to the G terminal on the PFM transmitter and to the green ground screw in the probe mounted conduit outlet box. The inner shield of the triaxial cable should be connected to the SHLD terminal on the PFM transmitter and to the Short-Stop™ element of the probe in the conduit outlet box. This connection is made using one of the terminals on the terminal strip in the conduit outlet box. The center conductor of the triaxial cable should be connected to the P terminal on the PFM transmitter and to the probe rod in the conduit outlet box.

#### 3.4.2 RELAY CONTACT TERMINALS

ARC suppression networks are provided with the unit for installation across the load when switching inductive loads such as relay coils, motors, solenoid valves, etc. It is important that these networks be used to prevent problems caused by interference generated by arcing contacts.

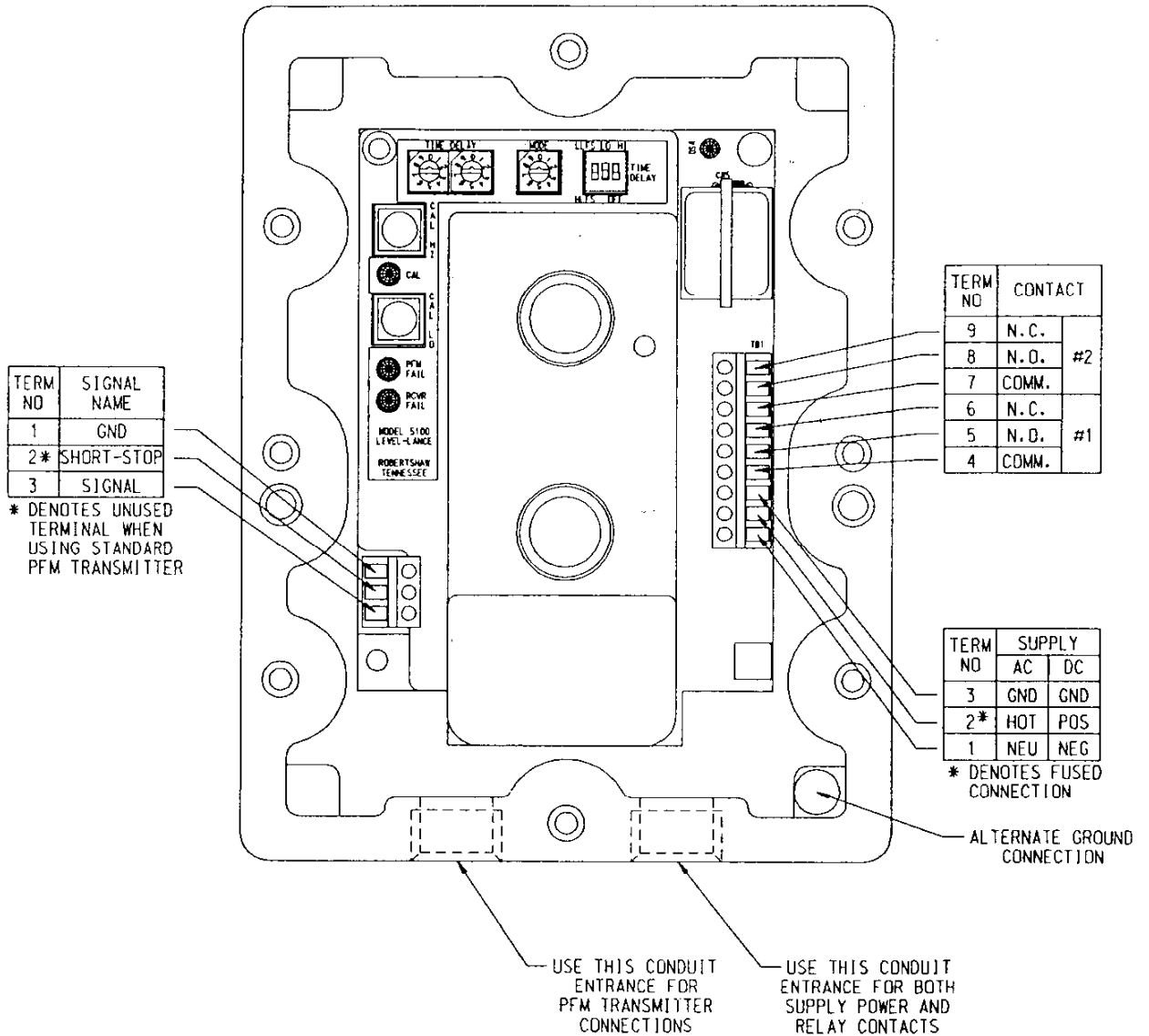

THE ALARM CONTACTS ARE SHOWN IN THE DE-ENERGIZED, ALARM, CONDITION.

Figure 3.4 – Receiver Electrical Connections

**NOTICE:**  
TIGHTEN FIELD WIRING TERMINAL SCREWS TO 5 POUND-INCHES (0.56 NM)

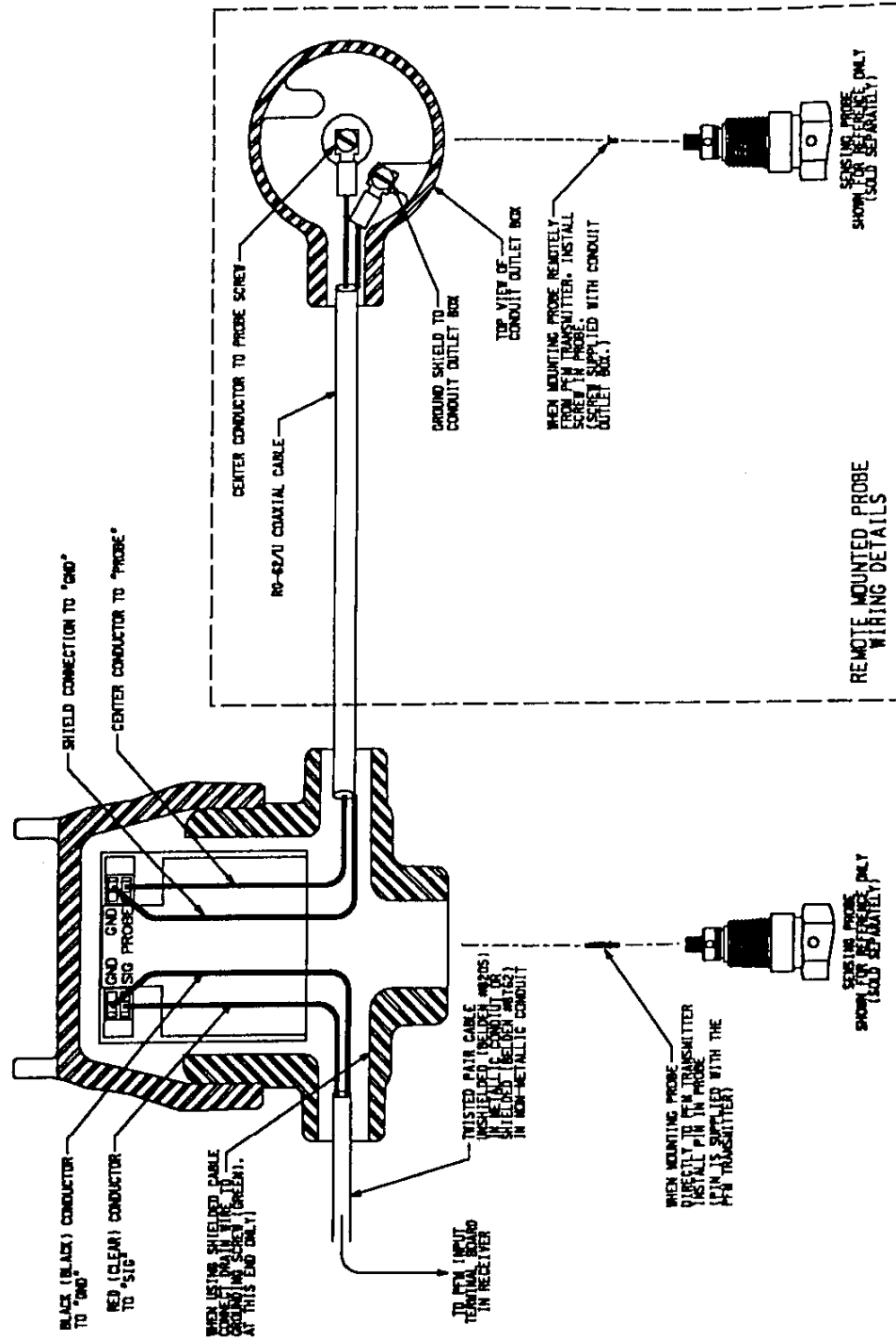

Figure 3.5 – Standard PFM Transmitter Electrical Connections

**NOTICE:**  
TIGHTEN FIELD WIRING TERMINAL SCREWS TO 5 POUND-INCHES (0.56 NM)



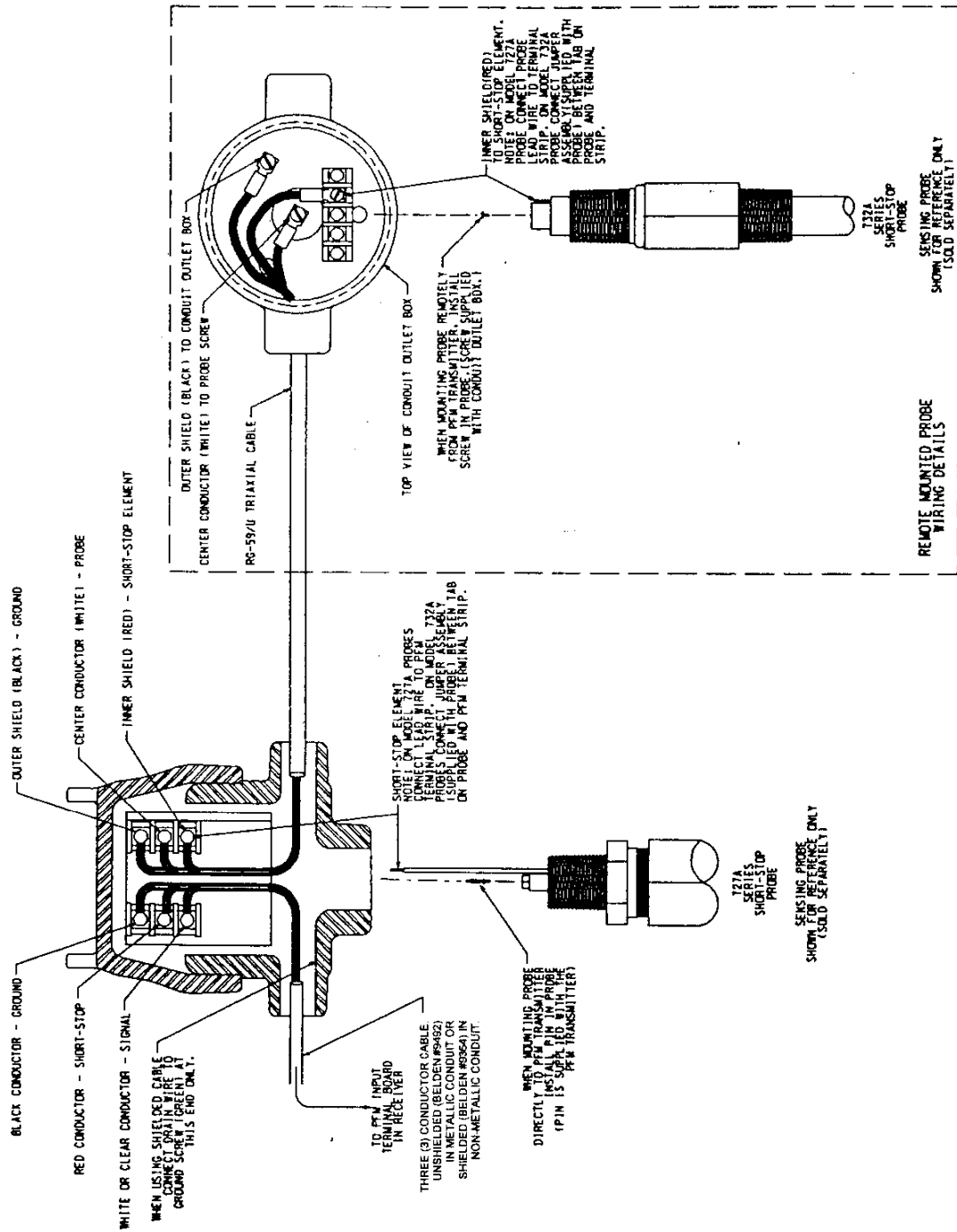

Figure 3.6 – Short-Stop™ PFM Electrical Connections

**NOTICE:**

**TIGHTEN FIELD WIRING TERMINAL SCREWS TO 5 POUND-INCHES (0.56 NM)**

## SECTION IV OPERATION

### 4.1 DISPLAYS AND INDICATORS

All controls and indicators for calibration and operation of the Model 5100 Level-Lance™ are located on the receiver printed circuit board assembly (PCA). There are no user controls or adjustments for the PFM transmitter. See the following figure for the location of the receiver controls and indicators.

**NOTE:**  
**UTILIZATION OF THESE CONTROLS**  
**REQUIRES THE REMOVAL OF THE COVER.**  
**REMOVING THE COVER OF EXPLOSION-**  
**PROOF UNITS VIOLATES THE EXPLOSION-**  
**PROOF RATING OF THE MODEL 5100**  
**RECEIVER.**

#### 4.1.1 STATUS AND ALARM INDICATORS

There are four light emitting diode (LED) indicators that are used to indicate the operational status of the Model 5100. These indicators and their function are as follows:

- CAL Failure - Indicates that the calibration data stored in EEPROM is not valid. Also used to indicate the acceptance of calibration input.
- PFM Failure - Indicates a problem with the signal from the PFM transmitter.
- RCVR Failure - Indicates a problem with the receiver portion of the instrument.
- Relay Status - Indicates that the relay contacts are in the normal or energized state.

#### 4.1.2 SWITCHES AND CONTROLS

There are six control and configuration switches that determine the operational characteristics of the model 5100 Level-Lance™.

- TIME DELAY - These two (2) ten position rotary switches, SW2 and SW3, are used to set the time delay between the

detection of a relay trip condition and the actual operation of the relay. The time delay period can be set from 0 to 99 seconds.

- FAIL-SAFE - This is the first switch, SW1-1, of the three (3) unit switch bank, SW1. It is used to determine the fail-safe mode of the relay. OFF=High Level Fail-Safe (HLFS) and ON=Low Level Fail-Safe (LLFS).
- DELAY LOW - This is the second switch, SW1-2, of the three (3) unit switch bank, SW1. It is used to control the time delay that occurs when the detected level falls below the trip point. ON=time delay and OFF=no time delay. NOTE: The time delay period is determined by the setting of SW2 and SW3.
- DELAY HIGH - This is the third switch, SW1-3, of the three (3) unit switch bank, SW1. It is used to control the time delay that occurs when the detected level rises above the trip point. ON=time delay and OFF=no time delay. NOTE: The time delay period is determined by the setting of SW2 and SW3.
- CAL HIGH - This pushbutton switch, SW5, is used to set the High trip point into the receiver non-volatile memory. NOTE: The CAL Failure LED is used to indicate acceptance of this action.
- CAL LOW - This pushbutton switch, SW6, is used to set the Low trip point into the receiver non-volatile memory. NOTE: The CAL Failure LED is used to indicate acceptance of this action.
- MODE - This ten (10) position rotary switch, SW3, is used to select the operating mode of the instrument. The modes available are shown in the following table:

POSITION	OPERATING MODE
0	AVERAGE
1	CYCLIC (Adjustable Differential)
2	CONTROL (Fixed Differential)
3	ALARM +
4	ALARM + +
5	ALARM-
6	ALARM --
7	WINDOW
8	TEST
9	CRASH

#### 4.2 SELECTING THE FAIL-SAFE MODE

The model 5100 Level-Lance™ is designed with switch selectable fail-safe modes. This switch can be set by the user to determine the relay contact action upon loss of power. The switch positions are marked "ON" and "OFF" with "OFF" being High Level Fail-Safe (HLFS) and "ON" being Low Level Fail-Safe (LLFS). Set this switch to the appropriate position as determined from the definitions below.

Applications for high level detection should utilize the High Level Fail-Safe mode which is defined as an increase in capacitance or level above the trip point causes the relay to become de-energized. Loss of electrical power or other failure would also cause the relay to be de-energized indicating a high level or unsafe condition.

Applications for low level detection should utilize the Low Level Fail-Safe mode which is defined as a decrease in capacitance or level below the trip point causes the relay to become de-energized. Loss of electrical power or other failure would also cause the relay to become de-energized indicating a low level or unsafe condition.

#### 4.3 SELECTING TIME DELAY

The Model 5100 Level-Lance™ is designed with switch selectable time delay modes. The time delay mode switches, "DELAY LOW" and "DELAY HIGH" should be set in accordance with the time delay action required by the application. Please note that the time delay period is the same for both modes and is set by the pair of "TIME DELAY" rotary switches. Each of the time delay mode switches has an "ON" and "OFF" position where

ON=delay and OFF=no delay. "DELAY LOW" causes the operation of the relay relative to the detected level falling below the trip point to occur up to 1 to 99 seconds after the level actually falls below the trip point. "DELAY HIGH" causes the operation of the relay relative to the detected level rising above the trip point to occur 1 to 99 seconds after the level actually rises above the trip point.

#### 4.4 SELECTING THE OPERATING MODE

Eight (8) operating modes are available on the Model 5100 Level-Lance™. Selection of one of the modes listed below is made using the ten (10) position "MODE" rotary switch (SW3). The switch is marked with the numbers listed below:

**NOTE: ONLY POSITIONS 3 (ALARM +) AND 4 (ALARM + +) MAY BE USED WITH A SHORT-STOP™ PROBE. ALL 8 POSITIONS MAY BE USED WITH A STANDARD PROBE**

**Position #0 AVERAGING:** This mode is designed for special applications only. The actual trip point will be midway between selected high and low points on the probe.

**Position #1 CYCLIC (Adjustable Differential):** This mode is designed to maintain the level in the vessel between selected high and low points on the probe employing cyclic control of a pump, valve, etc. This type of operation is also referred to as differential control.

**Position #2 CONTROL:** This mode is designed to provide relay operation at a given point on the probe.

**Position #3 ALARM +:** This mode is designed for probes used on granular or low dielectric materials. It is used to set a trip point with an empty vessel when the material rising to the probe is to cause relay actuation to occur.

**Position #4 ALARM + +:** This mode is the same as "ALARM +" described above except that it is designed for probes used on conductive or higher dielectric materials.

**Position #5 ALARM -:** This mode is designed for probes used on granular or low dielectric materials. It is used to set a trip point when product is present (vessel is full) and cannot be removed to set the alarm point. A decrease in material around the probe causes the relay actuation.

**Position #6 ALARM--:** This mode is the same as "ALARM-" described above except that is designed for probes used on conductive or higher dielectric materials.

**Position #7 WINDOW:** This mode is designed for special applications only. The relay actuation occurs whenever the level is between the selected high and low points on the probe (HLFS) or whenever the level is not between the two points (LLFS).

NOTE: Positions #8 and #9 are used for testing and diagnostics and should not be selected as operating modes. Refer to Section 5.3 for a description of these modes.

## 4.5 CALIBRATION PROCEDURE

After the Model 5100 Level-Lance™ is installed and all wiring connections are completed, turn on the power to the unit and allow it to warm up for approximately five (5) minutes before proceeding.

Perform one of the following procedures based on the selected Operating Mode. In the following procedures, calibration is accomplished using the "CAL HIGH" and/or "CAL LOW" pushbuttons.

**NOTE:**  
SELECTION OF THE OPERATING MODE MUST TAKE PLACE BEFORE CALIBRATION IS PERFORMED

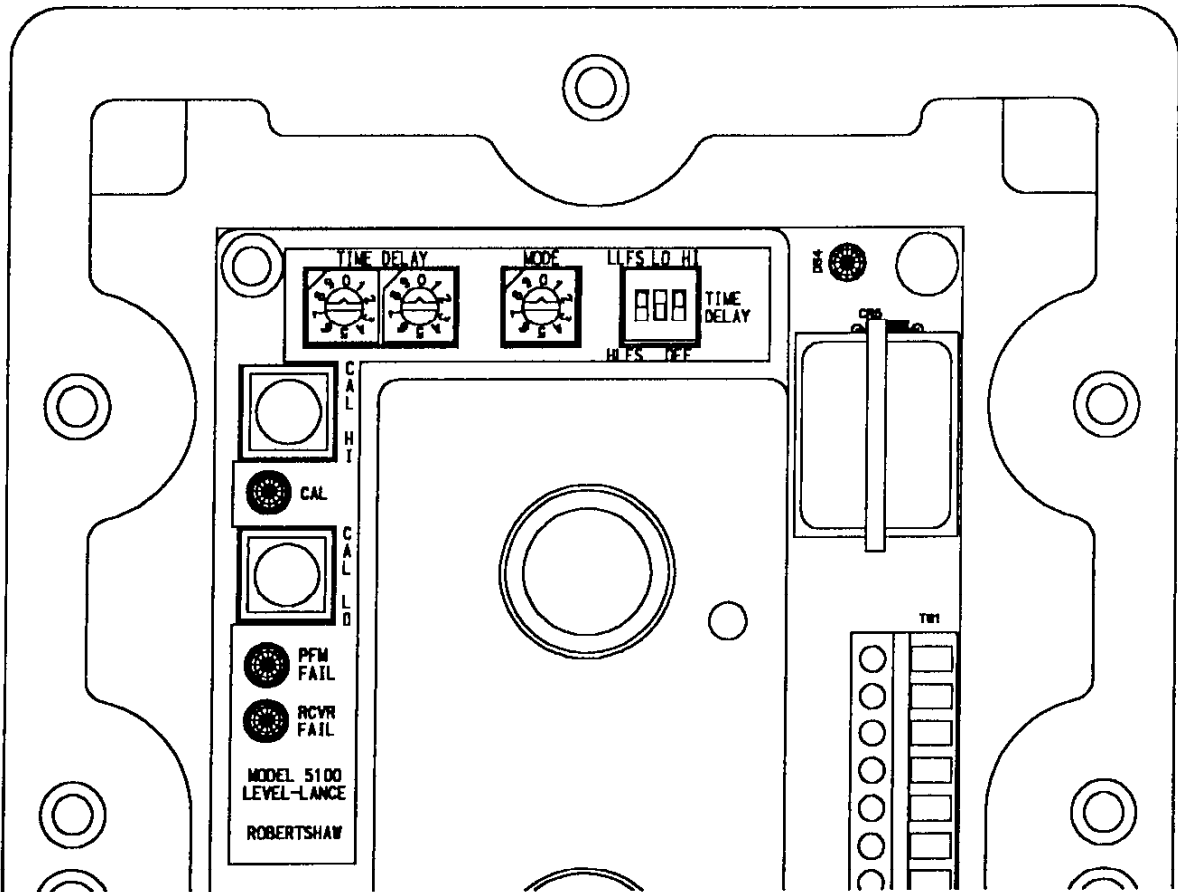

Figure 4.1 – Location of Controls

**Procedure A:** AVERAGING (Mode 0),  
CYCLIC (Mode 1),  
WINDOW (Mode 7)  
Bring the product level in the vessel to the desired low operating point on the sensing probe. Press and hold the "CAL LO" pushbutton until the "CAL" LED comes on. Raise the product level to the desired high point on the probe. Press and hold the "CAL HI" pushbutton until the "CAL" LED comes on. The instrument is now calibrated.

**NOTE:** THIS PROCEDURE IS NOT TO BE USED WITH THE SHORT-STOP™ OPTION.

**Procedure B:** CONTROL, FIXED DIFFERENTIAL (Mode 2)  
(SINGLE POINT CALIBRATION, LOW LEVEL FAIL-SAFE)  
Bring the product to the desired operation point on the sensing probe. Press and hold the "CAL LO" pushbutton until the "CAL" LED comes on. The instrument is now calibrated.

**NOTE:** THIS PROCEDURE IS NOT TO BE USED WITH THE SHORT-STOP™ OPTION.

**Procedure C:** CONTROL, FIXED DIFFERENTIAL (Mode 2)  
(SINGLE POINT CALIBRATION, HIGH LEVEL FAIL-SAFE)  
Bring the product to the desired operating point on the sensing probe. Press and hold the "CAL HI" pushbutton until the "CAL" LED comes on. The instrument is now calibrated.

**NOTE:** THIS PROCEDURE IS NOT TO BE USED WITH THE SHORT-STOP™ OPTION.

**Procedure D:** ALARM + (Mode 3),  
ALARM + + (Mode 4)  
(LOW LEVEL FAIL-SAFE)  
This procedure is used when the vessel is empty or the level is significantly below the operating point on the sensing probe. Press and hold the "CAL LO" pushbutton until the "CAL" LED comes on. The instrument is now calibrated.

**NOTE:** THIS PROCEDURE MAY BE USED WITH EITHER A STANDARD OR A SHORT-STOP™ PROBE.

**Procedure E:** ALARM + (Mode 3),  
ALARM + + (Mode 4)  
(HIGH LEVEL FAIL-SAFE)  
This procedure is used when the vessel is empty or the level is significantly below the operating point on the sensing probe. Press and hold the "CAL HI" pushbutton until the "CAL" LED comes on. The instrument is now calibrated.

**NOTE:** THIS PROCEDURE MAY BE USED WITH EITHER A STANDARD OR A SHORT-STOP™ PROBE.

**Procedure F:** ALARM- (Mode 5),  
ALARM--(Mode 6)  
(LOW LEVEL FAIL-SAFE)  
This procedure is used when the vessel is full. Press and hold the "CAL LO" pushbutton until the "CAL" LED comes on. The instrument is now calibrated.

**NOTE:** THIS PROCEDURE IS NOT TO BE USED WITH THE SHORT-STOP™ OPTION.

**Procedure G:** ALARM- (Mode 5),  
ALARM--(Mode 6)  
(HIGH LEVEL FAIL-SAFE)  
This procedure is used when the vessel is full. Press and hold the "CAL HI" pushbutton until the "CAL" LED comes on. The instrument is now calibrated.

**NOTE:** THIS PROCEDURE IS NOT TO BE USED WITH THE SHORT-STOP™ OPTION.

## 4.6 CALIBRATION EXAMPLES

The following paragraphs illustrate the procedures for calibrating the Model 5100 Level-Lance™ for some of the more common modes of operation. Each example includes a step by step procedure to accomplish the desired calibration.

### 4.6.1 HIGH LEVEL ALARM

The calibration for high level detection can be done in several different operating modes, depending on the existing conditions in the vessel being monitored. The following description assumes that a horizontally mounted probe is used

and that the probe is mounted at the desired high level trip point. In all cases the fail-safe mode will be "HIGH Level Fail-Safe", HLFS.

#### 4.6.1.1 EMPTY VESSEL CALIBRATION

If the vessel is empty and the material being measured has a low dielectric constant then the desired operating mode would be "ALARM+", but if the material has a high dielectric constant then the operating mode would be "ALARM++". The difference in these two (2) operating modes is that "ALARM++" requires a larger increase in measured capacitance (Level) than does "Alarm+". The following steps are required to perform this calibration:

1. Place the first switch, SW1-1, of the three (3) position dip switch in the "HLFS" position.
2. Place the 10 position rotary "MODE" switch, SW3, in the appropriate position, "ALARM+" or "ALARM++".
3. Press and hold the "CAL HIGH" pushbutton until the "CAL" LED is illuminated.

Calibration of the unit is now complete and the relay will be de-energized when the level reaches the probe (alarm condition).

#### 4.6.1.2 FULL VESSEL CALIBRATION

If the vessel is full and the material being measured has a low dielectric constant then the desired operating mode would be "ALARM-", but if the material has a high dielectric constant then the operating mode would be "ALARM--". Again the difference in the two (2) operating modes is that "ALARM--" requires a larger change in measured capacitance (LEVEL) than does "ALARM-". The following steps are required to perform this calibration:

1. Place the first switch, SW1-1, of the three (3) position dip switch in the "HLFS" position.
2. Place the 10 position rotary "MODE" switch, SW3, in the appropriate position, "ALARM-" or "ALARM--".
3. Press and hold the "CAL HIGH" pushbutton until the "CAL" LED is illuminated.

Calibration of the unit is now complete and the relay will be energized when the level drops below the probe (non-alarm condition).

#### 4.6.2 LOW LEVEL CALIBRATION

The calibration for low level detection can be done in several operating modes, depending on the existing conditions in the vessel being monitored. The following description assumes that a horizontally mounted probe is being used and that the probe is mounted at the desired low level trip point. In all cases the fail-safe mode will be "Low Level Fail-Safe", LLFS.

##### 4.6.2.1 EMPTY VESSEL CALIBRATION

If the vessel is empty and the material being measured has a low dielectric constant then the desired operating mode would be "ALARM+", but if the material has a high dielectric constant then the operating mode would be "ALARM++". The difference in the two (2) operating modes is that "ALARM++" requires a larger change in measure capacitance (LEVEL) than does "ALARM+". The following steps are required to perform this calibration:

1. Place the first switch, SW1-1, of the three (3) position dip switch in the "LLFS" position.
2. Place the 10 position rotary "MODE" switch, SW3, in the appropriate position, "ALARM+" or "ALARM++".
3. Press and hold the "CAL LOW" pushbutton until the "CAL" LED is illuminated.

Calibration of the unit is now complete and the relay will be energized when the level reaches the probe (non-alarm condition).

##### 4.6.2.2 FULL VESSEL CALIBRATION

If the vessel is full and the material being measured has a low dielectric constant then the desired operating mode would be "ALARM-", but if the material has a high dielectric constant then the operating mode would be "ALARM--". Again the difference between these two modes is that "ALARM--" requires a larger change in measured capacitance (LEVEL) than does "ALARM-". The following steps are required to perform this calibration:

1. Place the first switch, SW1-1, of the three (3) position dip switch in the "LLFS" position.
2. Place the 10 position rotary "MODE" switch, SW3, in the appropriate position, "ALARM-" or "ALARM--".
3. Press and hold the "CAL LOW" pushbutton until the "CAL" LED is illuminated.

Calibration of the unit is now complete and the relay will be de-energized when the level drops below the probe (alarm condition).

### 4.6.3 SINGLE POINT CALIBRATION

When the Model 5100 Level-Lance™ is used with a vertically mounted probe a common application is to have the instrument sense when the level being monitored either rises above a predetermined level or falls below the level selected. In either case this type of calibration requires that the level in the vessel be changed about the desired trip point.

#### 4.6.3.1 HIGH LEVEL SENSING

The level in the vessel must be brought to the level of the desired trip point and then the following steps are required to perform this calibration:

1. Place the first switch, SW1-1, of the three (3) position dip switch in the "HLFS" position.
2. Place the 10 position rotary "MODE" switch, SW3, in the "Control" (Mode 2) position.
3. Press and hold the "CAL HIGH" pushbutton until the "CAL" LED is illuminated.

Calibration of the unit is now complete and the relay will be de-energized (alarm condition) whenever the level rises to the calibration point and the relay will return to the normal, energized, state when the level falls below this point.

#### 4.6.3.2 LOW LEVEL SENSING

The level in the vessel must be brought to the level of the desired trip point and then the following steps are required to perform this calibration:

1. Place the first switch, SW1-1, of the three (3) position dip switch in the "LLFS" position.
2. Place the 10 position rotary "MODE" switch, SW3, in the "Control" position.
3. Press and hold the "CAL LOW" pushbutton until the "CAL" LED is illuminated.

Calibration of the unit is now complete and the relay will be de-energized whenever the level falls below the calibration point (alarm condition) and it will return to the energized (normal) state when the level rises above this point.

### 4.6.4 ADJUSTABLE DIFFERENTIAL

A common application for the use of differential is pump control on a sump or wet well. In these applications the probe is vertically mounted and two (2) individual trip points are used to determine the operation of a pump. The pump is turned on whenever the level rises to the high trip point and continues to run until the level falls to the low trip point. In this application "High Level Fail-Safe", "HLFS", is used to prevent the well or sump from overflowing.

#### 4.6.4.1 HIGH POINT CALIBRATION

The level in the well or sump must be brought to the level of the desired trip point and then the following steps are required to perform this calibration:

1. Place the first switch, SW1-1, of the three (3) position dip switch in the "HLFS" position.
2. Place the 10 position rotary "MODE" switch, SW3, in the "Cyclic" position.
3. Press and hold the "CAL HIGH" pushbutton until the "CAL" LED is illuminated.

#### 4.6.4.2 LOW POINT CALIBRATION

The level in the well or sump must be lowered to the desired trip point and then the following step is required to perform this calibration:

1. Press and hold the "CAL LOW" pushbutton until the "CAL" LED is illuminated.

Calibration is now complete and the pump will remain off until the level rises to the high trip point.

**SECTION V**  
**TROUBLE SHOOTING**

**5.1 TROUBLE SHOOTING CHART**

If operational problems are encountered, locate the appropriate symptom in the following chart and take the indicated corrective action.

<b>SYMPTOM OBSERVED</b>	<b>POSSIBLE CAUSE</b>	<b>CORRECTIVE ACTION</b>
No operation: * Relay de-energized * No LED's illuminated	No supply power.	Check mains, wiring and/or circuit breaker.
	Fuse blown.	Replace fuse.
No operation: *RCVR FAIL LED is illuminated	Receiver unit failure.	Consult the factory.
Will not calibrate: *PFM FAIL LED is illuminated *CAL FAIL LED is illuminated	PFM input is out of range.	Check PFM input connections. (See PROBE CIRCUIT ELECTRICAL CHECK)
	Unknown.	Consult the factory.
CAL FAIL LED is illuminated after calibration.	Control points were not successfully stored in non-volatile memory.	Repeat calibration procedure.
	Defective printed circuit assembly, PCA.	Consult the factory.
Unit "locked up". *CAL LED's do not illuminate when the CAL pushbuttons are pressed. * Control points do not operate.	Problem in PFM circuit.	Check PFM input connections. (See PROBE CIRCUIT ELECTRICAL CHECK)
	Malfunction induced by RFI from relay contacts with inductive loads.	Install the suppression network, supplied with unit, in parallel with the load.
	Defective printed circuit assembly, PCA.	Consult the factory.
Relay does not operate.	Level not on probe.	Check level.
	Improper calibration.	Repeat calibration procedure.
	Time delay too long.	Reduce time delay period.
	Problem in relay circuit.	Consult the factory.
Erratic relay operation.	Fail-safe switch, SW3-1, not firmly actuated.	Reactivate the switch to make sure that it is firmly actuated.



## 5.2 PROBE CIRCUIT ELECTRICAL CHECK

When probe circuit is indicated, the following procedure should be used to isolate it. A multimeter is needed to perform these tests. Perform the tests in the order given.

MEASUREMENT	READING	REMARKS
Voltage between <b>SIG</b> and <b>GND</b> terminals on TB2. (With PFM transmitter disconnected)	14 to 16 VDC	Normal, proceed
	Less than 14 VDC	Defective receiver, consult the factory.
	More than 16 VDC	
Voltage between <b>S/S</b> and <b>GND</b> terminals on TB2. (With PFM transmitter disconnected)	14 to 16 VDC	Normal, proceed.
	Less than 14 VDC	Defective receiver, consult the factory.
	More than 16 VDC	
Voltage between <b>SIG</b> and <b>GND</b> terminals on TB2. (With PFM transmitter connected)	10 to 15 VDC (may be erratic)	Normal, proceed.
	1 to 9 VDC	Defective transmitter, or connections reversed.
	0 VDC	Connections shorted.
Voltage between <b>S/S</b> and <b>GND</b> terminals on TB2. (With PFM transmitter connected)	10 to 15 VDC	Normal, proceed.
	0 VDC	Connections shorted.
Current between <b>SIG</b> terminal on TB2 and its lead from the transmitter. Note: Meter is in series with the (+) lead and the <b>SIG</b> terminal.	Approximately 4 to 25 maDC (May be erratic and vary with the meter used).	Normal, proceed.
	0 maDC	Interconnecting wiring open.
	Steady 1 to 5 maDC	Abnormal, proceed.
	Steady 17 to 25 maDC	Abnormal, proceed.
Remove transmitter and measure resistance between center probe rod and ground, using highest meter scale. Do not touch the probe or meter leads as your body resistance will change the reading.	Greater than 10 Megohm	Normal, problem is probably a defective transmitter.
	Less than 1 Megohm	Defective probe, or bare probe used in a conductive material.
	1 to 10 Megohms	Leaky probe, probably not causing a problem now, but possible future problem.

## 5.3 BUILT-IN DIAGNOSTICS

The Model 5100 Level-Lance™ has two (2) preprogrammed diagnostic modes. These modes are accessed through positions 8 and 9 of the MODE switch, SW3 (see Figure 4.1 to locate this switch). The following sections describe the use of these two special operational modes.

### 5.3.1 TEST (MODE 8)

This mode is intended to aid in finding hardware problems and provides three (3) functions:

1. Turns the PFM FAIL LED on and off at a predetermined rate.
2. Operates the relay in accordance with the position of the Fail-Safe switch.
3. Operates the "CAL" LED in conjunction with the "CAL HI" and "CAL LO" switches.

#### 5.3.1.1 TIME DELAY TEST

Place the Model 5100 in the TEST mode by placing the MODE switch, SW4, in position #8. Turn on both time delay modes by placing the TIME DELAY enable switches, positions #2 and #3 of SW1, in the "ON" position. Select a zero (00) second time delay by placing both TIME DELAY switches, SW2 and SW3, in the "0" position. The PFM FAIL LED, DS2, should now flash "ON" and "OFF" with each PFM input cycle. If it is possible to change the level in the vessel while the Model 5100 is in this mode the frequency at which the LED flashes should change with the level. The frequency should decrease with a rising level and increase with a falling level.

Now turn off the DELAY LO time delay switch, position #2 of SW1. Also select a non-zero time delay on the TIME DELAY switches, SW2 and SW3. The PFM LED should now flash on and off with the on time determined by the PFM input cycle and the off time determined by the TIME DELAY setting. For example, if the TIME DELAY is set at "05" seconds and the level can be changed the PFM LED should be on for a period of time that varies with the level and an off time fixed at 5 seconds. If the level remains constant and the TIME DELAY setting is varied, the on time should remain constant and the off time should vary in accordance with the delay setting.

Now turn on the DELAY LO switch, position #2 of SW1, and turn off the DELAY HI switch, position #3 of SW1. This should reverse the action of the previous step, the PFM FAIL LED should now be on for a period of time determined by the delay setting and off for a period determined by the PFM input.

For the final test in this series turn on both delays by placing the DELAY HI switch, position #3 of SW1, in the on position. The on and off times for the PFM FAIL LED should now be determined by the delay setting.

To exit the time delay test mode, place both the DELAY LO and DELAY HI switches in the off positions.

#### 5.3.1.2 RELAY OPERATION

In this test sequence the state of the relay is controlled by the position of the FAIL-SAFE switch, position #1 of SW1. When the HIGH LEVEL FAIL-SAFE mode is selected the relay will be de-energized and the relay status LED, DS4, will not be illuminated. When the LOW LEVEL FAIL-SAFE mode is selected the relay will be energized and the relay status LED will be on, green.

#### 5.3.1.3 CALIBRATION SWITCH CHECK

In this test sequence the state of the "CAL" LED, DS2, is determined by the "CAL HI" and "CAL LO" pushbuttons, SW5 and SW6. Whenever either of the pushbuttons is pressed the "CAL" LED should be illuminated and when they are not the LED should be off.

### 5.3.2 CRASH (MODE 9)

This mode is intended to verify the operation of the watchdog timer. If the hardware is functioning properly the CAL PFM FAIL and relay status LED's will be flashing when the unit is in this mode.

**NOTE:**

**When the use of the diagnostic modes is completed be sure to return all switches to their original positions and refer to Section 4 for detailed calibration procedures.**

**SECTION VI**  
**SPARE PARTS**

**6.1 REPLACEMENT PARTS LIST – CONTROLLER**

<b>ROBERTSHAW PART NUMBER</b>	<b>DESCRIPTION</b>	<b>USED ON MODEL NUMBER</b>
044KX202-01	PCA, 18 to 30 VDC With Lights – Without Cover	5100-B1-( ) 5100-D1-( )
044KX267-01	PCA, 18 to 30 VDC With Lights – With Cover	5100-F1-( ) 5100-H1-( )
044KX202-02	PCA, 115 VAC With Lights – Without Cover	5100-B2-( ) 5100-D2-( )
044KX267-02	PCA, 115 VAC With Lights – With Cover	5100-F2-( ) 5100-H2-( )
044KX202-03	PCA, 230 VAC With Lights – Without Cover	5100-B3-( ) 5100-D3-( )
044KX267-03	PCA, 230 VAC With Lights – With Cover	5100-F3-( ) 5100-H3-( )
044KX202-04	PCA, 18 to 30 VDC Without Lights – Without Cover	5100-A1-( ) 5100-C1-( )
044KX267-04	PCA, 18 to 30 VDC Without Lights – With Cover	5100-E1-( ) 5100-G1-( )
044KX202-05	PCA, 115 VAC Without Lights – Without Cover	5100-A2-( ) 5100-C2-( )
044KX267-05	PCA, 115 VAC Without Lights – With Cover	5100-E2-( ) 5100-G2-( )
044KX202-06	PCA, 230 VAC Without Lights – Without Cover	5100-A3-( ) 5100-C3-( )
044KX267-06	PCA, 230 VAC Without Lights – With Cover	5100-E3-( ) 5100-G3-( )
130KB040-01	Fuse, TD, 5 mm x 20 mm, ¼ Amp (AC Units)	5100-( )2-( ) 5100-( )3-( )
130KB040-02	Fuse, TD, 5 mm x 20 mm, ½ Amp (DC Units)	5100-( )1-( )
190KB006-04	Lamp, 6S6DC, 30V, 6W, Clear	ALL
250KB066	Relay, DPDT, 12 VDC Coil	ALL
270KB906	IC, Controller, Programmed	ALL
285KB069-03	Plug, Screw Terminal, Front Connection, 3 Position (TB2, Transmitter Input)	ALL
285KB069-09	Plug, Screw Terminal, Front Connection, 9 Position (TB1, Power and Relay)	ALL
909GM170	Kit, Arc Suppression	ALL

## 6.2 REPLACEMENT PARTS LIST – PFM TRANSMITTER

PART NUMBER	DESCRIPTION	USED ON MODEL NUMBER
044KX029	Short-stop™ Transmitter PCA (With Bracket)	5100-( ) ( )-C 5100-( ) ( )-D 5100-( ) ( )-G 5100-( ) ( )-H
044KX230	Standard Transmitter PCA (With Bracket)	5100-( ) ( )-A 5100-( ) ( )-B 5100-( ) ( )-E 5100-( ) ( )-F
909GM079	Kit, Probe Pin	ALL

**Robertshaw**

**Industrial Products Division**

**U.S.A. and Canada**

Robertshaw Industrial Products Division

1602 Mustang Drive

Maryville, TN 37801

Telephone: (865) 981-3100 Fax: (865) 981-3168

<http://www.robertshaw.thomasregister.com>

<http://www.robertshawindustrial.com>

**Exports**

Invensys Appliance Controls

1701 Byrd Ave.

P.O. Box 26544

Richmond, Virginia 23261-6544

Telephone: (804) 756-6500 Fax: (804) 756-6561



Q-4004 (2/04) Printed in U.S.A.