

The **Universal Low Pressure (U3)** check valve is a one piece body machined from bar stock and is designed for minimum pressure drop. The valve has a light weight compact design that provides maintenance-free, dependable service. Threads are per ASME B1.20.1. Also available with ISO 7 “Rp” threads. (UR)

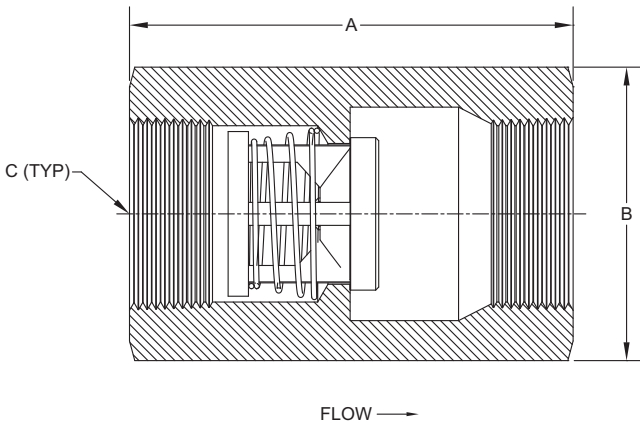

| Nom. Pipe Size | Size Code | A | Hex ^① Size B | C ^② | Orifice Diameter |
|----------------|-----------|------|-------------------------|----------------|------------------|
| 3/8 | C | 2.16 | 13/16 | 3/8 NPT | 0.348 |
| 1/2 | D | 2.71 | 1-1/8 | 1/2 NPT | 0.464 |
| 3/4 | F | 2.95 | 1-1/4 | 3/4 NPT | 0.593 |
| 1 | H | 3.64 | 1-5/8 | 1 NPT | 0.890 |
| 1-1/4 | I | 3.91 | 2-1/4 | 1-1/4 NPT | 1.135 |
| 1-1/2 | J | 4.36 | 2-1/2 | 1-1/2 NPT | 1.385 |
| 2 | K | 5.85 | 3 | 2 NPT | 1.555 |
| 2-1/2 | L | 5.50 | 3-3/4 | 2-1/2 NPT | 1.555 |
| 3 | M | 6.25 | 4-1/2 | 3 NPT | 2.025 |
| 4 | N | 7.13 | 5-1/2 | 4 NPT | 2.560 |

^① May be larger and/or round.

^② Consult factory for ISO 7 “Rp” threads.

| Body Material ^③ | Availability | Non-Shock Pressure-Temperature Rating | |
|----------------------------|--|---|-------------------|
| 316 Stainless Steel (SS) | Standard | 3/8 - 3 | 4 |
| Carbon Steel (CS) | | | |
| Brass (BR) | | | |
| Alloy 20 (A2) | Semi-standard | 3000 PSIG @ 100°F (1500 PSIG for o-ring seats) | 1500 PSIG @ 100°F |
| Alloy C-276 (HC) | | | |
| Monel® (MO) | | | |
| Alloy B (HB) | Contact the factory for these or other materials | | |
| Titanium (TI) | | | |

^③ See page 55 for material grade information.

Universal Low Pressure
For Water at 72°F

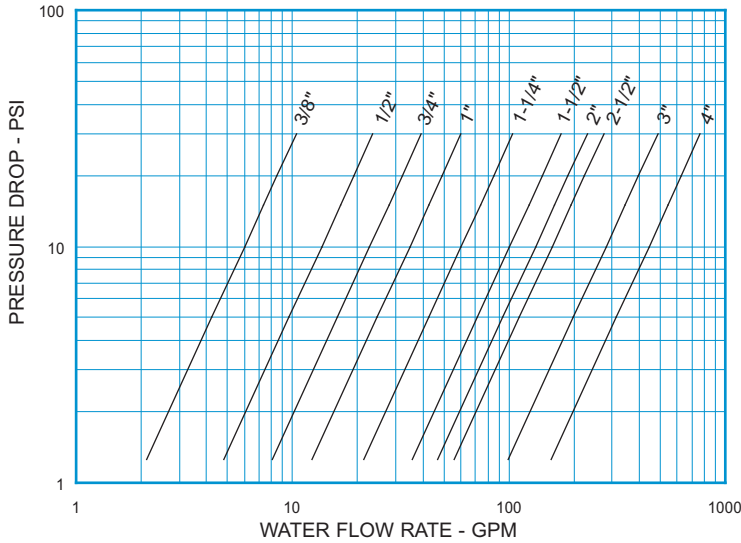

Note: All flow curves and Cv values presume the valves are fully open with 1/2 PSI cracking pressure springs. Consult the factory for more information.

| STYLE U3 (UN-3) C _v VALUES & VALVE WEIGHTS | | | |
|--|-------|----------------|----------|
| C _v | SIZE | SS & CS ALLOYS | BRASS |
| 1.9 | 3/8 | 3.0 oz. | 3.3 oz. |
| 4.3 | 1/2 | 8.5 oz. | 9.1 oz. |
| 7.2 | 3/4 | 9.6 oz. | 10.1 oz. |
| 11.0 | 1 | 1.2 lb. | 1.3 lb. |
| 19.0 | 1-1/4 | 2.9 lb. | 3.2 lb. |
| 31.9 | 1-1/2 | 3.6 lb. | 3.9 lb. |
| 42.0 | 2 | 6.5 lb. | 7.2 lb. |
| 50.0 | 2-1/2 | 9.2 lb. | 10.0 lb. |
| 89.0 | 3 | 14.3 lb. | 15.5 lb. |
| 140 | 4 | 21.5 lb. | 23.3 lb. |

See page 50 for Flow Formulae.
Valve weights are approximate.

HOW TO ORDER
CHECK-ALL STYLE U3 (UN-3)

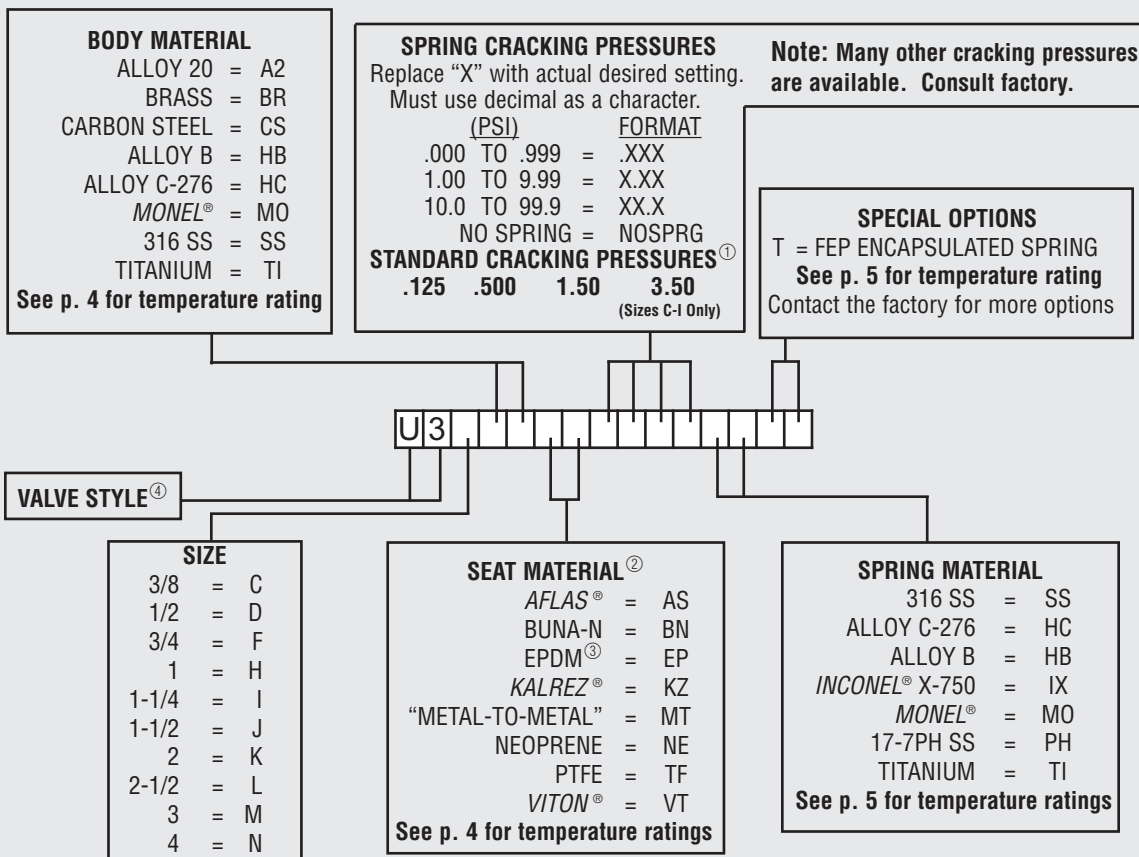

Listed above are the most common material selections. Please contact the factory for additional options.

- ① .500 PSI is the only standard cracking pressure for spring materials other than Stainless Steel. Cracking pressure tolerance is +/- 15%. .125 PSI springs are not recommended for installations with flow vertical down.
- ② Seat materials other than "metal-to-metal" have a maximum pressure rating of 1500 PSI. "Metal-to-Metal" and PTFE seats are not resilient. See page 51 for allowable leakage rates.
- ③ EP seats not recommended for use with Carbon Steel valves.
- ④ Use "UR" for valves with ISO 7 "Rp" threads.