

- ±0.25% Test Gauge Accuracy
- 316L Stainless Steel Wetted Parts
- 1.5" or 2.0" Tri-Clamp®

- Easy One Button Operation
- Selectable Units
- Store Minimum and Maximum Readings

- Food Processing
- Dairy and Breweries
- Pharmaceutical

Specifications

Ranges and Resolution

See table below for standard ranges and units
See table on next page for available engineering units
Resolution is fixed for each engineering unit

Accuracy

Accuracy includes linearity, hysteresis, repeatability
Accuracy: ±0.25% of full scale ±1 least significant digit
Sensor hysteresis: ±0.015% FS, included in accuracy
Sensor repeatability: ±0.01% FS, included in accuracy

Display

3 readings per second nominal display update rate
4 digit LCD, 0.5" H and 5 character 0.25" H alphanumeric
Red LED backlight active for 1 minute

Batteries, Battery Life, Low Battery Indication

2 AA alkaline
Up to 1500 hours depending on backlight usage
Low battery symbol on display

Auto Shutoff

User selectable 1 minute to 8 hours or front button on/off
Factory default 5 minutes, unless other time is specified

Controls and Functions

Front button: on/off, view/clear min/max memory
Hold at power-on to zero gauge reference models

Memory

Minimum and/or maximum readings stored in memory
Readings cleared or stored at shutoff
User configurable.

Setup and Calibration

Pass code protected internal buttons for setup and calibration
Non-interactive zero, span, and linearity, ±10% of range

Sanitary Seal

3-A certified Tri-Clamp flush diaphragm sanitary seal
NEOBEE® M-20 fill
All 316L stainless steel construction
Optional electropolish passivation

Weight (approximate)

1.5" gauge: 2 lbs shipping: 3 lbs
2.0" gauge: 2.5 lbs shipping: 3.5 lbs

Housing and Materials

NEMA 4X ABS/polycarbonate case, polycarb. label, rear gasket
Conformal coating on circuit boards for moisture resistance.

Maximum Working Pressure

1.5": 2 X pressure range or 600 psi, whichever is less
2.0": 2 X pressure range or 550 psi for 300 psi sensor
Maximum pressure dependent on type of clamping device
112.5% FS out-of-range display: |---- or |-----

Environmental

Storage temperature: -40 to 203°F (-40 to 95°C)
Operating temperature: -4 to 185°F (-20 to 85°C)
Compensated temperature: 32 to 158°F (0 to 70°C)
Thermal effect due to fill: Up to 1.2 psi from 0 to 70°C
Positional effect: Up to 0.14 psi

Quick Link: cecomp.com/san



NEMA 4X Housing

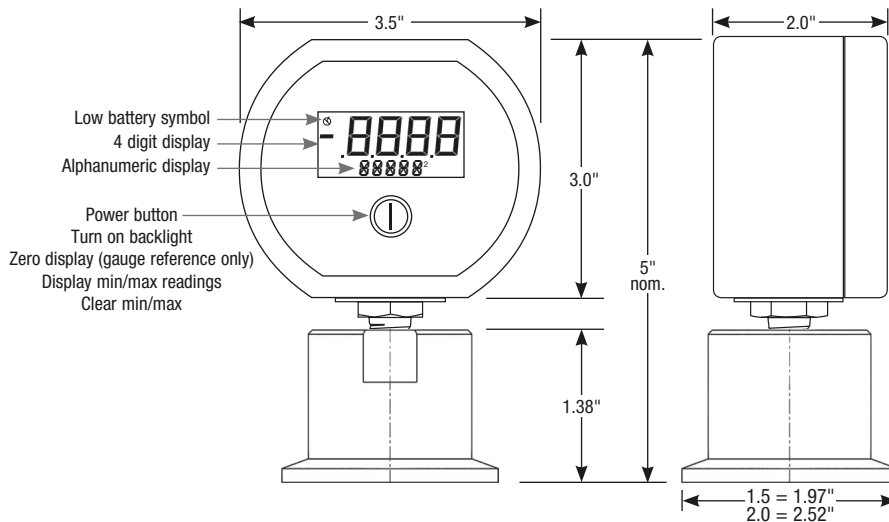

Default Range and Units See next page for additional units	Vacuum Service	1" or 1.5" Tri-Clamp	Max. psi*	2" Tri-Clamp	Max. psi*
-14.70 to 15.00 psig	Yes	DSGB115N±15PSIG	30 psig	DSGB120N±15PSIG	30 psig
-29.9 inHg to 15.0 psig	Yes	DSGB115N30V15PSIG	30 psig	DSGB120N30V15PSIG	30 psig
15.00 to 0 psi absolute	Yes	DSGB115N15PSIA	30 psig	DSGB120N15PSIA	30 psig
0 to 14.70 psig vacuum	Yes	DSGB115N15PSIGVAC	30 psig	DSGB120N15PSIGVAC	30 psig
0 to 15.00 psig	Yes	DSGB115N15PSIG	30 psig	DSGB120N15PSIG	30 psig
30.00 to 0 psi absolute	Yes	DSGB115N30PSIA	60 psig	DSGB120N30PSIA	60 psig
0 to 30.00 psig	No	DSGB115N30PSIG	60 psig	DSGB120N30PSIG	60 psig
0 to 60.00 psig	No	DSGB115N60PSIG	120 psig	DSGB120N60PSIG	120 psig
100.0 to 0 psi absolute	Yes	DSGB115N100PSIA	200 psig	DSGB120N100PSIA	200 psig
-29.9 inHg to 100.0 psig	Yes	DSGB115N30V100PSIG	200 psig	DSGB120N30V100PSIG	200 psig
0 to 100.0 psig	Yes	DSGB115N100PSIG	200 psig	DSGB120N100PSIG	200 psig
-29.9 inHg to 200.0 psig	Yes	DSGB115N30V200PSIG	400 psig	DSGB120N30V200PSIG	400 psig
0 to 200.0 psig	Yes	DSGB115N200PSIG	400 psig	DSGB120N200PSIG	400 psig
0 to 300.0 psig	No	DSGB115N300PSIG	600 psig	DSGB120N300PSIG	550 psig

Option—add to end of model number	
-E	Electropolished sanitary fitting
Calibration certificates—order separately	
CD	Calibration data, 5 test points, test date
NC	NIST certificate with traceability documentation, 5 test points and date

*Maximum pressure dependent on type of clamping device

NEOBEE—Reg TM Stepan Specialty Products, LLC
Tri-Clamp—Reg TM Alfa Laval Inc.

Ranges and Selectable Units

Range Codes

The range code in the gauge model number indicates the default range when the gauge is ordered. Any listed engineering unit may be ordered as the default.

Selectable Ranges

Engineering units may be changed to any of those listed in the same group as shown in the table below.

Conversion

Engineering unit conversions are calculated from the factory default unit to the newly selected units.

Range Codes	Selectable Units	Range Codes	Selectable Units	Range Codes	Selectable Units	Range Codes	Selectable Units
15PSIA	15.00 to 0 psia	±15PSIG	-15.00 to 15.00 psig	60PSIG	0 to 60.00 psig	-15V100PSIG	-15.0 to 100.0 psig
30INHGA	30.00 to 0 inHg abs	-30INHG/15PSIG	-30.00 inHg to 15.00 psig	120INHGG	0 to 120.0 inHg	-30INHG/100PSIG	-30.0 inHg to 100.0 psig
400INH2OA	400.0 to 0 inH2O abs	±30INHGG	-30.00 to 30.00 inHg	1660INH2OG	0 to 1660 inH2O	-30V200INHGG	-30.0 to 200.0 inHg
240ZINA	240.0 to 0 oz/in ² abs	±400INH2OG	-400 to 400 inH2O	960ZING	0 to 960 oz/in ²	-400V2770INH2OG	-400 to 2770 inH2O
1000GCGMA	1000 to 0 g/cm ² abs	±240ZING	-240.0 to 240.0 oz/in ²	4200GCMG	0 to 4200 g/cm ²	240V1600ZING	-240 to 1600 oz/in ²
760MMHGA	760.0 to 0 mmHg abs	±1000GCMG	-1000 to 1000 g/cm ²	3100MMHGG	0 to 3100 mmHg	760V5200MMHGG	-760 to 5200 mmHg
760TORRA	760.0 to 0 torr abs	±760MMHGG	-760 to 760 mmHg	3100TORRR	0 to 3100 torr	760V5200TORRR	-760 to 5200 torr
1000MBARA	1000 to 0 mbar abs	±760TORRR	-760 to 760 torr	4100MBARG	0 to 4100 mbar	-100V700KPAG	-100 to 700 kPa
1000CMH2OA	1000 to 0 cmH2O abs	±1000MBAR	-1000 to 1000 mbar	4200CMH2OG	0 to 4200 cmH2O	-0.1V0.7MPAG	-0.100 to .700 MPa
100KPAA	100.0 to 0 kPa abs	±1000CMH2OG	-1000 to 1000 cmH2O	140FTH2O	0 to 140.0 ftH2O	-1V7BARG	-1.00 to 7.00 bar
0.1MPAA	.1000 to 0 MPa abs	±100KPAG	-100.0 to 100.0 kPa	400KPAG	0 to 400.0 kPa	-1V7KCGMG	-1.00 to 7.00 kg/cm ²
1BARA	1.000 to 0 bar abs	±0.1MPAG	-1.000 to .1000 MPa	0.4MPAG	0 to .4000 MPa	-1V7ATMG	-1.00 to 7.00 atm
1KGCMA	1.000 to 0 kg/cm ² abs	±1BARG	-1.000 to 1.000 bar	4BARG	0 to 4.000 bar		
1ATMA	1.000 to 0 atm abs	±1KGCMG	-1.000 to 1.000 kg/cm ²	4KCGMG	0 to 4.000 kg/cm ²		
		±1ATMG	-1.000 to 1.000 atm	4ATMG	0 to 4.000 atm		
Range Codes	Selectable Units	Range Codes	Selectable Units	Range Codes	Selectable Units	Range Codes	Selectable Units
15PSIVAC	0 to 15.00 psig vac	30PSIA	30.00 to 0 psia	100PSIA	100.0 to 0 psia	-15V200PSIG	-15.0 to 200.0 psig
30INHGVAC	0 to 30.00 inHg vac	60INHGA	60.00 to 0 inHg abs	200INHGA	200.0 to 0 inHg abs	-30INHG/200PSIG	-30.0 inHg to 200.0 psig
400INH2OVAC	0 to 400 inH2O vac	850INH2OA	850 to 0 inH2O abs	2770INH2OA	2770 to 0 inH2O abs	-30V400INHGG	-30.0 to 400.0 inHg
240ZINVAC	0 to 240.0 oz/in ² vac	480ZINA	480.0 to 0 oz/in ² abs	1600ZINA	1600 to 0 oz/in ² abs	400V5500INH2OG	-400 to 5500 inH2O
1000GCMVAC	0 to 1000 g/cm ² vac	2100GCGMA	2100 to 0 g/cm ² abs	7000GCGMA	7000 to 0 g/cm ² abs	240V3200ZING	-240 to 3200 oz/in ²
760MMHGVAC	0 to 760.0 mmHg vac	1600MMHGA	1600 to 0 mmHg abs	5200MMHGA	5200 to 0 mmHg abs	-100V1400KPAG	-100 to 1400 kPa
760TORRVAC	0 to 760.0 torr vac	1600TORRA	1600 to 0 torr abs	5200TORRA	5200 to 0 torr abs	-0.1V1.4MPAG	-0.100 to 1.400 MPa
1000MBARVAC	0 to 10000 mbar vac	2000MBARA	2000 to 0 mbar abs	7000MBARA	7000 to 0 mbar abs	-1V14BARG	-1.00 to 14.00 bar
1000CMH2OVAC	0 to 10000 cmH2O vac	2100CMH2OA	2100 to 0 cmH2O abs	7000CMH2OA	7000 to 0 cmH2O abs	-1V14KCGMG	-1.00 to 14.00 kg/cm ²
100KPAVAC	0 to 100.0 kPa vac	200KPAA	200.0 to 0 kPa abs	700KPAA	700.0 to 0 kPa abs	-1V 14ATMG	-1.00 to 14.00 atm
0.1MPAVAC	0 to .1000 MPa vac	0.2MPAA	0 to .2000 to 0 MPa abs	0.7MPAA	0 to .7000 to 0 MPa abs		
1BARVAC	0 to 1.000 bar vac	2BARA	0 to 2.000 to 0 bar abs	7BARA	0 to 7.000 to 0 bar abs		
1KGCMVAC	0 to 35.00 kg/cm ² vac	2KGCMA	0 to 2.000 to 0 kg/cm ² abs	7KGCMA	0 to 7.000 to 0 kg/cm ² abs		
1ATMVAC	0 to 1.000 atm vac	2ATMA	0 to 2.000 to 0 atm abs	7ATMA	0 to 7.000 to 0 atm abs		
Range Codes	Selectable Units	Range Codes	Selectable Units	Range Codes	Selectable Units	Range Codes	Selectable Units
15PSIG	0 to 15.00 psig	30PSIG	0 to 30.00 psig	100PSIG	0 to 100.0 psig	200PSIG	0 to 200.0 psig
30INHGG	0 to 30.00 inHg	60INHGG	0 to 60.00 inHg	200INHGG	0 to 200.0 inHg	400INHGG	0 to 400.0 inHg
400INH2OG	0 to 400.0 inH2O	850INH2OG	0 to 850 inH2O	2770INH2OG	0 to 2770 inH2O	5500INH2OG	0 to 5500 inH2O
240ZING	0 to 240.0 oz/in ²	480ZING	0 to 480.0 oz/in ²	1600ZING	0 to 1600 oz/in ²	3200ZING	0 to 3200 oz/in ²
1000GCMG	0 to 1000 g/cm ²	2100GCMG	0 to 2100 g/cm ²	7000GCMG	0 to 7000 g/cm ²	480FTH2O	0 to 480.0 ftH2O
760MMHGG	0 to 760.0 mmHg	1600MMHGG	0 to 1600 mmHg	5200MMHGG	0 to 5200 mmHg	1400KPAG	0 to 1400 kPa
760TORRR	0 to 760.0 torr	1600TORRR	0 to 1600 torr	5200TORRR	0 to 5200 torr	1.4MPAG	0 to 1.400 MPa
1000MBARG	0 to 1000 mbar	2000MBARG	0 to 2000 mbar	7000MBARG	0 to 7000 mbar	14BARG	0 to 14.00 bar
1000CMH2OG	0 to 1000 cmH2O	2100CMH2OG	0 to 2100 cmH2O	7000CMH2OG	0 to 7000 cmH2O	14KCGMG	0 to 14.00 kg/cm ²
35FTH2O	0 to 35.00 ftH2O	70FTH2O	0 to 70.00 ftH2O	230FTH2O	0 to 230.0 ftH2O	14ATMG	0 to 14.00 atm
100KPAG	0 to 100.0 kPa	200KPAG	0 to 200.0 kPa	700KPAG	0 to 700.0 kPa		
0.1MPAG	0 to .1000 MPa	0.2MPAG	0 to .2000 MPa	0.7MPAG	0 to .7000 MPa		
1BARG	0 to 1000 bar	2BARG	0 to 2.000 bar	7BARG	0 to 7.000 bar		
1KGCMG	0 to 1000 kg/cm ²	2KCGMG	0 to 2.000 kg/cm ²	7KCGMG	0 to 7.000 kg/cm ²		
1ATMG	0 to 1000 atm	2ATMG	0 to 2.000 atm	7ATMG	0 to 7.000 atm		

Installation Precautions

- ✓ Read these instructions before using the gauge. Configuration may be easier before installation. Contact the factory for assistance.
- ✓ These products do not contain user-serviceable parts. Contact us for repairs, service, or refurbishment.
- ✓ Gauges must be operated within specified ambient temperature ranges.
- ✓ Use a pressure or vacuum range appropriate for the application.
- ✓ Use clamp appropriate for the pressure range of the gauge.
- ✓ Remove system pressures before removing or installing gauge.
- ✓ Good design practice dictates that positive displacement liquid pumps include protection devices to prevent sensor damage from pressure spikes, acceleration head, and vacuum extremes.
- ✗ Avoid permanent sensor damage! Do not apply vacuum to non-vacuum gauges or hydraulic vacuum to any gauges.
- ✗ Avoid permanent damage! NEVER touch surface of diaphragm.
- △ Gauges are not for oxygen service. Accidental rupture of sensor diaphragm may cause oil inside seal to react with oxygen.

Types of Gauges

Bipolar ranges read positive pressure and vacuum in the same units, and zero with the gauge port open. Absolute reference gauges read zero at full vacuum and atmospheric pressure with the gauge port open. With an open gauge port the readings will vary continuously due to the effects of barometric pressure.

Selectable Ranges

Range Codes
The range code is part of the gauge model number and indicates the default range when the gauge is ordered.

Selectable Ranges
Engineering units may be changed to any of those listed in the same sensor range as shown in the range table.

Conversion
Engineering units are calculated from the factory default unit to the newly selected units. The ranges listed under the psi sensor range are rounded off.

Battery Replacement

A low battery indication will be shown in the upper left-hand corner of the display when the battery voltage falls sufficiently. The batteries should be replaced soon after the indicator comes on or unreliable readings may result.

1. Remove the 6 Phillips screws on the back of the unit.
2. Remove the battery retainer. Remove batteries by lifting up the positive end of the battery (opposite the spring) taking care not to bend the battery holder spring.
3. Discard old batteries properly, do not discard into fire, sources of extreme heat, or in any hazardous manner.
4. Always replace both batteries at the same time with high quality alkaline batteries.
5. Install batteries with correct orientation. Incorrect polarity will damage the gauge. The negative (flat) end of each battery should be inserted first facing the battery holder spring.
6. Replace battery retainer and back cover, including the rubber gasket and reinstall the six screws.

Operation

Function	Button	Prompt (Release Button)
On	Press for 1 second	Display test > default units > selected units FULL SCALE > display test > actual reading
Zero (gauge ref. only)	Press and hold	Display test > >>>> default units > selected units FULL SCALE > display test > actual reading
Hi reading	Press/hold	MAX > max. reading & units
Lo reading	Press/hold	MIN > min. reading & units
Exit Hi/Lo	Press/hold	*** > actual reading
Clear Hi/Lo	Press/hold	MAX > CLR MAX/MIN > actual reading
Clear, off	Press/hold	MAX > CLR MAX/MIN > OFF

Power-Up

Press and hold the front button for approximately 1 second. The display is tested, the default full-scale range is indicated, the full-scale range in the selected units are indicated, the display is tested again, then the actual pressure and units are displayed.

Power-Up With Zero

This applies to gauge reference models only. Absolute reference gauges do not use the zero feature since they read atmospheric pressure under normal conditions.

Be sure the gauge port is exposed to normal atmospheric pressure and no pressure is applied. The zeroing function is only activated at each power-up and the stored zero correction is erased when the gauge is shut off.

Press and hold the front button. The display is tested and then 0000 is displayed. The gauge is now zeroed. Release the button and the full-scale range in the selected units are indicated, the display is

Operation—continued

tested again, then the actual pressure and units are displayed.

Attempting to zero the gauge with pressure greater than approximately 3% of full-scale pressure or vacuum applied will result in an error condition, and the display will alternately indicate Err 0 and the actual measured pressure. The gauge must be powered down to reset the error condition.

Normal Operation

Following the start-up initialization, the display indicates the pressure reading updated approximately 3 times per second. The auto shutoff timer starts when the gauge is powered up or whenever the button is pushed, unless the gauge shutoff time was set to zero for on/off operation.

If excessive vacuum is applied to a pressure-only gauge, the display will indicate -Err until the vacuum is released. Applying vacuum to a gauge designed for pressure may damage the pressure sensor.

If excessive pressure is applied (112.5% over range), an out-of-range indication of 1 --- or 1.-- will be displayed depending on model.

Display Backlighting

Display backlighting can be turned on by momentarily pressing the front button whenever the gauge is on. The backlighting will turn on for one minute and then automatically shut off. This also restarts the auto shutoff timer. The display backlighting will not be apparent under bright lighting conditions.

Minimum and Maximum Readings

Gauges are normally configured with minimum and maximum capture functions enabled. One or both can be disabled in the Advanced Configuration mode.

Minimum and maximum readings are continuously stored and updated whenever the gauge is on. The stored readings can be manually cleared if desired. The MAX and MIN memory is also cleared whenever the gauge is off unless configured to save the readings.

Press and hold the button for about 1 second until MAX is displayed alternating with the units. The maximum reading will be continuously updated. The gauge may be left in this mode.

After MAX is displayed, press and hold the button for about 1 second until MIN is displayed alternating with the units. The minimum reading will be continuously updated. The gauge may be left in this mode. If excessive vacuum is applied to a pressure-only gauge while in this mode, the display will indicate -Err until the MAX/MIN readings are cleared.

After MIN is displayed, press and hold the button again for about 1 second until * * * * is displayed. The MAX and MIN memory is not erased and the gauge returns to normal operation with the display indicating the current reading.

Press and continue to hold the button until the display indicates CLR MX/MN (about 3 seconds total) and then release the button. Both maximum and minimum values are cleared and the gauge returns to the normal mode and displays the current pressure.

Shut-Down

To shut off the gauge manually at any time, press and hold the button until the display indicates OFF (about 5 seconds) and then release.

When an auto shutoff timer is used, the display indicates OFF five seconds prior to auto shutoff. The button can be pressed to keep the gauge on. The auto shutoff and backlight (if equipped) timers are reset whenever the button is pressed and released.

If the gauge set up without auto shutoff (on/off operation) it will stay on until manually shut off or until the batteries are depleted. Turn gauge off when not in use to conserve battery life.

Basic Configuration

Engineering Unit Selection

Engineering unit selection is done via internal buttons to help prevent accidental or unauthorized changes. The selected engineering unit is stored in non-volatile memory and will be retained even with the gauge off or batteries removed. The available engineering units depend on the sensor range and display resolution.

Compound (inHg/PSIG) gauges must be changed to display single-unit vacuum/pressure readings in the Advanced Configuration mode before different engineering units can be selected.

The default engineering units are mathematically converted to the newly selected engineering unit. When the gauge is powered up, the originally configured range is displayed and then the conversion with the selected engineering unit is displayed.

To change engineering units remove the rear cover to gain access to the two internal buttons located near the lower right and left corners of the circuit board.

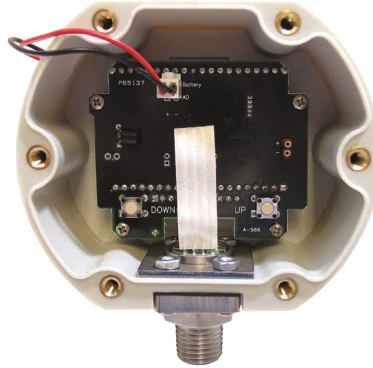

With the gauge powered up, press and hold the UP button. Release the button when the engineering units begin to flash.

Use the UP and DOWN buttons to scroll through the list of engineering units available for the pressure range of the sensor.

When the desired units are displayed, press and release the front button to save the selection and return to normal operation.

Note: The gauge will automatically revert to normal operation if no buttons are operated for approximately 15 seconds.

Replace the rear cover and gasket taking care not to pinch the power wires between the cover and the case.

Auto Shutoff Time Selection

Auto shutoff time selection is done via internal buttons to help prevent accidental or unauthorized changes. The selected shut off time is stored in non-volatile memory and will be retained even with the battery off or batteries removed.

Remove the rear cover to gain access to the two internal buttons located near the lower right and left corners of the circuit board.

With the gauge powered up, press and hold the DOWN button. Release the button when the auto shutoff time is displayed on the upper display.

The lower display will indicate AST M if the time displayed is in minutes, and AST H if it is in hours.

An auto shutoff time of 0 signifies that the auto shutoff feature is disabled and the front button turns the gauge on and off.

Use the UP and DOWN buttons to select 0, 1, 2, 5, 10, 15, 20 or 30 minutes, or 1, 2, 4, or 8 hours.

When the desired time is displayed, press and release the front button to save the selection and return to normal operation.

Note: The gauge will automatically revert to normal operation if no buttons are operated for approximately 15 seconds.

Replace the rear cover taking care not to pinch the power wires between the cover and the case.

Advanced Configuration

Advanced configuration requires a pass code for access and allows more features to be configured.

Remove the rear cover to gain access to the buttons located near the lower right and left corners of the circuit board.

With the gauge off, press and hold the UP button. Then press the front button. Release all buttons when the display indicates CFG and the program version then the full-scale range is indicated and the display is tested.

The display then indicates _ _ _ _ with the first underscore blinking, and with CFGPC (configuration pass code) on the character segments.

Note: The gauge will automatically revert to normal operation if no buttons are operated for approximately 15 seconds. To cancel and return to normal operation, press and release the front button without entering any pass code characters.

Pass Code Entry

The factory default is 3510, but this may be changed by the user under the Pass Code Configuration section.

1. Use the UP or DOWN buttons to set the left-most digit to 3.
2. Press and release the front button to move to the next position. The 3 will remain, and the second position will be blinking.
3. Use the UP or DOWN buttons to select 5.
4. Press and release the front button to index to the next position. 35 will remain, and the third position will be blinking.
5. Use the UP or DOWN buttons to select 1.
6. Press and release the front button to index to the next position. 351 will remain, and the fourth position will be blinking.
7. Use the UP or DOWN buttons to select 0.
8. Press and release the front button to proceed with configuration procedures.

If an incorrect pass code is entered, the gauge will return to the start of the pass code entry sequence.

Factory/User Configuration

The upper display section will be blank, and the lower section will display either USER_ or FCTRY.

If USER_ is selected, the user configuration can be modified as described in the following steps.

To select USER_, press and release the DOWN button.

The lower display will indicate USER_.

Press and release the front button to continue.

If FCTRY is selected, the existing user configuration will be replaced by the original factory configuration.

To select FCTRY, press and release the UP button.

The lower display will indicate FCTRY.

Press and release the front button to restore the factory configuration and restart the gauge.

Max/Min Configuration

Use the UP and DOWN buttons to select from the following:

- MX/MN Both highest and lowest values will be captured
- MX/--- Only highest value will be captured
- /MN Only lowest value will be captured
- /-/--- Capture feature is disabled

Press and release the front button to move to the next parameter.

Max/Min Memory

The upper display section will indicate CLR.

Use the UP and DOWN buttons to select from the following:

- AUTO Automatically clear max. and min. values when the gauge is powered off
 - MAN Manually clear max. and min. values
- Press and release the front button to move to the next parameter.

Gauge Type Configuration

This will only appear with 15, 100, or 200 psig ranges that were originally ordered as compound gauges.

Use the UP and DOWN buttons to select from the following:

- /+EU Vacuum is indicated as negative pressure in the selected engineering units
- CMPND Vacuum is negative INHG, pressure is PSIG. This setting will disable engineering unit selection.

Press and release the front button to save the user configuration and restart the gauge.

Replace the rear cover taking care not to pinch the power wires between the cover and the case.

Calibration Preparation

Gauges are calibrated at the factory using equipment traceable to NIST. Gauges are calibrated in an upright position at normal ambient temperatures (approx. 20°C). There is no need to calibrate the gauge before putting it into service unless the process temperature and gauge position deviate from normal.

Calibration should only be performed by qualified individuals using appropriate calibration standards and procedures. Calibration intervals depend on your quality control program requirements, although many customers calibrate annually.

The calibration system must be able to generate and measure pressure/vacuum over the full range of the gauge and should be at least four times more accurate than the gauge being calibrated.

A vacuum pump able to produce a vacuum of 100 microns (0.1 torr or 100 millitorr) or lower is required for vacuum gauges. Warning: application of vacuum to non-vacuum models will result in damage to the sensor.

Allow the gauge to acclimate to the calibration temperature for at least 60 minutes. Calibrate the gauge at the same temperature as the process with the gauge oriented in the same position.

Install fresh batteries before calibration.

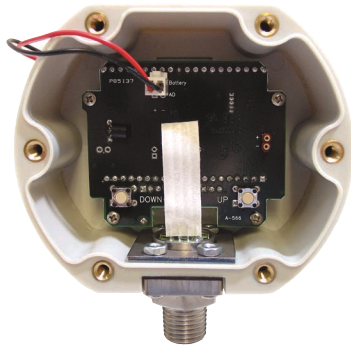

Calibration

Entering Calibration Mode

With the gauge off, press and hold the DOWN button. Then press the front button. Release all buttons when the display indicates CAL.

The display begins by indicating the full-scale positive pressure rating of the gauge in the engineering units as configured by the factory, and then shows all display.

Before the gauge enters the Calibration Mode, the display initially indicates ____ with the first underscore blinking, and with CALPC (calibration pass code) on the lower display.

Note: The gauge will automatically revert to normal operation if no buttons are operated for approximately 15 seconds. To cancel and return to normal operation, press and release the front button without entering any pass code characters.

Enter the User-Modifiable Pass Code

The factory default is 3510, but this is user changeable.

1. Use the UP or DOWN buttons to set the left-most digit to 3.
2. Press and release the front button to move to the next position. The 3 will remain, and the second position will be blinking.
3. Use the UP or DOWN buttons to select 5.
4. Press and release the front button to index to the next position. 35 will remain, and the third position will be blinking.
5. Use the UP or DOWN buttons to select 1.
6. Press and release the front button to index to the next position. 351 will remain, and the fourth position will be blinking.
7. Use the UP or DOWN buttons to select 0.
8. Press and release the front button to proceed with configuration procedures.

If an incorrect pass code is entered, the gauge will return to the start of the pass code entry sequence.

Calibration Mode

The gauge enters and remains in the calibration mode until restarted manually or power is removed. Features not related to calibration are disabled and compound range models are set for the same engineering units for pressure and for vacuum.

The calibration may be performed in any of the available engineering units as well as percent (PCT). For greatest accuracy, use the UP and DOWN buttons to select engineering units for calibration with highest resolution (highest number of display counts). Press and release the front button when the appropriate engineering units are

Calibration—continued

displayed. Suggested units are listed below.

Sensor	Suggested units for calibration
15 PSI	775.7 MMHG (TORR)
30 PSI	61.08 INHG
50 PSI	50.00 PSI
60 PSI	60.00 PSI
100 PSI	7.031 KG/CM2
200 PSI	407.2 INHG
300 PSI	610.8 INHG
Any	100.00 PCT (percent)

The display will then indicate the currently applied pressure in the engineering units selected for calibration.

UP and DOWN Button Operation

Each time one of the calibration buttons is pressed and released quickly, a small change is made to the digitized pressure signal. It may take more than one of these small changes to result in a single digit change on the display.

To make larger changes, press and hold the appropriate calibration button. After about one second, the display will begin to change continuously. Release the button to stop. Then make fine adjustments by pressing and quickly releasing the calibration buttons as previously described.

Gauge Reference Pressure Gauges

Apply zero pressure by venting the gauge port to atmosphere. The character display will alternate between ZERO and CAL. Adjust for a display indication of zero using the UP and the DOWN buttons.

Apply full-scale pressure. The character display will alternate between +SPAN and CAL. Adjust for a display indication of full-scale pressure using the UP and the DOWN buttons.

Apply 50% full-scale pressure. The character display will alternate between +MID and CAL. Adjust for a display indication equal to 50% of full-scale pressure using the UP and the DOWN buttons.

Gauge Reference Vacuum Gauges

Apply zero pressure by venting the gauge port to atmosphere. The character display will alternate between ZERO and CAL. Adjust for a display indication of zero using the UP and the DOWN buttons.

Apply full-scale vacuum. The character display will alternate between +SPAN and CAL. Adjust for a display indication of full-scale vacuum using the UP and the DOWN buttons.

Apply 50% full-scale vacuum. The character display will alternate between +MID and CAL. Adjust for a display indication equal to 50% of full-scale vacuum using the UP and the DOWN buttons.

Absolute Reference Gauges

Apply full vacuum to the gauge. The character display will alternate between ZERO and CAL. Press the UP and DOWN buttons to obtain a display indication of zero.

Apply full-scale pressure. The character display will alternate between +SPAN and CAL. Press the UP and DOWN buttons to obtain a display indication equal to full-scale pressure.

Apply 50% of full-scale pressure. The lower display will alternate between +MID and CAL. Press the UP and DOWN buttons to obtain an indication equal to 50% of full-scale pressure.

Compound and Bipolar Gauges

In addition to the steps described above for pressure gauges, apply full-scale vacuum. The character display will alternate between -SPAN and CAL. Adjust for a display indication of actual applied vacuum using the UP and the DOWN buttons.

For bipolar and -30.00inHg/+15.00psig compound range models only, apply 50% full-scale vacuum. The character display will alternate between -MID and CAL. Adjust for a display indication equal to 50% of full-scale vacuum using the UP and the DOWN buttons.

Save Calibration

Once the adjustments are complete, press and hold the front button until the display indicates ---- then release the button to store the calibration parameters in non-volatile memory and restart the gauge.

Verify the pressure indications at 0%, 25%, 50%, 75% and 100% of full scale.

Replace the rear cover taking care not to pinch the wires between the cover and the case.

User-Defined Pass Code Configuration

Remove the rear cover to access the buttons located near the lower right and left corners of the circuit board.

View Or Change User Configuration Pass Code

With the unit off, press and hold the UP button, then press the front button.

Release all buttons when the display indicates CFG.

View Or Change User Calibration Pass Code

With the unit off, press and hold the DOWN button, then press the front button.

Release all buttons when the display indicates CAL.

Enter Access Code 1220

Before the unit enters the view or change pass code mode, the display initially indicates ____ with the first underscore blinking, and with CFGPC or CALPC on the character display.

Note: The gauge will automatically revert to normal operation if no buttons are operated for approximately 15 seconds.

To cancel and return to normal operation, press and release the front button without entering any pass code characters.

1. Use the UP and DOWN buttons to set the left-most digit to 1.
2. Press and release the front button to move to the next position. The 1 will remain, and the second position will be blinking.
3. Use the UP and DOWN buttons to select 2.
4. Press and release the front button to index to the next position. 12 will remain, and the third position will be blinking.
5. Use the UP and DOWN buttons to select 2.
6. Press and release the front button to move to the next position. 1 2 2 will remain, and the fourth position will be blinking.
7. Use the UP and DOWN buttons to select 0.
8. Press and release the front button to proceed.

Note: If an incorrect access code was entered, the gauge will return to the start of the access code entry sequence.

Once the access code has been entered correctly, the display will indicate the existing user-defined pass code with CFGPC or CALPC on the character segments.

1. Operate the UP or DOWN button to select the first character of the new pass code.
2. When the correct first character is being displayed, press and release the front button to proceed to the next pass code character.
3. Repeat above until the entire pass code is complete.
4. To exit, press and hold the front button. Release the button when the display indicates ---- to restart the gauge.
5. Replace the rear cover taking care not to pinch the power wires between the cover and the case.

Cecomp maintains a constant effort to upgrade and improve its products. Specifications are subject to change without notice. Consult factory for your specific requirements.