

- ±0.25% Test Gauge Accuracy
- 316L Stainless Steel Wetted Parts
- 1.5" or 2.0" Tri-Clamp®

- Programmable Dual Alarms and 4-20 mA Output
- Output Test Function
- Low Voltage Powered

- Food Processing
- Dairy and Breweries
- Pharmaceutical

Specifications

Ranges and Resolution

See table below. Consult factory for special engineering units. Resolution is fixed as indicated in table

Accuracy

Accuracy includes linearity, hysteresis, repeatability
 Accuracy: ±0.25% of full scale ±1 least significant digit
 Sensor hysteresis: ±0.015% FS, included in accuracy
 Sensor repeatability: ±0.01% FS, included in accuracy

Display

4 readings per second nominal display update rate
 4 digit LCD, 0.5" H and 5 character 0.25" H alphanumeric
 Red LED backlight on when gauge is on
 Alarm 1 and 2 LCD indicators and bi-color (red/green) LEDs

Controls and Functions

SEL Select and display alarm trip points
 TEST Alarm acknowledge, or toggle alarms when in test mode
 ▲ Increase alarm setpoint when in setpoint adjust mode
 ▼ Decrease alarm setpoint when in setpoint adjust mode
 Multi-level pass code protection for set-up and calibration

Calibration

User settable pass code required to enter calibration mode
 Pressure and absolute models: zero, midpoint, span
 Vacuum models: -span, -midpoint, zero
 Vacuum/pressure models: -span, zero, +midpoint, +span
 ±15 psi models: -span, -midpoint, zero, +midpoint, +span

Alarm Outputs

Dual form C (SPDT) relay contacts programmable for HI/LO, HI/HI, LO/LO, normal or reverse acting with 1% deadband, or adjustable trip/reset points for each relay, manual/auto ack. 1A/24VDC, 0.5A/115VAC, non-inductive 120 milliseconds typical response time

Retransmission Output

4-20 mA updated approximately 16 times per second
 Output drive (compliance) determined by power source
 6,553 counts over sensor range

Maximum Working Pressure

1.5": 2 X pressure range
 2.0": 2 X pressure range or 550 psi for 300 psi sensor
 Maximum pressure dependent on type of clamping device
 112.5% FS out-of-range display: |--- or |----

Housing and Materials

NEMA 4X ABS/polycarbonate case, polycarb. label, rear gasket
 Conformal coating on circuit boards for moisture resistance.

Sanitary Seal

3-A certified Tri-Clamp 316L stainless steel flush diaphragm sanitary seal with NEOBEE® M-20 fill
 Optional electropolish passivation

Environmental

Storage temperature: -40 to 203°F (-40 to 95°C)
 Operating temperature: -4 to 185°F (-20 to 85°C)
 Compensated temperature: 32 to 158°F (0 to 70°C)
 Thermal effect due to fill: Up to 1.2 psi from 0 to 70°C
 Positional effect: Up to 0.14 psi

Power

8 to 24 VAC 50/60 Hz or 9 to 32 VDC, 1.0 watt max.
 Designed for continuous operation

Weight (approximate)

1.5" gauge: 2 lbs shipping: 3 lbs
 2.0" gauge: 2.5 lbs shipping: 3.5 lbs

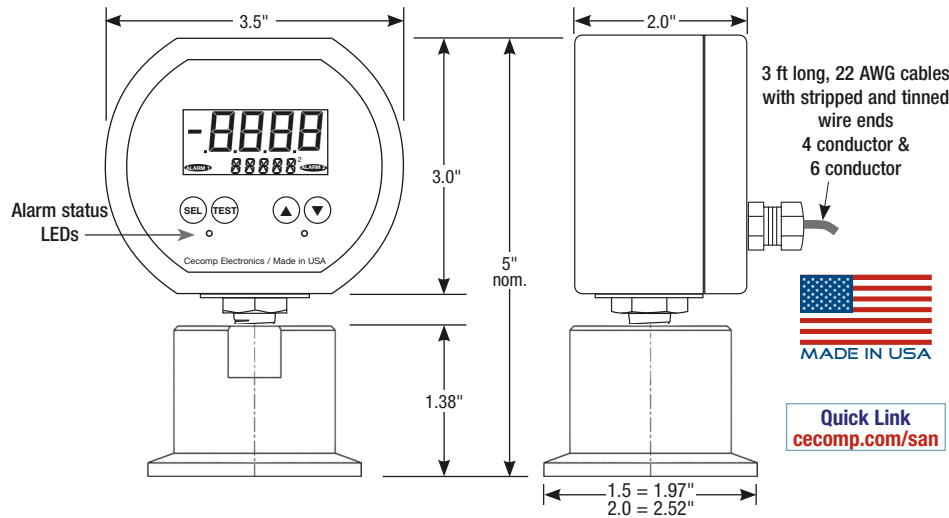

PSI	Res	inHg	Res	cmH ₂ O	Res	g/cm ²	Res	kg/cm ²	Res
15PSIA	.01	30INHGA	.01	1000CMH2OA	1	1000GCMa	1	1KGCMa	.001
15PSIVAC	.01	30INHGVAC	.01	1000CMH2OVAC	1	1000GCMVAC	1	1KGCMVAC	.001
±15PSIG	.01	±30INHGG	.01	±1000CMH2OG	1	±1000GCMG	1	±1KGCMG	.001
15PSIG	.01	30INHGG	.01	1000CMH2OG	1	1000GCMG	1	1KGCMG	.001
30PSIA	.01	60INHGA	.01	2100CMH2OA	1	2100GCMa	1	2KGCMa	.001
30PSIG	.01	60INHGG	.01	2100CMH2OG	1	2100GCMG	1	2KGCMG	.001
60PSIG	.01	120INHGG	.1	kPa	Res	mbar	Res	4KGCMG	.001
100PSIA	.1	200INHGA	.1	100KPAA	.1	1000MBARA	1	7KGCMa	.001
-15V100PSIG	.1	-30V200INHGG	.1	100KPAVAC	.1	1000MBARVAC	1	7KGCMG	.001
100PSIG	.1	200INHGG	.1	±100KPAG	.1	±1000MBARG	1	-1V7KGCMG	.01
-15V200PSIG	.1	-30V400INHGG	.1	100KPAG	.1	1000MBARG	1	14KGCMG	.01
200PSIG	.1	400INHGG	.1	200KPAA	.1	2000MBARA	1	-1V14KGCMG	.01
300PSIG	.1	600INHGG	.1	200KPAG	.1	2000MBARG	1	20KGCMG	.01
inHg/PSI	Res	mmHg	Res	400KPAG	.1	bar	Res	atm	Res
-30V15PSIG	.1	760MMHGA	.1	700KPAA	.1	1BARA	.001	1ATMA	.001
-30V100PSIG	.1	760MMHGVAC	.1	700KPAG	.1	1BARVAC	.001	1ATMVAC	.001
-30V200PSIG	.1	±760MMHGG	1	-100V700KPAG	1	±1BARG	.001	±1ATMG	.001
oz/in ²	Res	760MMHGG	.1	1400KPAG	1	1BARG	.001	1ATMG	.001
240ZINA	.1	1600MMHGA	1	-100V1400KPAG	1	2BARA	.001	2ATMA	.001
240ZINVAC	.1	1600MMHGG	1	2000KPAG	1	2BARG	.001	2ATMG	.001
±240ZING	.1	inH ₂ O	Res	ftH ₂ O	Res	4BARG	.001	4ATMG	.001
240ZING	.1	400INH2OA	.1	35FTH2O	.1	7BARA	.001	7ATMA	.001
480ZINA	.1	400INH2OVAC	.1	70FTH2O	.1	7BARG	.001	7ATMG	.001
480ZING	.1	±400INH2OG	1	140FTH2O	.1	-1V7BARG	.01	-1V7ATMG	.01
Torr	Res	400INH2OG	.1	230FTH2O	.1	14BARG	.01	14ATMG	.01
760TORRA	.1	850INH2OA	1	480FTH2O	.1	-1V14BARG	.01	-1V14ATMG	.01
760TORRVAC	.1	850INH2OG	1	700FTH2O	.1	20BARG	.01	20ATMG	.01
1600TORRA	1								

How to Specify	Size
DSGA415N range - options	1.5" Tri-Clamp
DSGA420N range - options	2.0" Tri-Clamp

Range—see table at left
 psi = PSI mmHg = MMHG MPa = MPA
 inHg = INHG torr = TORR mbar = MBAR
 oz/in² = ZIN kg/cm² = KGCM bar = BAR
 inH₂O = INH2O g/cm² = GCM cmH₂O = CMH2O
 ftH₂O = FTH2O kPa = KPA atm = ATM
 G = gauge reference pressure
 VAC = gauge reference vacuum
 A = absolute reference
 If vacuum gauge requires a minus sign, please specify.

Option—add to end of model number	Calibration certificates—order separately
-E Electropolished sanitary fitting	CD Calibration data, 5 test points, test date
	NC NIST certificate with traceability documentation, 5 test points and date

Maximum pressure dependent on type of clamping device

NEOBEE—Reg TM Stepan Specialty Products, LLC
 Tri-Clamp—Reg TM Alfa Laval Inc.

Installation Precautions

- ✓ Read these instructions before using the gauge. Configuration may be easier before installation. Contact the factory for assistance.
- ✓ These products do not contain user-serviceable parts. Contact us for repairs, service, or refurbishment.
- ✓ Gauges must be operated within specified ambient temperature ranges.
- ✓ Use a pressure or vacuum range appropriate for the application.
- ✓ Use clamp appropriate for the pressure range of the gauge.
- ✓ Remove system pressures before removing or installing gauge.
- ✓ Do not exceed relay current and voltage ratings. Use an appropriate contactor for larger loads. Inductive inrush currents may be up to 5x normal current and may require an RC snubber.
- ✓ Good design practice dictates that positive displacement liquid pumps include protection devices to prevent sensor damage from pressure spikes, acceleration head, and vacuum extremes.
- ✗ Avoid permanent sensor damage! Do not apply vacuum to non-vacuum gauges or hydraulic vacuum to any gauges.
- ✗ Avoid permanent damage! NEVER touch surface of diaphragm.
- ⚠ Gauges are not for oxygen service. Accidental rupture of sensor diaphragm may cause oil inside seal to react with oxygen.
- ✗ NEVER connect the gauge power wires directly to 115 VAC or permanent damage will result.

Types of Gauges

Gauge reference models read zero with the gauge open. Bipolar ranges read positive pressure and vacuum in the same units, and zero with the gauge port open. Absolute reference gauges read zero at full vacuum and atmospheric pressure with the gauge port open. Note that readings of atmospheric pressure vary continuously.

Electrical Connections

The 4-conductor cable with the RED and BLACK leads is for the gauge power supply.

Connect to 8-24 VAC, 50/60Hz or 9-32 VDC. When using low voltage AC power, either polarity may be used. Use the correct polarity with a DC supply.

Note that standard 24 VAC transformers with small loads may operate at voltages over the 24 VAC limit. The supply voltage, when within the stated ranges, has negligible effect on the gauge calibration.

Operation below 9 VDC or 8 VAC may cause erratic or erroneous readings or output.

When operating multiple gauges from the same power supply, refer to the mA rating in the specifications to ensure adequate power.

Route the wires away from heat sources and moving equipment.

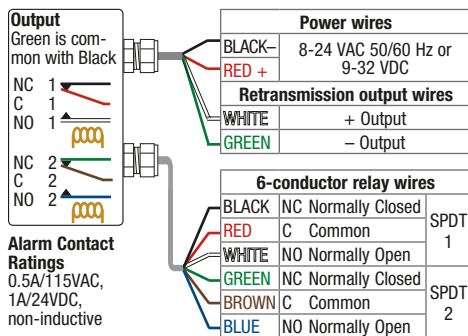

Contact Rating and Protection

The alarm contacts are rated at 1A/24VDC or 0.5A/115VAC. Using mechanical relay contacts above their rating, or with large inductive loads, will shorten their life.

For inductive loads, RC snubbers or arc suppression devices are required to protect the contacts. For large loads a higher capacity contactor is required.

No internal fusing is included in the alarm contact circuits. The alarm outputs should be externally fused by the user in applications where good design practice dictates.

Cecomp maintains a constant effort to upgrade and improve its products. Specifications are subject to change without notice. Consult factory for your specific requirements.

Power Up

The gauge is powered on whenever a supply voltage is applied. Warm-up time is negligible. The gauge may be left on at all times. All configuration information is stored in non-volatile memory.

When power is first applied, the gauge proceeds through a startup sequence. During the startup sequence, relays are de-energized, the status LEDs are off, and the retransmission output is low (0 mA).

1. The firmware version number is displayed briefly
 2. All active display segments are turned on for approx. 1 second.
 3. The full scale pressure is indicated for approx. 1 second while the engineering units and FS (full scale) are indicated for 1/2 second on the character display.
 4. The display is tested again for approximately 1 second.
- The gauge then proceeds to the normal operating mode.

The retransmission output corresponds to the applied pressure. The factory default configuration is 1% fixed deadband mode with SP1 HI and SP2 LO, normal acting relays, zero tare enabled, and no pass code required for test function.

Alarm Types

Alarms may be configured to operate in fixed deadband mode or adjustable hysteresis mode.

In the fixed deadband mode, the alarm set/reset point deadband is factory set to 1% of full-scale. Each alarm may be configured as either HI or LO with a user adjustable alarm set point for each relay.

In the adjustable hysteresis mode, two independent set and reset trip points are user adjustable for each relay. The set or reset state at power up when between trip points is user configurable.

Operation with Fixed Deadband Alarms

Each relay may be independently configured as a high or low alarm in User Set-up and operate as shown in the table below.

Normal acting, High alarm SP_H		
Pressure	< Set point - 1%FS	> Set point
Relay coil	On	Off
Alarm 1 continuity	C-NO (Red-White)	C-NC (Red-Black)
Alarm 2 continuity	C-NO (Brown-Blue)	C-NC (Brown-Green)
LED	Green	Red
Normal acting, Low alarm SP_L		
Pressure	< Set point	> Set point + 1%FS
Relay coil	Off	On
Alarm 1 continuity	C-NC (Red-Black)	C-NO (Red-White)
Alarm 2 continuity	C-NC (Brown-Green)	C-NO (Brown-Blue)
LED	Red	Green
Reverse acting, High alarm SP_H		
Pressure	< Set point - 1%FS	> Set point
Relay coil	Off	On
Alarm 1 continuity	C-NC (Red-Black)	C-NO (Red-White)
Alarm 2 continuity	C-NC (Brown-Green)	C-NO (Brown-Blue)
LED	Green	Red
Reverse acting, Low alarm SP_L		
Pressure	< Set point	> Set point + 1%FS
Relay coil	On	Off
Alarm 1 continuity	C-NO (Red-White)	C-NC (Red-Black)
Alarm 2 continuity	C-NO (Brown-Blue)	C-NC (Brown-Green)
LED	Red	Green

The relevant LCD alarm icon will indicate an alarm condition.

The relevant bi-color LED will be illuminated green for a normal condition or red for an alarm condition.

The LED will blink at a slow rate until the alarm is acknowledged unless the annunciator mode was disabled in set-up.

Alarms may be configured to be automatically acknowledged when the alarm condition clears or configured to be manually acknowledged by pressing the TEST button.

The applied pressure, the value of Trip Point 1, and the value of Trip Point 2 may be selected for display as follows:

When the applied pressure is being displayed, press and release the SEL button. The Trip Point 1 value will be displayed with TRIP1 on the lower display.

When the Trip Point 1 value is being displayed, press and release the SEL button. The upper display will indicate the Trip Point 2 value with TRIP2 on the lower display.

When the Trip Point 2 value is being displayed, press and release the SEL button. The upper display will indicate the applied pressure with engineering units on the lower display.

Operation with Adjustable Hysteresis Alarms

In the adjustable hysteresis mode, two independent set and reset trip points used for each relay. The LEDs indicate green for a RESET state and red for a SET state. Refer to the table below.

Normal (Fail-safe) acting, RESET value less than SET		
Pressure	≤ Low RESET point	≥ High SET point
Relay coil	On	Off
Alarm 1 continuity	C-NO (Red-White)	C-NC (Red-Black)
Alarm 2 continuity	C-NO (Brown-Blue)	C-NC (Brown-Green)
LED	Green	Red
Normal (Fail-safe) acting, SET value less than RESET		
Pressure	≤ Low SET point	≥ High RESET point
Relay coil	Off	On
Alarm 1 continuity	C-NC (Red-Black)	C-NO (Red-White)
Alarm 2 continuity	C-NC (Brown-Green)	C-NO (Brown-Blue)
LED	Red	Green
Reverse acting, RESET value less than SET		
Pressure	≤ Low RESET point	≥ High SET point
Relay coil	Off	On
Alarm 1 continuity	C-NC (Red-Black)	C-NO (Red-White)
Alarm 2 continuity	C-NC (Brown-Green)	C-NO (Brown-Blue)
LED	Green	Red
Reverse acting, SET value less than RESET		
Pressure	≤ Low SET point	≥ High RESET point
Relay coil	On	Off
Alarm 1 continuity	C-NO (Red-White)	C-NC (Red-Black)
Alarm 2 continuity	C-NO (Brown-Blue)	C-NC (Brown-Green)
LED	Red	Green
Power-up relay state when between SET and RESET		
Config. set to SP_L	RESET	
Config. set to SP_H	SET	

If the gauge is configured for alarms, ALARM1 and ALARM2 will be indicated when alarm conditions exist, and the associated LEDs will blink to indicate unacknowledged alarm conditions. Alarms may be configured to be automatically acknowledged when the alarm condition clears or manually acknowledged by pressing the TEST button.

The SET trip points, and the RESET trip points may be selected for display as follows.

While in the normal operating mode, press and release the SEL button. The upper display will indicate the value of set point 1 with 'SET_1' on the lower display.

While set point 1 is being displayed, press and release the SEL button. The upper display will indicate the value of reset point 1 with 'RST_1' on the lower display.

While reset point 1 is being displayed, press and release the SEL button. The upper display will indicate the value of set point 2 with 'SET_2' on the lower display.

While set point 2 is being displayed, press and release the SEL button. The upper display will indicate the value of reset point 2 with 'RST_2' on the lower display.

While the reset point 2 is being displayed, press and release the SEL button. The upper display will indicate the applied pressure and engineering units.

Retransmission Output

The retransmission output corresponds to the applied pressure, except when in zero/tare mode, test mode, or during setup. Note that analog output resolution is always over the entire sensor range and is updated approximately 16 times per second. The 4-20 mA output provides power to the current loop and output drive is determined by power source.

Output values listed below are nominal factory set ranges and may be user reconfigured. Note that -15 psi, -100 kPa, etc. is not achievable, but prevents running out of range at whatever full vacuum is reached.

Range Type	-15 psi	"0" on display	Full pressure
Gauge reference pressure	n/a	4 mA	20 mA
Gauge reference vacuum	20 mA	4 mA	n/a
Absolute reference	4 mA	4 mA	20 mA
Vacuum/pressure ranges using ±15 psi sensor	4 mA	12 mA	20 mA
Vacuum/pressure ranges using -15V100 psi	4 mA	6.4 mA	20 mA
Vacuum/pressure ranges using -15V/200 psi	4 mA	5.2 mA	20 mA

Pass Code Entry for Setup or Calibration

A pass code is required to calibrate and configure the gauge. Additional levels of security may be enabled by defining separate pass codes for calibration, user configuration, and output test and set point adjust modes. See Changing the User-Defined Pass Code at the end of this manual to change pass codes.

Functions in user configuration mode

- Restore original factory configuration
- Enable/disable zero tare function
- Fixed 1% deadband or adjustable hysteresis mode of operation
- Operation for blinking alarm LEDs
- Set point modes (high alarm/low alarm or state at power-up)
- Relay action mode (normal/reverse)
- Retransmission output upper and lower limits
- Enable/disable a pass code for output test and set point adjust

When the gauge enters a mode requiring a pass code, the display indicates `_____` with the first underscore blinking, and either TSTPC, CFGPC, CALPC on the lower display. All three pass codes are initially set to the factory default of 3510.

Note: During pass code entry the LEDs will be off and the gauge will not respond to changes in applied pressure. The relays will maintain their prior state. The gauge will automatically revert to the normal operation if no buttons are operated for approximately 15 seconds.

Use the ▲ and ▼ buttons to set the left-most digit to 3.

Press and release the SEL button to index to the next position. The 3 will remain, and the second position will be blinking.

Use the ▲ and ▼ buttons to select 5.

Press and release the SEL button to index to the next position. 3 5 will remain, and the third position will be blinking.

Use the ▲ and ▼ buttons to select 1.

Press and release the SEL button to index to the next position. 3 5 1 will remain, and the fourth position will be blinking.

Use the ▲ and ▼ buttons to select 0.

Press and release the SEL button to proceed.

If an incorrect pass code was entered, the gauge will exit to the normal operating mode. Upon successful pass code entry, follow the steps in the appropriate section of this manual.

Note: To exit a mode at any time, press and hold the SEL button until the display indicates `_____`.

Zero Tare Mode

If the gauge is not indicating zero with zero pressure applied but is within approximately 3% of full scale pressure of zero, you may tare the gauge to zero. This feature may be enabled or disabled. Absolute ranges are configured with this feature turned off.

From the normal operating mode with the gauge port open to atmosphere, press and hold both the ▲ and ▼ buttons and press the SEL button. The relay outputs and the retransmission output will hold the last value, and the visual indicators will be deactivated. Release all buttons when the display indicates `o o o o`.

The display will indicate a newly calculated zero tare value with Z OFF on the lower display. Note: If not within approximately 3% of zero, Err0 will be displayed. Press the SEL button to cancel the operation and return to normal operating mode without affecting any existing zero tare value.

To cancel and remove any existing zero tare value, press and release the ▼ button. The display will indicate zero. To restore the newly calculated zero tare value, press and release the ▲ button.

To exit the Zero/Tare mode, press and release the SEL button. The gauge will return to normal operation.

Output Test Mode

From the normal operating mode, press and hold the TEST button and press the SEL button. Release both buttons when the display indicates `_____` or `_____`.

If pass code protection is enabled, the display indicates `_____` with the left-most underscore blinking, and TSTPC.

Enter the pass code as described in the Pass Code Entry section.

While in the Test mode with no buttons pressed, the display will indicate the pressure with the engineering units blinking at a slow rate.

When the TEST button is pressed, the LED indicators and the relays will toggle to their opposite states. The display will indicate the preset test value with TEST on the lower display, and the retransmission output will correspond to the test value.

Pressing the ▲ or the ▼ button while holding the TEST button will raise or lower the test value. Note that the gauge will not respond to changes in applied pressure while the TEST button is held.

When the TEST button is released, the display, the LED indicators, and the relay outputs will correspond to the applied pressure.

Press and release the SEL button to exit the Output Test mode and return to normal operation.

Adjust Setpoint, Fixed Deadband Mode

“Set Point” is defined as the pressure value that will result in a change of state only from a normal to an alarm condition.

“Trip Point” is defined as the pressure value that will result in a change of state of alarm condition, and includes the effect of deadband when returning from an alarm to a normal condition.

Set Point 1

From the normal operating mode press the SEL button to display Trip Point 1.

Press and hold the TEST button and press the SEL button. Release both buttons when the display indicates `_____`.

If pass code protection is enabled, before the unit enters the Set Point 1 Adjust Mode, the display initially indicates `_____` with the left-most underscore blinking, and with TSTPC on the display.

Enter the pass code as described in the Pass Code Entry section.

While in the Set Point 1 Adjust mode with no buttons pressed, the display will indicate Trip Point 1 with TRIP1 blinking at a slow rate on the lower display, and the alarm indicators and the retransmission output will correspond to the applied pressure.

To adjust the Set Point 1 value, press and hold the TEST button. The display will indicate Set Point 1 with SP1 on the lower display.

Operate the ▲ and ▼ buttons to adjust Set Point 1 to the desired value. Release the TEST button to store the Set Point 1 value.

Note: The gauge will not respond to changes in applied pressure while the TEST button is pressed. The alarm relays, LEDs, LCD alarm icons, and the output will maintain their prior states until the TEST button is released.

To exit the Set Point 1 Adjust mode and return to the normal operating mode, press and release the SEL button.

Set Point 2

From the normal operating mode press the SEL button twice to display Trip Point 2.

Press and hold the TEST button and press the SEL button. Release both buttons when the display indicates `_____`.

If pass code protection is enabled, before the unit enters the Set Point 2 Adjust Mode, the display initially indicates `_____` with the left-most underscore blinking, and with TSTPC on the display.

Enter the pass code as described in the Pass Code Entry section.

While in the Set Point 2 Adjust mode with no buttons pressed, the display will indicate Trip Point 2 with TRIP2 blinking at a slow rate on the lower display, and the alarm indicators and the retransmission output will correspond to the applied pressure.

To adjust the Set Point 2 value, press and hold the TEST button. The display will indicate Set Point 2 with SP2 on the lower display.

Operate the ▲ and ▼ buttons to adjust Set Point 2 to the desired value. Release the TEST button to store the Set Point 2 value.

Note: The gauge will not respond to changes in applied pressure while the TEST button is pressed. The alarm relays, LEDs, LCD alarm icons, and the output will maintain their prior states until the TEST button is released.

To exit the Set Point 2 Adjust mode and return to normal operation, press and release the SEL button.

Adjust Trip Point, Adjustable Hysteresis Mode

From the normal operating mode press the SEL button to display the desired trip point (SET_1, RST_1, SET_2, or RST_2).

Press and hold the TEST button and press the SEL button. Release both buttons when the display indicates `_____`.

If pass code protection is enabled, before the unit enters the Set Point Adjust Mode, the display initially indicates `_____` with the left-most underscore blinking, and with TSTPC on the lower display.

Enter the pass code as described in the Pass Code Entry section.

While in the Trip Point Adjust mode with no buttons pressed, the display will indicate the trip point value with its designator (SET_1, RST_1, SET_2, or RST_2) blinking at a slow rate.

To adjust the displayed trip point value, press and hold the TEST button. The display will continue to indicate the trip point value.

Operate the ▲ and ▼ buttons to adjust the trip point to the desired value. The trip point value is stored when the TEST button is released. Note: The relays and indicators will not correspond to the applied pressure value until the TEST button is released.

To exit the Trip Point Adjust mode and return to the normal operating mode, press and release the SEL button.

User Configuration

From the normal operating mode, press and hold the TEST and the ▲ buttons.

Then press the SEL button.

Release all buttons when the display indicates CFG.

Before the gauge enters the Configuration mode, the display initially

User Configuration—cont.

indicates `_____` with the first underscore blinking, and with CFGPC on the lower display.

Enter the pass code as described in the Pass Code Entry section.

Restore Factory Configuration

The upper display will be blank, and the lower display will display either USER_ or FCTRY.

If USER_ is selected, the existing user configuration will be retained and will be accessible for modification in the following steps. To select USER_, press and release the ▼ button. The lower display will indicate USER_.

If FCTRY is selected, the existing user configuration will be replaced by the configuration as it left the factory and will be accessible for modification in the following steps. To select FCTRY, press and release the ▲ button. The lower display will indicate FCTRY.

Press and release the SEL button to move on to the next parameter.

Zero Tare Configuration

The upper display will be blank, and the lower display will indicate either ZTARE or NOZTR.

If ZTARE is selected, the user will be able to manually zero the gauge from the normal operating mode.

To select ZTARE, press and release the ▲ button. The lower display will indicate ZTARE.

If NOZTR is selected the user will be prevented from zeroing the gauge from the normal operating mode. This is default setting for absolute reference ranges.

To select NOZTR, press and release the ▼ button. The lower display will indicate NOZTR.

Press and release the SEL button to move on to the next parameter.

Setpoint Type Configuration

The lower display will either indicate DBAND or ADJ_H.

If DBAND is selected, each output relay will operate with a 1% of full-scale deadband between set and reset.

To select DBAND, press and release the ▲ button. The lower display will indicate DBAND.

If ADJ_H is selected, each output relay will have an adjustable SET point and an adjustable RESET point.

To select ADJ_H, press and release the ▼ button. The lower display will indicate ADJ_H.

Press and release the SEL button to move on to the next parameter.

Alarm Annunciator Function Selection

The lower display will indicate either A_ACK, M_ACK or NO_AN.

If A_ACK is selected, an alarm condition will be automatically acknowledged when the alarm condition clears. When an alarm condition occurs, the LED for that alarm will begin to blink red and will continue to blink red until it has been manually acknowledged or until the alarm condition clears. If an alarm is manually acknowledged, the LED will be steadily red while the alarm condition continues to exist. The LED will be steadily green whenever no alarm condition exists.

If M_ACK is selected, an alarm condition must be manually acknowledged. When an alarm condition occurs, the LED for that alarm will blink red if the alarm condition exists or green if the alarm condition no longer exists. The LED will continue to blink until it has been manually acknowledged by a pressing the TEST button. Once an alarm has been acknowledged, the LED will be steadily red while the alarm condition exists or green when the alarm no longer exists.

If NO_AN is selected, the LEDs will not blink. When an alarm condition occurs, the LED associated with that alarm will be illuminated steadily red if the alarm condition exists or green if the alarm condition no longer exists. In addition, the LCD display for ALARM1 and ALARM2 will not be displayed during alarm conditions.

Use the ▲ or ▼ buttons to cycle through the three choices. When the lower display indicates the desired annunciator action, press and release the SEL button to move on to the next parameter.

Alarm Action Selection (Fixed Deadband Configuration)

The lower display will display either SP1_L or SP1_H.

If SP1_L is selected Alarm 1 will be a low alarm. Alarm 1 will be SET when the pressure falls below Setpoint 1. Alarm 1 will be RESET when the pressure rises above Setpoint 1 plus the preset deadband. To select SP1_L, press and release the ▼ button. The lower display will indicate SP1_L.

If SP1_H is selected Alarm 1 will be a high alarm. Alarm 1 will be SET when the pressure rises above Setpoint 1. Alarm 1 will be RESET when the pressure falls below Setpoint 1 minus the preset deadband. To select SP1_H, press and release the ▲ button. The lower display will indicate SP1_H.

Press and release the SEL button to move to Alarm 2.

The upper display will be blank, and the lower display will display either SP2_L or SP2_H.

If SP2_L is selected Alarm 2 will be a low alarm. Alarm 2 will be SET

User Configuration—cont.

when the pressure falls below Setpoint 2. Alarm 2 will be RESET when the pressure rises above Setpoint 2 plus the preset deadband. To select SP2_L, press and release the ▼ button. The lower display will indicate SP2_L.

If SP2_H is selected Alarm 2 will be a high alarm. Alarm 2 will be SET when the pressure rises above Setpoint 2. Alarm 2 will be RESET when the pressure falls below Setpoint 2 minus the preset deadband. To select SP2_H, press and release the ▲ button. The lower display will indicate SP2_H.

Press and release the SEL button to move to the next parameter.

Relay Action Selection (Fixed Deadband Configuration)

The lower display will display either _NOR_ or _REV_.

If _NOR_ is selected, the output relay coils will be energized in the RESET state and de-energized in the SET state (normal action). To select _NOR_, press and release the ▼ button. The lower display will indicate _NOR_.

If _REV_ is selected, the output relay coils will be de-energized in the RESET state and energized in the SET state (reverse action). To select _REV_, press and release the ▲ button. The lower display will indicate _REV_.

Press and release the SEL button to move on to the next parameter.

Relay Power Up State (Adjustable Hysteresis Configuration)

The lower display will display either SP1_L or SP1_H.

If SP1_L is selected and the gauge is powered up while the applied pressure is between the Output 1 SET and RESET trip points, Output 1 will begin in the RESET state. To select SP1_L, press and release the ▼ button. The lower display will indicate SP1_L.

If SP1_H is selected and the gauge is powered up while the applied pressure is between the Output 1 SET and RESET trip points, Output 1 will begin in the SET state. To select SP1_H, press and release the ▲ button. The lower display will indicate SP1_H.

Press and release the SEL button to move to Relay 2.

The upper display will be blank, and the lower display will display either SP2_L or SP2_H.

If SP2_L is selected and the gauge is powered up while the applied pressure is between the Output 2 SET and RESET trip points, Output 2 will begin in the RESET state. To select SP2_L, press and release the ▼ button. The lower display will indicate SP2_L.

If SP2_H is selected and the gauge is powered up while the applied pressure is between the Output 2 SET and RESET trip points, Output 2 will begin in the SET state. To select SP2_H, press and release the ▲ button. The lower display will indicate SP2_H.

Press and release the SEL button to move on to the next parameter.

Relay Action Selection (Adjustable Hysteresis Configuration)

The upper display will be blank, and the lower display will display either _NOR1 or _REV1.

If _NOR1 is selected, the Output 1 relay coil will be energized in the RESET state and de-energized in the SET state (normal action). To select _NOR1, press and release the ▼ button. The lower display will indicate _NOR1.

If _REV1 is selected, the Output 1 relay coil will be de-energized in the RESET state and energized in the SET state (reverse action). To select _REV1, press and release the ▲ button. The lower display will indicate _REV1.

Press and release the SEL button to move on to Relay 2.

The upper display will be blank, and the lower display will display either _NOR2 or _REV2.

If _NOR2 is selected, the Output 2 relay coil will be energized in the RESET state and de-energized in the SET state (normal action). To select _NOR2, press and release the ▼ button. The lower display will indicate _NOR2.

If _REV2 is selected, the Output 2 relay coil will be de-energized in the RESET state and energized in the SET state (reverse action). To select _REV2, press and release the ▲ button. The lower display will indicate _REV2.

Press and release the SEL button to move on to the next parameter.

Analog Output Range Lower Limit Adjust

The upper display will indicate the pressure value corresponding to the minimum retransmission output, either 4 mA, 0 VDC, or -2 VDC depending on the particular gauge model. The lower display will display RNL0.

Use the ▲ and ▼ buttons to adjust the display to the desired value.

Press and release the SEL button to move on to the next parameter.

Analog Output Range Upper Limit Adjust

The upper display will indicate the pressure value corresponding to the maximum retransmission output, either 4 mA or +2 VDC depending on the particular gauge model. The lower display will display RNHI.

Use the ▲ and ▼ buttons to adjust the display to the desired value.

User Configuration—cont.

Press and release the SEL button to move to the next parameter.

Output Test and Set Point Adjust Modes Pass Code Protection

The upper display section will be blank, and the lower section will display either TSTPC or NOTPC.

To enable Output Test and Set Point Adjust Modes pass code protection, press and release the ▲ button. The lower display will indicate TSTPC.

To disable Output Test and Set Point Adjust Modes pass code protection, press and release the ▼ button. The lower display will indicate NOTPC.

Press and release the SEL button to save the configuration parameters and restart the unit. Note: The configuration parameters will not be saved if the procedure is interrupted before completion.

Calibration Preparation

Gauges are calibrated at the factory using equipment traceable to NIST. Gauges are calibrated in an upright position at normal ambient temperatures (approx. 20°C). There is no need to calibrate the gauge before putting it into service unless the process temperature and gauge position deviate from normal.

Calibration should only be performed by qualified individuals using appropriate calibration standards and procedures. Calibration intervals depend on your quality control program requirements, although many customers calibrate annually.

The calibration system must be able to generate and measure pressure/vacuum over the full range of the gauge and should be at least four times more accurate than the gauge being calibrated.

A vacuum pump able to produce a vacuum of 100 microns (0.1 torr or 100 millitorr) or lower is required for vacuum gauges. Warning: application of vacuum to non-vacuum models will result in damage to the sensor.

Allow the gauge to acclimate to the calibration temperature for at least 60 minutes. Calibrate the gauge at the same temperature as the process with the gauge oriented in the same position.

Use an accurate mA meter to calibrate the retransmission output.

Calibration

To enter the calibration mode from the normal operating mode with applied pressure being displayed, press and hold the TEST and the ▼ buttons. Then press the SEL button. Release all buttons when the display indicates CAL.

When the gauge enters the calibration mode, the display initially indicates _ _ _ _ with the first underscore blinking, and with CALPC on the lower display.

Enter the pass code as described in the Pass Code Entry section.

Upon successful calibration pass code entry, the upper display will indicate the applied pressure in the configured engineering units.

The lower display of the display will alternate between CAL and the calibration region corresponding to the applied pressure (ZERO, +MID, +SPAN, MID, or SPAN).

Note: To store the calibration parameters and exit calibration mode at any time, press and hold the SEL button until the display indicates _ _ _ _ .

Calibration of the Retransmission Output

Calibration of the retransmission output coordinates the retransmission output to the display indication, and is performed independently of applied pressure. It requires a direct physical measurement of the retransmission output.

Retransmission Output Low Value

Press and release the SEL button to step to the retransmission output low value calibration sequence, indicated by LCAL on the display.

Note: If the SEL button is held depressed for longer than 2 seconds, the display will change to indicate _ _ _ _ , and the gauge will exit the calibration mode when all buttons are released.

The upper display will indicate the pre-configured pressure corresponding to the retransmission output low value. The lower display will alternate between CAL and 4 mA.

Use the ▲ and ▼ buttons to adjust the actual retransmission output to its low value.

Retransmission Output High Value

Press and release the SEL button to step to the retransmission output high value calibration sequence, indicated by HCAL on the display.

Note: If the SEL button is held depressed for longer than 2 seconds, the display will change to indicate _ _ _ _ , and the gauge will exit the calibration mode when all buttons are released.

The upper display will indicate the pre-configured pressure corresponding to the retransmission output high value. The lower display will alternate between CAL and 20 mA.

Use the ▲ and ▼ buttons to adjust the actual loop current to its high value.

Calibration—cont.**Pressure Calibration**

The pressure calibration procedure adjusts the display indication and the retransmission output to correspond to the actual applied pressure.

If the applied pressure is not being displayed, press and release the SEL button to step to the pressure calibration sequence, indicated by CAL on the display.

Note: If the SEL button is held depressed for longer than 2 seconds, the display will change to indicate _ _ _ _ , and the gauge will exit the calibration mode when all buttons are released.

Zero calibration: Apply zero pressure. The lower display will alternate between CAL and ZERO. Use the ▲ and ▼ buttons to adjust the upper display to indicate zero.

Span calibration: Apply full-scale pressure. The lower display will alternate between CAL and +SPAN. Use the ▲ and ▼ buttons to adjust the upper display to indicate the applied pressure value.

Midpoint Non-Linearity calibration: Apply 50% full-scale positive pressure. The lower display will alternate between CAL and +MID. Use the ▲ and ▼ buttons to adjust the upper display to indicate the applied pressure value.

Negative Span calibration (bipolar and compound ranges only): Apply full-scale negative pressure. The lower display will alternate between CAL and SPAN. Use the ▲ and ▼ buttons to adjust the upper display to indicate the applied pressure value.

Negative Midpoint Non-Linearity calibration (bipolar ranges only): Apply 50% full-scale negative pressure. The lower display will alternate between CAL and MID. Use the ▲ and ▼ buttons to adjust the upper display to indicate the applied pressure value.

To store the calibration parameters and exit calibration mode, press and hold the SEL button until the display indicates _ _ _ _ .

Changing the User-Defined Pass Codes**Configuration Pass Code**

From the normal operating mode, press and hold the TEST and the ▲ buttons. Then press the SEL button. Release all buttons when the display indicates CFG.

Calibration Pass Code

From the normal operating mode, press and hold the TEST and the ▼ buttons. Then press the SEL button. Release all buttons when the display indicates CAL.

Test and Set Point Adjust Pass Code (optional)

From the normal operating mode, press and hold the TEST button. Then press the SEL button. Release all buttons when the display indicates _ _ _ _ .

Before the unit enters the view or change pass code mode, the display initially indicates _ _ _ _ with the first underscore blinking, and with CFGPC, CALPC, or TSTPC on the lower display.

Note: during pass code entry, the LEDs will be off and the gauge will not respond to changes in applied pressure. The output relays will maintain their prior states and the retransmission output will maintain its prior value. The gauge will automatically revert to normal operation if no buttons are operated for approximately 15 seconds.

Enter Factory Pass Code 1220

Use the ▲ and ▼ buttons to set the left-most digit to 1.

Press and release the SEL button to index to the next position. The 1 will remain, and the second position will be blinking.

Use the ▲ and ▼ buttons to select 2.

Press and release the SEL button to index to the next position. 1 2 will remain, and the third position will be blinking.

Use the ▲ and ▼ buttons to select 2.

Press and release the SEL button to index to the next position. 1 2 2 will remain, and the fourth position will be blinking.

Use the ▲ and ▼ buttons to select 0.

Press and release the SEL button to proceed. Note: If an incorrect pass code was entered, the gauge will exit to the normal operating mode.

Once the correct password has been entered, the display will indicate the existing pass code with CFGPC, CALPC, or TSTPC on the character segments.

Note: while in the pass code change mode, the LEDs will extinguish and the unit will not respond to changes in applied pressure and the output relays will be de-energized.

Operate the ▲ or ▼ button to select the first character of the calibration password.

When the correct first character is being displayed, press and release the SEL button to proceed to the next password character.

Repeat 1 & 2 above until the entire password is complete.

To exit the User-Defined Pass Code change mode, press and hold the SEL button. Release the button when the display indicates _ _ _ _ and the gauge restarts in the normal operating mode.